





# **Chemical anchoring systems.**

**Foil capsule systems | Injection mortar systems**

## HVU with HAS-E rod adhesive anchor

Mortar System	Benefits
 <p>Hilti HVU foil capsule</p>  <p>HAS rods HAS-E (Zinc) HAS-E-F (Gal) HAS-E-R (A4-70) HAS-HCR rods</p>	<ul style="list-style-type: none"> <li>■ suitable for non-cracked concrete C 20/25 to C 50/60</li> <li>■ high loading capacity</li> <li>■ suitable for dry and water saturated concrete</li> <li>■ large diameter applications</li> <li>■ high corrosion resistant</li> </ul>



Concrete



Small edge distance & spacing



Fire resistance



Corrosion resistance



High corrosion resistance



European Technical Approval



CE conformity



PROFIS anchor design software

### Approvals / certificates

Description	Authority / Laboratory	No. / date of issue
European technical approval <sup>a)</sup>	DIBt, Berlin	ETA-05/0255 / 2011-06-23
Fire test report	IBMB, Braunschweig	UB-3333/0891-1 / 2004-03-26
Fire test report ZTV-Tunnel	IBMB, Braunschweig	UB 3333/0891-2 / 2003-08-12
Assessment report (fire)	warringtonfire	WF 166402 / 2007-10-26

a) All data given in this section according ETA-05/0255, issue 2011-06-23

### Service temperature range

Hilti HVU adhesive may be applied in the temperature ranges given below. An elevated base material temperature may lead to a reduction of the design bond resistance.

Temperature range	Base material temperature	Maximum long term base material temperature	Maximum short term base material temperature
Temperature range I	-40 °C to +40 °C	+24 °C	+40 °C
Temperature range II	-40 °C to +80 °C	+50 °C	+80 °C
Temperature range III	-40 °C to +120 °C	+72 °C	+120 °C

#### Max short term base material temperature

Short-term elevated base material temperatures are those that occur over brief intervals, e.g. as a result of diurnal cycling.

#### Max long term base material temperature

Long-term elevated base material temperatures are roughly constant over significant periods of time.

## Design process for typical anchor layouts

The design values in the tables are obtained from the design method according to ETAG 001, Annex C and Hilti simplified design method. Design resistance according to data given in ETA-05/0255, issue 2011-06-23.

- Influence of concrete strength
- Influence of edge distance
- Influence of spacing

The design method is based on the following simplification:

- No different loads are acting on individual anchors (no eccentricity)

The values are valid for the anchor configuration.

For more complex fastening applications please use the anchor design software PROFIS Anchor.

### STEP 1: TENSION LOADING

The design tensile resistance  $N_{Rd}$  is the lower of:

- Combined pull-out and concrete cone resistance

$$N_{Rd,p} = f_{B,p} \cdot N^*_{Rd,p}$$

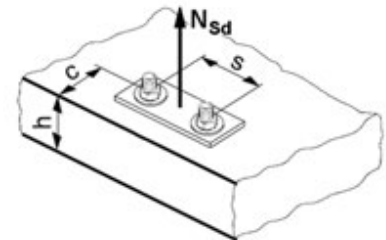

$N^*_{Rd,p}$  is obtained from the relevant design tables

$f_{B,p}$  influence of concrete strength on combined pull-out and concrete cone resistance

Concrete Strengths $f'_{c,cyl}$ (MPa)	20	25	32	40	50
$f_{B,p}$	0.95	0.97	1.00	1.02	1.04

- Concrete cone or concrete splitting resistance

$$N_{Rd,c} = f_B \cdot N^*_{Rd,c}$$

$N^*_{Rd,c}$  is obtained from the relevant design tables

$f_B$  influence of concrete strength on concrete cone resistance

Concrete Strengths $f'_{c,cyl}$ (MPa)	20	25	32	40	50
$f_B$	0.79	0.87	1.00	1.11	1.22

- Design steel resistance (tension)  $N_{Rd,s}$

Anchor size		M8	M10	M12	M16	M20	M24	
$N_{Rd,s}$	HAS – E 5.8	[kN]	11.3	17.3	25.3	48.0	74.7	106.7
	HAS-E-R	[kN]	12.3	19.8	28.3	54.0	84.0	119.8

$$N_{Rd} = \min \{ N_{Rd,p}, N_{Rd,c}, N_{Rd,s} \}$$

**CHECK  $N_{Rd} \geq N_{Sd}$**

## STEP 2: SHEAR LOADING

The design shear resistance  $V_{Rd}$  is the lower of:

■ **Design Concrete Edge Resistance**

$$V_{Rd,c} = f_B \cdot V^*_{Rd,c}$$

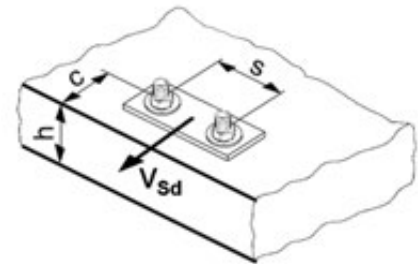

$V^*_{Rd,c}$  is obtained from the relevant design table

**$f_B$  influence of concrete strength**

Concrete Strengths $f'_{c,cyl}$ (MPa)	20	25	32	40	50
$f_B$	0.79	0.87	1.00	1.11	1.22

**Shear load acting parallel to edge:**

These tables are for a single free edge only

**2 anchors:**

For shear loads acting parallel to this edge, the concrete resistance  $V^*_{Rd,c}$  can be multiplied by the factor = 2.5

**4 anchors:**

For shear loads acting parallel to the edge - the anchor row closest to the edge is checked to resist half the total design load.

To obtain the concrete resistance use the corresponding 2 anchor configuration  $V^*_{Rd,c}$  and multiply by the factor = 2.5

■ **Design steel resistance (shear):  $V_{Rd,s}$**

Anchor size		M8	M10	M12	M16	M20	M24	
$V_{Rd,s}$	HAS - E 5.8	[kN]	6.8	10.4	15.2	28.8	44.8	64.0
	HAS-E-R	[kN]	7.7	11.5	17.3	32.7	50.6	71.8

$$V_{Rd} = \min \{ V_{Rd,c}, V_{Rd,s} \}$$

**CHECK  $V_{Rd} \geq V_{Sd}$**

## STEP 3: COMBINED TENSION AND SHEAR LOADING

The following equations must be satisfied:

$$N_{Sd}/N_{Rd} + V_{Sd}/V_{Rd} \leq 1.2$$

and

$$N_{Sd}/N_{Rd} \leq 1, V_{Sd}/V_{Rd} \leq 1$$

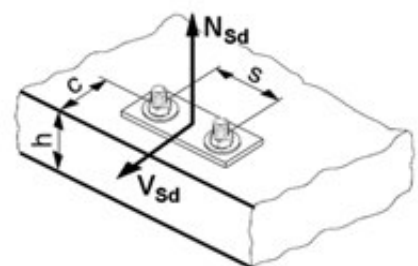



## Precalculated table values – design resistance values

### General:

The following tables provide the total ultimate limit state design resistance for the configurations. All tables are based upon:

- correct setting (See setting instruction)
- non-cracked concrete –  $f_{c,cyl} = 32 \text{ MPa}$
- temperature range I (see service temperature range)
- base material thickness, as specified in the table
- One typical embedment depth, as specified in the tables

## Basic loading data (for a single anchor) – no edge distance and spacing influence

### Embedment depth and base material thickness for the basic loading data

Anchor size	M8	M10	M12	M16	M20	M24
Typical embedment depth $h_{ef}$ [mm]	80	90	110	125	170	210
Base material thickness $h$ [mm]	110	120	140	170	220	270

## Design resistance [kN] – uncracked concrete, 32 Mpa

Anchor size		M8	M10	M12	M16	M20	M24
Non-cracked concrete							
Tensile	Pull-out $N_{Rd,p}^*$	17.9	25.0	35.8	42.9	82.3	100.2
	Concrete $N_{Rd,c}^*$	30.5	36.4	49.1	59.5	94.4	129.6
Shear	$V_{Rd,s}$	Steel governed refer $V_{Rd,s}$ table					

## Basic loading data (for a single anchor) – with minimum edge distance

### Design resistance [kN] - uncracked concrete, 32 Mpa

Anchor size		M8	M10	M12	M16	M20	M24
Min. edge distance $c_{min}$ [mm]		40	45	55	65	90	120
Min Base thickness $h_{min}$ [mm]		110	120	140	170	220	270
<b>Tensile <math>N_{Rd}</math></b>							
	Pull-out $N_{Rd,p}^*$ [kN]	10.1	13.6	19.7	23.6	46.0	61.3
	Concrete $N_{Rd,c}^*$ [kN]	14.5	17.1	23.0	28.5	44.9	63.0
<b>Shear <math>V_{Rd}</math></b>							
	Shear $V_{Rd,c}$ (without lever arm)	4.7	5.9	8.3	11.2	19.1	29.8

## Two anchors

**Table 1:** One edge influence

Design Data:  $f_{c,cyl}=32$  MPa

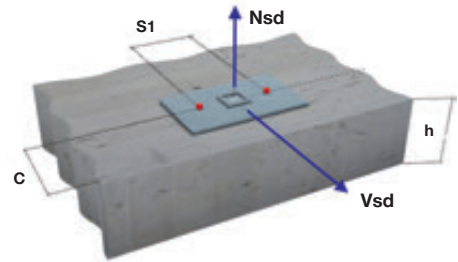

Anchor size	M8	M10	M12	M16	M20	M24
Typical embedment depth $h_{ef}$ [mm]	80	90	110	125	170	210
Base material thickness $h$ [mm]	110	120	140	170	220	270

ANCHOR <b>M8</b>	Edge C (mm)														
	40			80			100			150			170		
	tension		shear	tension		shear	tension		shear	tension		shear	tension		shear
spacing $s_1$ (mm)	$N^*_{Rd,p}$	$N^*_{Rd,c}$	$V^*_{Rd,c}$	$N^*_{Rd,p}$	$N^*_{Rd,c}$	$V^*_{Rd,c}$	$N^*_{Rd,p}$	$N^*_{Rd,c}$	$V^*_{Rd,c}$	$N^*_{Rd,p}$	$N^*_{Rd,c}$	$V^*_{Rd,c}$	$N^*_{Rd,p}$	$N^*_{Rd,c}$	$V^*_{Rd,c}$
40	13.6	16.2	6.3	19.9	21.1	13.1	23.5	23.7	15.4	24.1	30.9	21.0	24.1	34.1	23.2
80	15.3	17.9	7.9	22.3	23.3	15.0	26.3	26.2	17.2	27.0	34.2	22.7	27.0	37.6	24.9
100	16.1	18.8	8.7	23.5	24.4	15.9	27.7	27.4	18.1	28.4	35.8	23.6	28.4	39.4	25.8
120	16.9	19.6	9.4	24.7	25.5	16.9	29.1	28.7	19.0	29.8	37.4	24.5	29.8	41.2	26.6
150	18.1	20.9	9.4	26.5	27.2	18.3	31.2	30.6	20.4	31.9	39.9	25.7	31.9	43.9	27.9
200	20.0	23.0	9.4	29.3	29.9	20.6	34.5	33.7	22.7	35.4	43.9	27.9	35.4	48.4	30.0

ANCHOR <b>M10</b>	Edge C (mm)														
	45			80			100			150			200		
	tension		shear	tension		shear	tension		shear	tension		shear	tension		shear
spacing $s_1$ (mm)	$N^*_{Rd,p}$	$N^*_{Rd,c}$	$V^*_{Rd,c}$	$N^*_{Rd,p}$	$N^*_{Rd,c}$	$V^*_{Rd,c}$	$N^*_{Rd,p}$	$N^*_{Rd,c}$	$V^*_{Rd,c}$	$N^*_{Rd,p}$	$N^*_{Rd,c}$	$V^*_{Rd,c}$	$N^*_{Rd,p}$	$N^*_{Rd,c}$	$V^*_{Rd,c}$
45	17.6	19.1	7.9	23.3	23.3	14.8	26.9	25.9	17.2	32.4	33.0	23.2	32.4	40.5	29.1
100	20.2	21.5	10.3	26.7	26.3	17.6	30.8	29.2	19.9	37.1	37.1	25.8	37.1	45.5	31.6
150	22.4	23.6	11.8	29.7	28.9	20.2	34.3	32.1	22.4	41.3	40.9	28.1	41.3	50.1	33.8
200	24.7	25.8	11.8	32.7	31.5	22.8	37.7	35.1	24.9	45.4	45.6	30.5	45.4	54.7	36.0
250	26.9	28.0	11.8	35.6	34.2	24.9	41.1	38.0	27.4	49.5	48.3	32.8	49.5	59.3	38.3
300	27.2	30.1	11.8	36.0	36.8	24.9	41.6	41.0	29.9	50.1	52.1	35.1	50.1	63.9	40.6

ANCHOR <b>M12</b>	Edge C (mm)														
	55			80			100			150			200		
	tension		shear	tension		shear	tension		shear	tension		shear	tension		shear
spacing $s_1$ (mm)	$N^*_{Rd,p}$	$N^*_{Rd,c}$	$V^*_{Rd,c}$	$N^*_{Rd,p}$	$N^*_{Rd,c}$	$V^*_{Rd,c}$	$N^*_{Rd,p}$	$N^*_{Rd,c}$	$V^*_{Rd,c}$	$N^*_{Rd,p}$	$N^*_{Rd,c}$	$V^*_{Rd,c}$	$N^*_{Rd,p}$	$N^*_{Rd,c}$	$V^*_{Rd,c}$
55	25.3	25.5	11.1	30.1	28.7	16.4	34.2	31.4	20.4	45.5	38.5	27.0	46.0	46.3	33.5
100	27.9	27.6	13.3	33.2	31.1	18.9	37.7	34.0	23.0	50.1	41.7	29.4	50.7	50.1	35.8
150	30.7	29.9	15.8	36.6	33.7	21.7	41.5	36.8	25.9	55.2	45.2	32.1	55.9	54.3	38.4
200	33.6	32.2	16.6	39.9	36.3	24.5	45.4	39.6	28.8	60.3	48.7	34.8	61.0	58.5	41.0
250	36.4	34.6	16.6	43.3	38.9	26.7	49.1	42.5	31.6	65.4	52.1	37.5	66.1	62.7	43.5
300	39.1	36.9	16.6	46.5	41.5	26.7	52.9	45.3	34.5	70.3	55.6	40.2	71.1	66.9	46.1

ANCHOR <b>M16</b>	Edge C (mm)														
	65			100			150			200			250		
	tension		shear	tension		shear	tension		shear	tension		shear	tension		shear
spacing s1 (mm)	N*Rd,p	N*Rd,c	V*Rrd,c	N*Rd,p	N*Rd,c	V*Rrd,c	N*Rd,p	N*Rd,c	V*Rrd,c	N*Rd,p	N*Rd,c	V*Rrd,c	N*Rd,p	N*Rd,c	V*Rrd,c
65	30.4	32.0	15.0	37.2	37.1	23.5	48.0	45.1	32.4	55.3	53.7	39.8	55.3	63.0	47.0
100	32.4	33.8	17.0	39.7	39.3	25.7	51.2	47.7	34.6	58.9	56.8	41.9	58.9	66.6	49.1
150	35.3	36.5	19.8	43.2	42.4	28.9	55.8	51.4	37.8	64.2	61.2	44.9	64.2	71.9	52.0
200	38.1	39.2	22.4	46.7	45.4	32.1	60.3	55.1	40.9	69.4	65.7	47.9	69.4	77.1	54.8
250	41.0	41.8	22.4	50.2	48.5	35.3	64.8	58.9	44.1	74.6	70.1	50.9	74.6	82.3	57.7
300	43.8	44.5	22.4	53.6	51.6	38.6	69.2	62.6	47.2	79.7	74.6	53.9	79.7	87.5	60.6

ANCHOR <b>M20</b>	Edge C (mm)														
	90			150			200			250			300		
	tension		shear	tension		shear	tension		shear	tension		shear	tension		shear
spacing s1 (mm)	N*Rd,p	N*Rd,c	V*Rrd,c	N*Rd,p	N*Rd,c	V*Rrd,c	N*Rd,p	N*Rd,c	V*Rrd,c	N*Rd,p	N*Rd,c	V*Rrd,c	N*Rd,p	N*Rd,c	V*Rrd,c
90	56.9	50.1	25.4	73.5	59.9	42.8	88.8	68.6	51.4	101.9	77.9	59.9	101.9	87.7	68.3
150	62.4	53.6	29.7	80.5	64.1	47.5	97.3	73.4	55.8	111.6	83.4	64.2	111.6	93.9	72.5
200	66.9	56.5	33.2	86.4	67.6	51.5	104.3	77.4	59.6	119.7	87.9	67.7	119.7	99.0	75.9
250	71.4	59.5	36.7	92.2	71.1	55.4	111.4	81.4	63.6	127.8	92.4	71.3	127.8	104.1	79.4
300	75.9	62.4	38.1	98.1	74.6	59.4	118.4	85.4	67.0	135.9	97.0	74.9	135.9	109.2	82.8
350	80.4	65.3	38.1	103.9	78.0	63.4	125.4	89.4	70.7	143.9	101.5	78.4	143.9	114.3	86.3

ANCHOR <b>M24</b>	Edge C (mm)														
	120			150			200			250			350		
	tension		shear	tension		shear	tension		shear	tension		shear	tension		shear
spacing s1 (mm)	N*Rd,p	N*Rd,c	V*Rrd,c	N*Rd,p	N*Rd,c	V*Rrd,c	N*Rd,p	N*Rd,c	V*Rrd,c	N*Rd,p	N*Rd,c	V*Rrd,c	N*Rd,p	N*Rd,c	V*Rrd,c
120	80.5	70.9	39.8	90.5	76.3	49.7	108.2	85.7	64.0	127.4	95.6	73.6	131.6	116.8	92.6
150	83.7	72.9	42.3	94.1	78.5	52.3	112.5	88.1	66.7	132.4	98.3	76.2	136.8	120.1	95.0
200	89.0	76.3	46.4	100.0	82.1	56.7	119.6	92.2	71.1	140.8	102.8	80.4	145.5	125.6	98.9
250	94.4	79.6	50.6	106.0	85.6	61.0	126.7	96.2	75.6	149.2	107.2	84.6	154.2	131.0	102.9
300	99.6	82.9	54.7	111.9	89.2	65.4	133.8	100.2	80.0	157.5	111.7	88.9	162.8	136.5	106.9
350	104.9	86.2	58.9	117.8	92.8	69.7	140.9	104.2	84.5	165.8	116.2	93.1	171.4	142.0	110.8

## Four anchors

**Table 2:** One edge influence

Design Data:  $f_{c,cyl}=32$  MPa

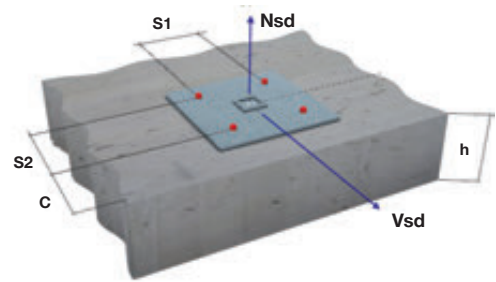

Anchor size	M8	M10	M12	M16	M20	M24
Typical embedment depth $h_{ef}$ [mm]	80	90	110	125	170	210
Base material thickness $h$ [mm]	110	120	140	170	220	270

ANCHOR <b>M8</b>	Edge C (mm)														
	40			80			100			150			200		
	tension		shear	tension		shear	tension		shear	tension		shear	tension		shear
spacing $s1 = s2$ (mm)	$N^*_{Rd,p}$	$N^*_{Rd,c}$	$V^*_{Rd,c}$	$N^*_{Rd,p}$	$N^*_{Rd,c}$	$V^*_{Rd,c}$	$N^*_{Rd,p}$	$N^*_{Rd,c}$	$V^*_{Rd,c}$	$N^*_{Rd,p}$	$N^*_{Rd,c}$	$V^*_{Rd,c}$	$N^*_{Rd,p}$	$N^*_{Rd,c}$	$V^*_{Rd,c}$
40	20.2	19.3	12.6	28.2	24.4	17.7	32.6	27.2	19.9	33.3	34.8	25.4	33.3	38.1	30.9
80	26.5	24.7	15.7	35.7	30.7	23.8	40.8	34.0	26.0	41.6	42.7	31.4	41.6	46.5	36.8
100	29.8	27.7	17.3	39.7	34.1	26.9	45.2	37.6	29.0	46.0	47.0	34.4	46.0	51.0	39.8
120	33.3	30.8	18.9	43.9	37.7	29.9	49.7	41.4	32.0	50.6	51.5	37.4	50.6	55.8	42.7
150	38.8	35.8	18.9	50.4	43.5	34.3	56.7	47.5	36.4	57.7	58.6	41.8	57.7	63.3	47.0
200	48.3	45.0	18.9	61.6	53.9	41.2	68.9	58.6	43.7	70.0	71.4	49.0	70.0	76.9	54.2

ANCHOR <b>M10</b>	Edge C (mm)														
	45			80			100			150			200		
	tension		shear	tension		shear	tension		shear	tension		shear	tension		shear
spacing $s1 = s2$ (mm)	$N^*_{Rd,p}$	$N^*_{Rd,c}$	$V^*_{Rd,c}$	$N^*_{Rd,p}$	$N^*_{Rd,c}$	$V^*_{Rd,c}$	$N^*_{Rd,p}$	$N^*_{Rd,c}$	$V^*_{Rd,c}$	$N^*_{Rd,p}$	$N^*_{Rd,c}$	$V^*_{Rd,c}$	$N^*_{Rd,p}$	$N^*_{Rd,c}$	$V^*_{Rd,c}$
45	17.3	22.6	15.7	32.1	27.1	20.2	36.5	29.9	22.6	43.1	37.3	28.5	43.1	45.1	34.3
100	34.6	30.3	20.6	42.9	35.7	29.2	48.1	39.0	31.6	56.0	47.8	37.3	56.0	57.0	43.0
150	44.2	38.2	23.6	54.0	44.5	37.2	60.0	48.3	39.5	69.1	58.5	45.1	69.1	69.1	50.8
200	54.7	47.0	23.6	65.9	54.2	45.0	72.8	58.6	47.3	83.1	70.2	52.9	83.1	82.4	58.4
250	65.9	56.7	23.6	78.6	64.9	49.8	86.4	69.9	54.8	98.0	83.1	60.5	98.0	96.8	66.0
300	67.5	67.3	23.6	80.4	76.6	49.8	88.3	82.2	59.8	100.2	97.0	68.1	100.2	112.3	73.6

ANCHOR <b>M12</b>	Edge C (mm)														
	55			80			100			150			200		
	tension		shear	tension		shear	tension		shear	tension		shear	t	n	shear
spacing $s1 = s2$ (mm)	$N^*_{Rd,p}$	$N^*_{Rd,c}$	$V^*_{Rd,c}$	$N^*_{Rd,p}$	$N^*_{Rd,c}$	$V^*_{Rd,c}$	$N^*_{Rd,p}$	$N^*_{Rd,c}$	$V^*_{Rd,c}$	$N^*_{Rd,p}$	$N^*_{Rd,c}$	$V^*_{Rd,c}$	$N^*_{Rd,p}$	$N^*_{Rd,c}$	$V^*_{Rd,c}$
55	35.7	30.2	22.1	41.5	33.5	25.1	46.5	36.4	27.7	60.0	43.9	34.2	60.6	52.0	40.6
100	45.0	36.7	26.6	51.6	40.5	33.3	57.2	43.7	35.8	72.5	52.1	42.2	73.2	61.3	48.5
150	56.3	44.7	31.7	63.9	49.0	43.4	70.4	52.6	44.7	87.8	62.2	50.9	88.6	72.5	57.1
200	68.7	53.5	33.2	77.3	58.3	49.0	84.6	62.4	53.3	104.3	73.1	59.5	105.2	84.6	65.6
250	81.9	63.0	33.2	91.7	68.4	53.5	99.8	73.0	63.3	121.8	84.9	68.0	122.8	97.7	74.0
300	96.0	73.3	33.2	106.8	79.3	53.5	115.9	84.3	69.0	140.3	97.5	76.3	141.4	111.6	82.4



**Shear design:** The concrete edge resistance value in this table uses all 4 anchors in shear. You will need to ensure the gap between anchor and the plate is filled. This can be achieved using the Hilti Dynamic Set. (Refer page 41 for further details)

The concrete edge resistance values have been obtained by taking the lesser of:

1. First row resistance multiplied by number of rows and
2. The concrete edge resistance of the furthest row.

ANCHOR <b>M16</b>	Edge C (mm)														
	65			100			150			200			250		
	tension		shear	tension		shear	tension		shear	tension		shear	tension		shear
spacing s1= s2 (mm)	N*Rd,p	N*Rd,c	V*Rrd,c	N*Rd,p	N*Rd,c	V*Rrd,c	N*Rd,p	N*Rd,c	V*Rrd,c	N*Rd,p	N*Rd,c	V*Rrd,c	N*Rd,p	N*Rd,c	V*Rrd,c
65	43.0	38.2	29.5	51.2	43.7	34.6	64.3	52.0	42.0	73.0	61.1	49.2	73.0	70.9	56.4
100	50.1	44.0	33.9	59.1	49.9	41.9	73.3	59.0	49.1	82.7	68.9	56.2	82.7	79.5	63.2
150	61.1	52.9	39.7	71.3	59.6	52.0	87.2	69.8	59.0	97.7	80.9	66.0	97.7	92.6	72.9
200	73.0	62.6	44.9	84.4	70.1	61.8	102.1	81.5	68.7	113.8	93.7	75.6	113.8	106.8	82.5
250	85.7	73.1	44.9	98.4	81.4	70.7	118.0	94.0	78.4	130.8	107.5	85.2	130.8	122.0	92.0
300	99.2	84.4	44.9	113.1	93.5	77.1	134.7	107.4	87.9	148.8	122.3	94.6	148.8	138.1	101.4

ANCHOR <b>M20</b>	Edge C (mm)														
	90			150			200			250			300		
	tension		shear	tension		shear	tension		shear	tension		shear	tension		shear
spacing s1= s2 (mm)	N*Rd,p	N*Rd,c	V*Rrd,c	N*Rd,p	N*Rd,c	V*Rrd,c	N*Rd,p	N*Rd,c	V*Rrd,c	N*Rd,p	N*Rd,c	V*Rrd,c	N*Rd,p	N*Rd,c	V*Rrd,c
90	76.6	59.6	47.9	95.7	70.0	58.2	113.1	79.2	66.6	127.9	89.0	75.0	127.9	99.3	83.3
150	94.8	70.6	59.3	116.6	82.1	72.5	136.4	92.3	80.7	153.1	103.1	88.9	153.1	114.4	97.0
200	111.4	80.4	66.4	135.5	92.9	84.1	157.4	103.9	92.2	175.8	115.6	100.3	175.8	127.9	108.3
250	129.2	90.8	73.5	155.8	104.3	95.5	179.8	116.3	103.5	200.0	128.9	111.5	200.0	142.1	119.5
300	148.2	101.9	76.3	177.3	116.4	106.7	203.6	129.3	114.7	225.7	142.8	122.6	225.7	157.1	130.5
350	168.4	113.5	76.3	200.2	129.2	117.9	228.8	143.0	125.8	252.8	157.5	133.6	252.8	172.8	141.5

ANCHOR <b>M24</b>	Edge C (mm)														
	120			150			200			250			350		
	tension		shear	tension		shear	tension		shear	tension		shear	tension		shear
spacing s1= s2 (mm)	N*Rd,p	N*Rd,c	V*Rrd,c	N*Rd,p	N*Rd,c	V*Rrd,c	N*Rd,p	N*Rd,c	V*Rrd,c	N*Rd,p	N*Rd,c	V*Rrd,c	N*Rd,p	N*Rd,c	V*Rrd,c
120	115.5	85.3	71.7	127.5	91.0	77.4	148.7	101.0	86.9	171.5	111.5	96.4	176.5	133.8	115.0
150	126.2	91.3	79.9	138.8	97.3	85.6	161.1	107.8	95.0	185.1	118.6	104.3	190.4	142.0	122.8
200	144.9	101.9	92.8	158.7	108.3	98.9	183.0	119.5	108.2	209.1	131.1	117.4	214.8	156.0	135.6
250	164.9	113.0	101.1	179.8	119.9	112.0	206.2	131.8	121.1	234.4	144.2	130.2	240.6	170.8	148.3
300	185.9	124.7	109.4	202.1	132.0	124.9	230.6	144.7	133.9	260.9	158.0	142.9	267.6	186.2	160.8
350	207.9	137.0	117.7	225.4	144.8	139.5	256.0	158.2	146.6	288.6	172.3	155.5	295.8	202.2	173.3

## Materials

### Mechanical properties of HAS

			Data according ETA-05/0255, issue 2011-06-23						
Anchor size			M8	M10	M12	M16	M20	M24	M30
Nominal tensile strength $f_{uk}$	HAS-(E) 5.8 [N/mm <sup>2</sup> ]		500	500	500	500	500	500	-
	HAS-(E)(F) 8.8 [N/mm <sup>2</sup> ]		800	800	800	800	800	800	800
	HAS -(E)R [N/mm <sup>2</sup> ]		700	700	700	700	700	700	500
	HAS -(E)HCR [N/mm <sup>2</sup> ]		800	800	800	800	800	700	-
Yield strength $f_{yk}$	HAS-(E) [N/mm <sup>2</sup> ]		400	400	400	400	400	400	-
	HAS-(E)(F) 8.8 [N/mm <sup>2</sup> ]		640	640	640	640	640	640	640
	HAS -(E)R [N/mm <sup>2</sup> ]		450	450	450	450	450	450	210
	HAS -(E)HCR [N/mm <sup>2</sup> ]		640	640	640	640	640	400	-
Stressed cross-section $A_s$	HAS	[mm <sup>2</sup> ]	32.8	52.3	76.2	144	225	324	519
Section modulus Z	HAS	[mm <sup>3</sup> ]	27.0	54.1	93.8	244	474	809	1706
<b>Steel failure with lever arm</b>			<b>M8</b>	<b>M10</b>	<b>M12</b>	<b>M16</b>	<b>M20</b>	<b>M24</b>	<b>M30</b>
Design bending moment $M_{Rd,s}$	HAS-E-5.8 [Nm]		13	26	45	118	227	389	NA
	HAS-E-8.8 [Nm]		NA	NA	NA	NA	NA	NA	1310
	HAS-E-R [Nm]		15	29	51	131	255	436	430
	HAS-E-HCR [Nm]		21	42	72	187	364	389	819

### Material quality

Part	Material
Threaded rod HAS-(E) M8-M24 HAS-(E) M27+M30	Strength class 5.8, EN ISO 898-1, $A_s > 8\%$ ductile steel galvanized $\geq 5 \mu\text{m}$ , EN ISO 4042 (F) hot dipped galvanized $\geq 45 \mu\text{m}$ , EN ISO 10684
Threaded rod HAS-(E)(F) M8-M30 HAS-(E) M27+M30	Strength class 8.8, EN ISO 898-1, $A_s > 8\%$ ductile steel galvanized $\geq 5 \mu\text{m}$ , EN ISO 4042 (F) hot dipped galvanized $\geq 45 \mu\text{m}$ , EN ISO 10684
Threaded rod HAS-(E)R	Stainless steel grade A4, $A_s > 8\%$ ductile strength class 70 for $\leq M24$ and class 50 for M27 to M30, EN ISO 3506-1, EN 10088: 1.4401; 1.4404; 1.4578; 1.4571; 1.4439; 1.4362
Threaded rod HAS-(E)HCR	High corrosion resistant steel, EN ISO 3506-1, EN 10088: 1.4529; 1.4565 strength $\leq M20$ : $R_m = 800 \text{ N/mm}^2$ , $R_{p0.2} = 640 \text{ N/mm}^2$ , $A_s > 8\%$ ductile M24: $R_m = 700 \text{ N/mm}^2$ , $R_{p0.2} = 400 \text{ N/mm}^2$ , $A_s > 8\%$ ductile
Washer ISO 7089	Steel galvanized, EN ISO 4042; hot dipped galvanized, EN ISO 10684
	Stainless steel, EN 10088: 1.4401
	High corrosion resistant steel, EN 10088: 1.4529; 1.4565
Nut EN ISO 4032	Strength class 8, ISO 898-2 steel galvanized $\geq 5 \mu\text{m}$ , EN ISO 4042 hot dipped galvanized $\geq 45 \mu\text{m}$ , EN ISO 10684
	Strength class 70, EN ISO 3506-2, stainless steel grade A4, EN 10088: 1.4401; 1.4404; 1.4578; 1.4571; 1.4439; 1.4362
	Strength class 70, EN ISO 3506-2, high corrosion resistant steel, EN 10088: 1.4529; 1.4565

### Anchor dimensions

Anchor size	M8	M10	M12	M16	M20	M24	M30 <sup>a)</sup>
Anchor rod HAS-E, HAS-R, HAS-ER HAS-HCR	M8x80	M10x90	M12x110	M16x125	M20x170	M24x210	M30x270
Anchor embedment depth [mm]	80	90	110	125	170	210	270

a) M30 design please use anchor design software PROFIS anchor.

### Setting

#### Installation equipment

Anchor size	M8	M10	M12	M16	M20	M24	M30
Rotary hammer	TE 2 - TE 30				TE 40 - TE 70		
Other tools	compressed air gun or blow out pump, set of cleaning brushes, dispenser						

### Setting instructions

#### Dry and water-saturated concrete, hammer drilling

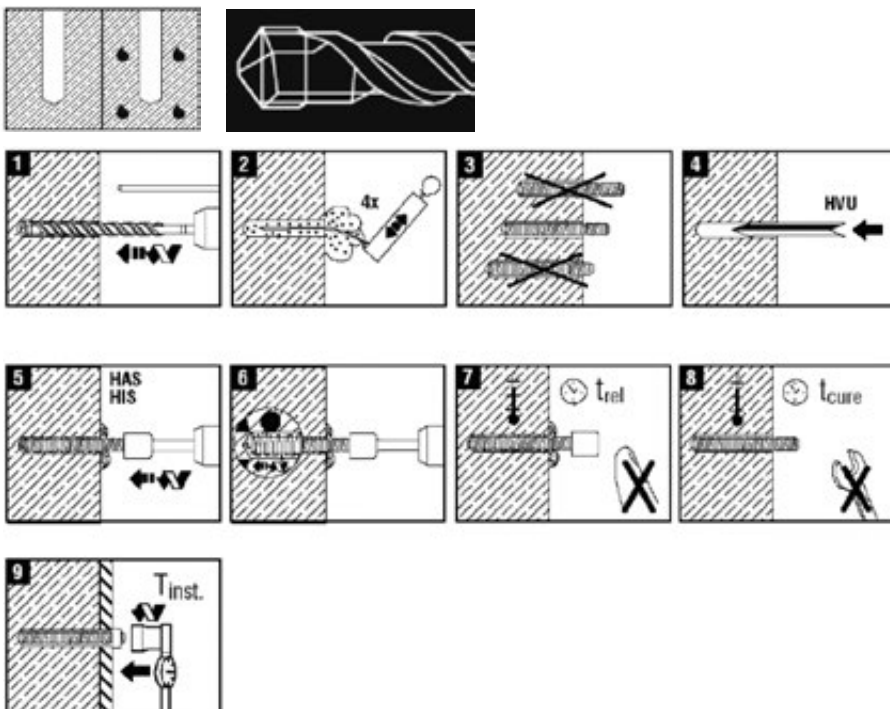

For detailed information on installation see instruction for use given with the package of the product.

## Curing time for general conditions



Data according ETA-05/0255, issue 2011-06-23	
Temperature of the base material	Curing time before anchor can be fully loaded $t_{\text{cure}}$
20 °C to 40 °C	20 min
10 °C to 19 °C	30 min
0 °C to 9 °C	1 h
-5 °C to - 1 °C	5 h

## Setting details

			Data according ETA-05/0255, issue 2011-06-23						
Anchor size			M8	M10	M12	M16	M20	M24	M30
Nominal diameter of drill bit	$d_0$	[mm]	10	12	14	18	24	28	35
Effective anchorage and drill hole depth	$h_{\text{ef,min}}$	[mm]	80	90	110	125	170	210	270
Max. fixture thickness	$t_{\text{fix,max}}$	[mm]	14	21	28	38	48	54	70
Diameter of clearance hole in the fixture	$d_f$	[mm]	9	12	14	18	22	26	33
Minimum spacing	$s_{\text{min}}$	[mm]	40	45	55	65	90	120	135
Minimum edge distance	$c_{\text{min}}$	[mm]	40	45	55	65	90	120	135
Torque moment <sup>a)</sup>	$t_{\text{max}}$	[Nm]	10	20	40	80	150	200	300

a) This is the maximum recommended torque moment to avoid splitting failure during installation for anchors with minimum spacing and/or edge distance.

## HVU with HIS-(R)N adhesive anchor

Mortar System	Benefits
 <p>Hilti HVU foil capsule</p>  <p>Internal threaded sleeve HIS-N HIS-RN (A4-70)</p>	<ul style="list-style-type: none"> <li>■ suitable for non-cracked concrete C 20/25 to C 50/60</li> <li>■ high loading capacity</li> <li>■ suitable for dry and water saturated concrete</li> </ul>



Concrete



Small edge distance & spacing



Fire resistance



Corrosion resistance



European Technical Approval



CE conformity



PROFIS anchor design software

### Approvals / certificates

Description	Authority / Laboratory	No. / date of issue
European technical approval <sup>a)</sup>	DIBt, Berlin	ETA-05/0255 / 2011-06-23
Fire test report	IBMB, Braunschweig	UB-3333/0891-1 / 2004-03-26
Assessment report (fire)	warringtonfire	WF 166402 / 2007-10-26

a) All data given in this section according ETA-05/0255, issue 2011-06-23

### Service temperature range

Hilti HVU adhesive may be applied in the temperature ranges given below. An elevated base material temperature may lead to a reduction of the design bond resistance.

Temperature range	Base material temperature	Maximum long term base material temperature	Maximum short term base material temperature
Temperature range I	-40 °C to +40 °C	+24 °C	+40 °C
Temperature range II	-40 °C to +80 °C	+50 °C	+80 °C
Temperature range III	-40 °C to +120 °C	+72 °C	+120 °C

#### Max short term base material temperature

Short-term elevated base material temperatures are those that occur over brief intervals, e.g. as a result of diurnal cycling.

#### Max long term base material temperature

Long-term elevated base material temperatures are roughly constant over significant periods of time.



## Design process for typical anchor layouts

The design values in the tables are obtained from the design method according to ETAG 001, Annex C and Hilti simplified design method. Design resistance according to data given in ETA-05/0255, issue 2011-06-23.

- Influence of concrete strength
- Influence of edge distance
- Influence of spacing

The design method is based on the following simplification:

- No different loads are acting on individual anchors (no eccentricity)

The values are valid for the anchor configuration.

For more complex fastening applications please use the anchor design software PROFIS Anchor.

### STEP 1: TENSION LOADING

The design tensile resistance  $N_{Rd}$  is the lower of:

- Combined pull-out and concrete cone resistance

$$N_{Rd,p} = f_{B,p} \cdot N^*_{Rd,p}$$

$N^*_{Rd,p}$  is obtained from the relevant design tables

$f_{B,p}$  influence of concrete strength on combined pull-out and concrete cone resistance

Concrete Strengths $f'_{c,cyl}$ (MPa)	20	25	32	40	50
$f_{B,p}$	0.95	0.97	1.00	1.02	1.04

- Concrete cone or concrete splitting resistance

$$N_{Rd,c} = f_B \cdot N^*_{Rd,c}$$

$N^*_{Rd,c}$  is obtained from the relevant design tables

$f_B$  influence of concrete strength on concrete cone resistance

Concrete Strengths $f'_{c,cyl}$ (MPa)	20	25	32	40	50
$f_B$	0.79	0.87	1.00	1.11	1.22

- Design steel resistance (tension)  $N_{Rd,s}$

Anchor size			M8	M10	M12	M16	M20	
$N_{Rd,s}$	HIS-N	[kN]	17.5	30.7	44.7	80.3	74.1	
	HIS-RN	[kN]	13.9	21.9	31.6	58.8	69.2	
	Bolt	Grade 5.8	[kN]	12.0	19.3	28.0	52.7	82.0
	Bolt	Grade 8.8	[kN]	19.3	30.7	44.7	84.0	130.7
	Bolt	Grade A 4-70 / 316	[kN]	13.9	21.9	31.6	58.8	92.0

**Note:** Designer needs to check the bolt tensile resistance.

$$N_{Rd} = \min \{ N_{Rd,p}, N_{Rd,c}, N_{Rd,s} \}$$

**CHECK  $N_{Rd} \geq N_{Sd}$**

## STEP 2: SHEAR LOADING

The design shear resistance  $V_{Rd}$  is the lower of:

■ **Design Concrete Edge Resistance**

$$V_{Rd,c} = f_B \cdot V^*_{Rd,c}$$

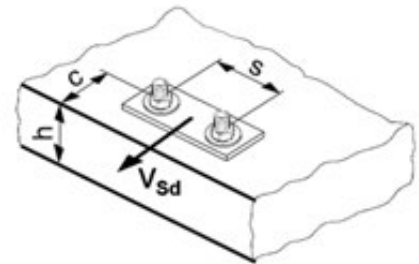

$V^*_{Rd,c}$  is obtained from the relevant design table

**$f_B$  influence of concrete strength**

Concrete Strengths $f'_{c,cyl}$ (MPa)	20	25	32	40	50
$f_B$	0.79	0.87	1.00	1.11	1.22

**Shear load acting parallel to edge:**

These tables are for a single free edge only

**2 anchors:**

For shear loads acting parallel to this edge, the concrete resistance  $V^*_{Rd,c}$  can be multiplied by the factor = 2.5

**4 anchors:**

For shear loads acting parallel to the edge - the anchor row closest to the edge is checked to resist half the total design load.

To obtain the concrete resistance use the corresponding 2 anchor configuration  $V^*_{Rd,c}$  and multiply by the factor = 2.5

■ **Design steel resistance (shear):  $V_{Rd,s}$**

Anchor size			M8	M10	M12	M16	M20
$V_{Rd,s}$	HIS-N	[kN]	10.4	18.4	26.0	39.3	36.7
	HIS-RN	[kN]	8.3	12.8	19.2	35.3	41.5
	Bolt	Grade 5.8 [kN]	7.2	12.0	16.8	31.2	48.8
	Bolt	Grade 8.8 [kN]	12.0	18.4	27.2	50.4	78.4
	Bolt	Grade A 4-70 / 316 [kN]	8.3	12.8	19.2	35.3	55.1

**Note:** Designer needs to check the bolt shear resistance.

$$V_{Rd} = \min \{ V_{Rd,c}, V_{Rd,s} \}$$

**CHECK  $V_{Rd} \geq V_{Sd}$**

## STEP 3: COMBINED TENSION AND SHEAR LOADING

The following equations must be satisfied:

$$N_{Sd}/N_{Rd} + V_{Sd}/V_{Rd} \leq 1.2$$

and

$$N_{Sd}/N_{Rd} \leq 1, V_{Sd}/V_{Rd} \leq 1$$

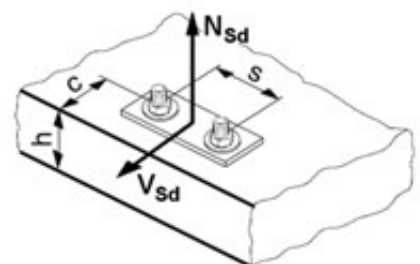

## Precalculated table values – design resistance values

### General:

The following tables provide the total ultimate limit state design resistance for the configurations. All tables are based upon:

- correct setting (See setting instruction)
- non-cracked concrete –  $f_{c,cyl} = 32$  MPa
- temperature range I (see service temperature range)
- base material thickness, as specified in the table
- One typical embedment depth, as specified in the tables

## Basic loading data (for a single anchor) – no edge distance and spacing influence

### Embedment depth and base material thickness for the basic loading data



Anchor size	M8	M10	M12	M16	M20
Embedment depth [mm]	90	110	125	170	205
Base material thickness [mm]	120	150	170	230	270

## Design resistance [kN] – uncracked concrete, 32 Mpa

Anchor size		M8	M10	M12	M16	M20
Non-cracked concrete						
Tensile	Pull-out $N_{Rd,p}^*$	19.0	30.4	45.7	72.3	106.6
	Concrete $N_{Rd,c}^*$	36.4	49.1	59.5	94.4	125.0
Shear	$V_{Rd,s}$	Steel governed refer $V_{Rd,s}$ table				

## Basic loading data (for a single anchor) – with minimum edge distance

### Design resistance [kN] - uncracked concrete, 32 Mpa

Anchor size		M8	M10	M12	M16	M20
Min. edge distance $c_{min}$ [mm]		40	45	60	80	125
Min Base thickness $h_{min}$ [mm]		120	150	170	230	270
<b>Tensile <math>N_{Rd}</math></b>						
	Pull-out $N_{Rd,p}^*$ [kN]	10.1	15.3	24.0	38.2	64.0
	Concrete $N_{Rd,c}^*$ [kN]	16.6	22.1	27.9	44.0	62.2
<b>Shear <math>V_{Rd}</math></b>						
	Shear $V_{Rd,c}$ (without lever arm)	5.3	7.0	10.7	17.4	32.1

## Two anchors

**Table 1:** One edge influence

Design Data:  $f_{c,cyl}=32$  MPa

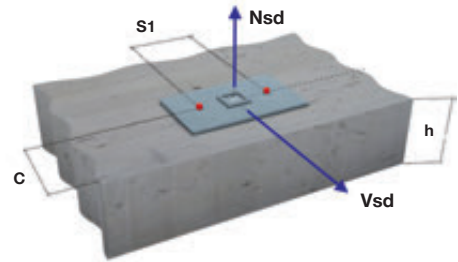

Anchor size	M8	M10	M12	M16	M20
Typical embedment depth $h_{ef}$ [mm]	90	110	125	170	205
Base material thickness $h$ [mm]	120	150	170	230	270

ANCHOR <b>M8</b>	Edge C (mm)														
	40			80			100			150			200		
	tension		shear	tension		shear	tension		shear	tension		shear	tension		shear
spacing $s_1$ (mm)	$N^*_{Rd,p}$	$N^*_{Rd,c}$	$V^*_{Rd,c}$	$N^*_{Rd,p}$	$N^*_{Rd,c}$	$V^*_{Rd,c}$	$N^*_{Rd,p}$	$N^*_{Rd,c}$	$V^*_{Rd,c}$	$N^*_{Rd,p}$	$N^*_{Rd,c}$	$V^*_{Rd,c}$	$N^*_{Rd,p}$	$N^*_{Rd,c}$	$V^*_{Rd,c}$
40	13.6	18.3	7.1	19.0	23.1	15.1	22.1	25.7	17.5	25.5	32.6	23.6	25.5	40.0	29.6
80	14.9	20.0	8.9	20.9	25.2	17.2	24.2	28.0	19.6	28.1	35.6	25.6	28.1	43.7	31.5
100	15.6	20.8	9.8	21.8	26.3	18.3	25.3	29.2	20.6	29.3	37.1	26.5	29.3	45.5	32.4
120	16.2	21.7	10.7	22.8	27.3	19.4	26.4	30.4	21.7	30.6	38.6	27.5	30.6	47.4	33.3
150	17.2	22.9	10.7	24.2	28.9	21.0	28.0	32.1	23.2	32.4	40.9	28.9	32.5	50.1	34.7
200	18.9	25.0	10.7	26.5	31.5	23.7	30.7	35.1	25.8	35.5	44.6	31.4	35.5	54.7	37.0

ANCHOR <b>M10</b>	Edge C (mm)														
	45			80			100			150			200		
	tension		shear	tension		shear	tension		shear	tension		shear	tension		shear
spacing $s_1$ (mm)	$N^*_{Rd,p}$	$N^*_{Rd,c}$	$V^*_{Rd,c}$	$N^*_{Rd,p}$	$N^*_{Rd,c}$	$V^*_{Rd,c}$	$N^*_{Rd,p}$	$N^*_{Rd,c}$	$V^*_{Rd,c}$	$N^*_{Rd,p}$	$N^*_{Rd,c}$	$V^*_{Rd,c}$	$N^*_{Rd,p}$	$N^*_{Rd,c}$	$V^*_{Rd,c}$
45	19.8	24.3	9.3	25.1	28.9	16.8	28.4	31.7	21.7	37.4	39.2	28.7	39.3	47.4	35.6
100	22.0	26.8	12.1	27.9	32.0	20.1	31.6	35.1	25.1	41.6	43.4	31.9	43.7	52.5	38.7
150	24.0	29.2	13.9	30.5	34.8	23.0	34.5	38.1	28.3	45.5	47.2	34.8	47.7	57.1	41.4
200	26.0	31.5	13.9	33.0	37.5	26.0	37.3	41.2	31.4	49.3	51.0	37.7	51.7	61.7	44.2
250	28.0	33.9	13.9	35.5	40.3	28.3	40.2	44.3	34.6	53.0	54.7	40.6	55.6	66.2	47.0
300	29.9	36.2	13.9	37.9	43.1	28.3	42.9	47.3	37.7	56.6	58.5	43.5	59.4	70.8	49.7

ANCHOR <b>M12</b>	Edge C (mm)														
	60			80			100			150			200		
	tension		shear	tension		shear	tension		shear	tension		shear	tension		shear
spacing $s_1$ (mm)	$N^*_{Rd,p}$	$N^*_{Rd,c}$	$V^*_{Rd,c}$	$N^*_{Rd,p}$	$N^*_{Rd,c}$	$V^*_{Rd,c}$	$N^*_{Rd,p}$	$N^*_{Rd,c}$	$V^*_{Rd,c}$	$N^*_{Rd,p}$	$N^*_{Rd,c}$	$V^*_{Rd,c}$	$N^*_{Rd,p}$	$N^*_{Rd,c}$	$V^*_{Rd,c}$
60	30.1	31.0	14.3	33.8	33.9	19.1	37.7	36.8	24.2	48.4	44.7	33.4	57.2	53.2	40.9
100	32.4	33.1	16.7	36.4	36.1	21.6	40.6	39.3	26.9	52.1	47.7	36.0	61.6	56.8	43.3
150	35.2	35.7	19.7	39.6	39.0	24.8	44.2	42.4	30.2	56.8	51.4	39.3	67.1	61.2	46.4
200	38.1	38.3	21.5	42.9	41.8	28.0	47.8	45.4	33.6	61.4	55.1	42.5	72.6	65.7	49.5
250	41.0	40.9	21.5	46.1	44.6	30.5	51.4	48.5	37.0	66.0	58.9	45.8	78.0	70.1	52.6
300	43.8	43.5	21.5	49.2	47.5	30.5	55.0	51.6	40.3	70.5	62.6	49.1	83.4	74.6	55.7

ANCHOR <b>M16</b>	Edge C (mm)														
	80			100			150			200			250		
	tension		shear	tension		shear	tension		shear	tension		shear	tension		shear
spacing s1 (mm)	N*Rd,p	N*Rd,c	V*Rrd,c	N*Rd,p	N*Rd,c	V*Rrd,c	N*Rd,p	N*Rd,c	V*Rrd,c	N*Rd,p	N*Rd,c	V*Rrd,c	N*Rd,p	N*Rd,c	V*Rrd,c
80	48.0	48.7	23.3	52.6	52.0	28.9	64.6	60.6	44.3	77.9	69.7	53.8	90.8	79.4	62.7
100	49.4	49.9	24.7	54.1	53.3	30.4	66.5	62.0	46.0	80.1	71.4	55.3	93.5	81.4	64.2
150	52.9	52.9	28.4	57.9	56.5	34.2	71.2	65.8	50.1	85.8	75.7	59.3	100.1	86.2	67.9
200	56.4	55.9	32.0	61.8	59.7	38.0	75.9	69.5	54.3	91.5	80.0	63.3	106.7	91.1	71.7
250	59.9	58.9	34.9	65.6	62.9	41.8	80.7	73.2	58.5	97.1	84.2	67.2	113.3	96.0	75.5
300	63.4	61.9	34.9	69.4	66.0	45.6	85.3	76.9	62.7	102.8	88.5	71.2	119.9	108.0	79.3

ANCHOR <b>M20</b>	Edge C (mm)														
	125			150			200			250			300		
	tension		shear	tension		shear	tension		shear	tension		shear	tension		shear
spacing s1 (mm)	N*Rd,p	N*Rd,c	V*Rrd,c	N*Rd,p	N*Rd,c	V*Rrd,c	N*Rd,p	N*Rd,c	V*Rrd,c	N*Rd,p	N*Rd,c	V*Rrd,c	N*Rd,p	N*Rd,c	V*Rrd,c
125	81.7	70.8	42.7	89.4	75.3	51.2	105.9	84.9	65.7	123.7	95.0	75.3	136.0	105.6	84.9
150	84.3	72.5	44.9	92.3	77.2	53.4	109.3	86.9	68.0	127.7	97.3	77.5	140.4	108.1	87.0
200	89.6	75.9	49.2	98.1	80.8	57.8	116.2	91.0	72.5	135.7	101.8	81.8	149.3	113.2	91.1
250	94.9	79.3	53.4	103.9	84.4	62.3	123.1	95.1	77.0	143.7	106.4	86.1	158.1	118.3	95.3
300	100.2	82.7	57.7	109.7	88.0	66.7	129.9	99.2	81.5	151.7	111.0	90.4	166.9	123.3	99.4
350	105.4	86.1	62.0	115.5	91.7	71.2	136.8	103.3	86.1	159.7	115.5	94.7	175.7	128.4	103.5



## Four anchors

**Table 2:** One edge influence

Design Data:  $f_{c,cyl}=32$  MPa

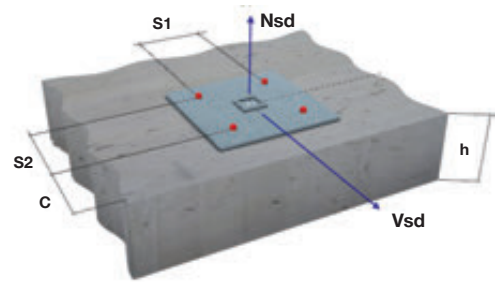

Anchor size	M8	M10	M12	M16	M20
Typical embedment depth $h_{ef}$ [mm]	90	110	125	170	205
Base material thickness $h$ [mm]	120	150	170	230	270

ANCHOR <b>M8</b>	Edge C (mm)														
	40			80			100			150			200		
	tension		shear	tension		shear	tension		shear	tension		shear	tension		shear
spacing $s1 = s2$ (mm)	$N^*_{Rd,p}$	$N^*_{Rd,c}$	$V^*_{Rd,c}$	$N^*_{Rd,p}$	$N^*_{Rd,c}$	$V^*_{Rd,c}$	$N^*_{Rd,p}$	$N^*_{Rd,c}$	$V^*_{Rd,c}$	$N^*_{Rd,p}$	$N^*_{Rd,c}$	$V^*_{Rd,c}$	$N^*_{Rd,p}$	$N^*_{Rd,c}$	$V^*_{Rd,c}$
40	20.1	21.4	14.2	27.1	26.4	20.0	30.9	29.1	22.4	35.3	36.4	28.4	35.3	44.1	34.3
80	25.4	26.7	17.8	33.3	32.4	26.8	37.6	35.5	29.1	42.5	43.8	35.0	42.5	52.5	40.8
100	28.2	29.6	19.6	36.6	35.7	30.1	41.2	39.0	32.4	46.3	47.8	38.2	46.3	57.0	44.0
120	31.2	32.6	21.4	40.0	39.1	33.3	44.8	42.6	35.6	50.3	51.9	41.4	50.3	61.7	47.1
150	35.7	37.4	21.4	45.3	44.5	38.2	50.5	48.3	40.5	56.4	58.5	46.2	56.4	69.1	51.8
200	43.6	46.0	21.4	54.5	54.2	46.1	60.3	58.6	48.4	66.9	70.2	54.0	66.9	82.4	59.6

ANCHOR <b>M10</b>	Edge C (mm)														
	45			80			100			150			200		
	tension		shear	tension		shear	tension		shear	tension		shear	tension		shear
spacing $s1 = s2$ (mm)	$N^*_{Rd,p}$	$N^*_{Rd,c}$	$V^*_{Rd,c}$	$N^*_{Rd,p}$	$N^*_{Rd,c}$	$V^*_{Rd,c}$	$N^*_{Rd,p}$	$N^*_{Rd,c}$	$V^*_{Rd,c}$	$N^*_{Rd,p}$	$N^*_{Rd,c}$	$V^*_{Rd,c}$	$N^*_{Rd,p}$	$N^*_{Rd,c}$	$V^*_{Rd,c}$
45	28.1	28.1	18.5	34.7	33.0	25.2	38.8	35.9	28.0	49.9	43.8	34.9	52.2	52.3	41.8
100	36.6	36.4	24.2	44.3	42.1	36.0	49.0	45.5	38.7	61.7	54.6	45.4	64.3	64.5	52.0
150	45.3	44.8	27.8	53.9	51.2	45.4	59.2	55.1	48.0	73.4	65.5	54.6	76.3	76.7	61.1
200	54.5	54.0	27.8	64.2	61.3	52.0	70.0	65.7	57.2	85.9	77.3	63.7	89.1	89.9	70.1
250	64.2	64.0	27.8	75.0	72.2	56.7	81.5	77.2	66.2	98.9	90.2	72.6	102.5	104.2	79.0
300	74.4	74.9	27.8	86.2	84.1	56.8	93.4	89.6	75.1	112.5	104.0	81.5	116.4	119.6	87.8

ANCHOR <b>M12</b>	Edge C (mm)														
	60			80			100			150			200		
	tension		shear	tension		shear	tension		shear	tension		shear	tension		shear
spacing $s1 = s2$ (mm)	$N^*_{Rd,p}$	$N^*_{Rd,c}$	$V^*_{Rd,c}$	$N^*_{Rd,p}$	$N^*_{Rd,c}$	$V^*_{Rd,c}$	$N^*_{Rd,p}$	$N^*_{Rd,c}$	$V^*_{Rd,c}$	$N^*_{Rd,p}$	$N^*_{Rd,c}$	$V^*_{Rd,c}$	$N^*_{Rd,p}$	$N^*_{Rd,c}$	$V^*_{Rd,c}$
60	41.3	36.7	28.6	45.7	39.7	31.9	50.4	42.8	34.9	63.0	51.1	42.4	73.4	60.0	49.7
100	49.3	43.2	33.4	54.3	46.5	40.4	59.4	49.9	43.4	73.4	59.0	50.6	84.7	68.9	57.9
150	60.3	52.0	40.0	65.9	55.7	49.6	71.8	59.6	53.6	87.4	69.8	60.8	100.1	80.8	67.9
200	72.3	61.6	42.9	78.6	65.7	56.0	85.1	70.1	63.7	102.6	81.5	70.7	116.7	93.7	77.7
250	85.1	71.9	43.0	92.1	76.6	61.0	99.4	81.4	73.5	118.7	94.0	80.5	134.4	107.5	87.4
300	98.8	83.1	43.0	106.5	88.3	61.0	114.5	93.5	80.6	135.8	107.4	90.1	153.0	122.3	97.0

**Shear design:** The concrete edge resistance value in this table uses all 4 anchors in shear. You will need to ensure the gap between anchor and the plate is filled. This can be achieved using the Hilti Dynamic Set. (Refer page 41 for further details)

The concrete edge resistance values have been obtained by taking the lesser of:

1. First row resistance multiplied by number of rows and
2. The concrete edge resistance of the furthest row.

ANCHOR <b>M16</b>	Edge C (mm)														
	80			100			150			200			250		
	tension		shear	tension		shear	tension		shear	tension		shear	tension		shear
spacing s1= s2 (mm)	N*Rd,p	N*Rd,c	V*Rrd,c	N*Rd,p	N*Rd,c	V*Rrd,c	N*Rd,p	N*Rd,c	V*Rrd,c	N*Rd,p	N*Rd,c	V*Rrd,c	N*Rd,p	N*Rd,c	V*Rrd,c
80	66.1	57.5	46.5	71.5	60.9	50.2	85.9	69.9	59.1	101.5	79.5	67.9	116.7	89.7	76.7
100	70.9	61.1	49.5	76.5	64.7	55.3	91.4	74.0	64.2	107.6	84.0	72.9	123.4	94.5	81.6
150	83.5	70.6	56.7	89.7	74.6	67.9	106.1	84.8	76.5	123.9	95.7	85.1	141.2	107.2	93.6
200	97.1	80.9	64.0	103.9	85.1	76.0	121.9	96.3	88.6	141.2	108.1	97.1	160.1	120.6	105.5
250	111.6	91.8	69.8	119.0	96.4	83.6	138.6	108.5	100.5	159.6	121.3	108.9	180.0	134.8	117.1
300	126.8	103.3	69.8	134.9	108.4	91.2	156.1	121.4	112.3	178.9	135.2	120.5	201.0	149.8	128.7

ANCHOR <b>M20</b>	Edge C (mm)														
	125			150			200			250			300		
	tension		shear	tension		shear	tension		shear	tension		shear	tension		shear
spacing s1= s2 (mm)	N*Rd,p	N*Rd,c	V*Rrd,c	N*Rd,p	N*Rd,c	V*Rrd,c	N*Rd,p	N*Rd,c	V*Rrd,c	N*Rd,p	N*Rd,c	V*Rrd,c	N*Rd,p	N*Rd,c	V*Rrd,c
125	113.2	86.0	75.3	122.3	90.9	80.1	141.5	101.1	89.7	162.1	111.8	99.2	176.3	123.0	108.6
150	121.8	91.1	82.2	131.3	96.2	87.0	151.4	106.8	96.4	172.9	117.9	105.8	187.7	129.5	115.2
200	139.9	101.9	95.8	150.3	107.4	100.4	172.2	118.7	109.7	195.5	130.6	119.0	211.6	143.1	128.2
250	159.1	113.3	106.9	170.4	119.2	113.7	194.2	131.3	122.8	219.5	144.0	132.0	237.0	157.3	141.1
300	179.5	125.3	115.4	191.7	131.5	126.7	217.4	144.5	135.7	244.8	158.1	144.8	263.6	172.2	153.8
350	200.9	137.8	124.0	214.2	144.5	139.5	241.9	158.3	148.5	271.3	172.7	157.5	291.6	187.8	166.4

## Materials

### Mechanical properties of HIS-(R)N

Anchor size			M8x90	M10x110	M12x125	M16x170	M20x205
Nominal tensile strength $f_{uk}$	HIS-N	[N/mm <sup>2</sup> ]	490	490	460	460	460
	Screw 8.8	[N/mm <sup>2</sup> ]	800	800	800	800	800
	HIS-RN	[N/mm <sup>2</sup> ]	700	700	700	700	700
	Screw A4-70	[N/mm <sup>2</sup> ]	700	700	700	700	700
Yield strength $f_{yk}$	HIS-N	[N/mm <sup>2</sup> ]	410	410	375	375	375
	Screw 8.8	[N/mm <sup>2</sup> ]	640	640	640	640	640
	HIS-RN	[N/mm <sup>2</sup> ]	350	350	350	350	350
	Screw A4-70	[N/mm <sup>2</sup> ]	450	450	450	450	450
Stressed cross-section $A_s$	HIS-(R)N	[mm <sup>2</sup> ]	51.5	108.0	169.1	256.1	237.6
	Screw	[mm <sup>2</sup> ]	36.6	58	84.3	157	245
Section modulus Z	HIS-(R)N	[mm <sup>3</sup> ]	145	430	840	1595	1543
	Screw	[mm <sup>3</sup> ]	31.2	62.3	109	277	541

## Material quality

Part	Material
Internal threaded sleeve <sup>a)</sup> HIS-N	C-steel 1.0718 Steel galvanized $\geq 5\mu\text{m}$
Internal threaded sleeve <sup>b)</sup> HIS-RN	Stainless steel 1.4401; 1.4571

a) related fastening screw: strength class 8.8 EN ISO 898-1,  $A_s > 8\%$  Ductile steel galvanized  $\geq 5\mu\text{m}$

b) related fastening screw: strength class 70 EN ISO 3506-1,  $A_s > 8\%$  Ductile stainless steel 1.4401; 1.4404; 1.4578; 1.4571; 1.4439; 1.4362

## Anchor dimensions

Anchor size	M8	M10	M12	M16	M20
Internal sleeve HIS-(R)N	M8x90	M10x110	M12x125	M16x170	M20x205
Anchor embedment depth [mm]	90	110	125	170	205

## Setting

### Installation equipment

Anchor size	M8	M10	M12	M16	M20
Rotary hammer	TE 2 – TE 30		TE 40 – TE 70		
Other tools	blow out pump or compressed air gun, setting tools				

### Setting instructions

Dry and water-saturated concrete, hammer drilling

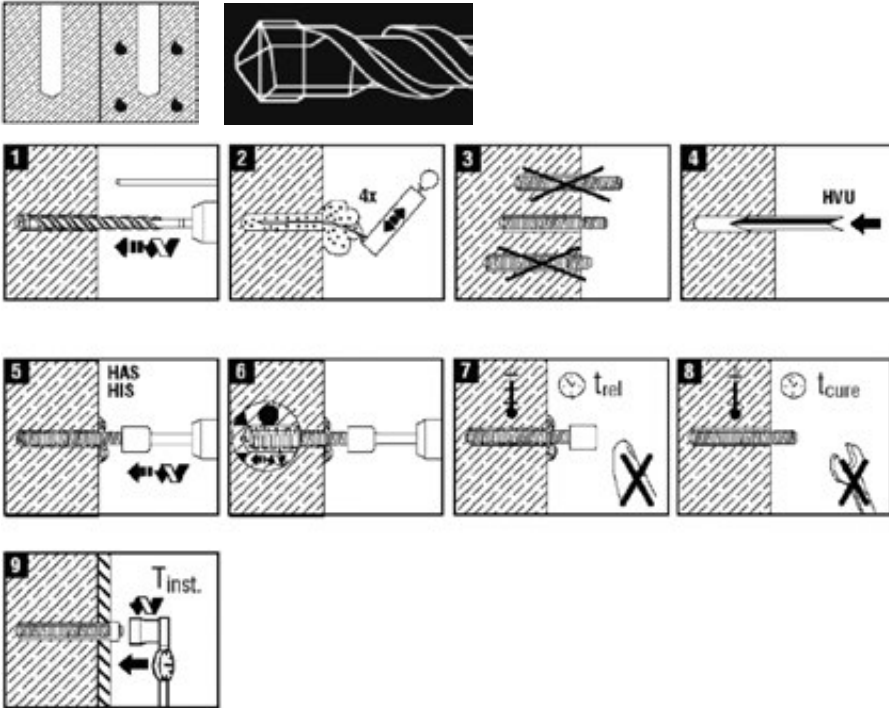

For detailed information on installation see instruction for use given with the package of the product.

## Curing time for general conditions

Data according ETA-05/0255, issue 2011-06-23	
Temperature of the base material	Curing time before anchor can be fully loaded $t_{\text{cure}}$
20 °C to 40 °C	20 min
10 °C to 19 °C	30 min
0 °C to 9 °C	1 h
-5 °C to - 1 °C	5 h



## Setting details

		Data according ETA-05/0255, issue 2011-06-23				
Anchor size	Sleeve HIS-(R)N foil capsule	M8x90 M10x90	M10x110 M12x110	M12x125 M16x125	M16x170 M20x170	M20x205 M24x210
Nominal diameter of drill bit	$d_0$ [mm]	14	18	22	28	32
Diameter of element	$d$ [mm]	12.5	16.5	20.5	25.4	27.6
Effective anchorage and drill hole depth	$h_{\text{ef,min}}$ [mm]	90	110	125	170	205
Diameter of clearance hole in the fixture	$d_f$ [mm]	9	12	14	18	22
Thread engagement length; min - max	$h_s$ [mm]	8-20	10-25	12-30	16-40	20-50
Minimum spacing	$s_{\text{min}}$ [mm]	40	45	60	80	125
Minimum edge distance	$c_{\text{min}}$ [mm]	40	45	60	80	125
Torque moment <sup>a)</sup>	$t_{\text{max}}$ [Nm]	10	20	40	80	150

a) This is the maximum recommended torque moment to avoid splitting failure during installation for anchors with minimum spacing and/or edge distance.



## Hilti HIT-HY 200 with HIT-V

Injection Mortar System	Benefits
 <p>Hilti HIT-HY 200-R 500 ml foil pack (also available as 330 ml foil pack)</p>	<ul style="list-style-type: none"> <li>■ Suitable for non-cracked and cracked concrete C 20/25 to C 50/60</li> <li>■ Suitable for dry and water saturated concrete</li> <li>■ High loading capacity, excellent handling and fast curing</li> <li>■ Small edge distance and anchor spacing possible</li> <li>■ Large diameter applications</li> <li>■ Max In service temperature range up to 120°C short term/ 72°C long term</li> <li>■ Manual cleaning for borehole diameter up to 20 mm and hef ≤ 10d for non-cracked concrete only</li> <li>■ Embedment depth range: from 60 ... 160 mm for M8 to 120 ... 600 mm for M30</li> </ul>
 <p>Static mixer</p>	
 <p>HIT-V rods HIT-V (Zinc) HIT-V-F (Gal) HIT-V-R (A4-70) HIT-V-HCR rods</p>	



Concrete



Tensile zone



Small edge distance & spacing



Variable embedment depth



Corrosion resistance



High corrosion resistance



European Technical Approval



CE conformity



PROFIS anchor design software



SAFEset approved automatic cleaning

### Approvals / certificates

Description	Authority / Laboratory	No. / date of issue
European technical approval <sup>a)</sup>	DIBt, Berlin	ETA-12/0084 / 2013-06-20 (Hilti HIT-HY 200-R)
Fire test report	IBMB, Brunswick	3501/676/13 / 2012-08-03

a) All data given in this section according ETA-12/0084, issue 2013-06-20.

### Service temperature range

Hilti HIT-HY 200 injection mortar may be applied in the temperature ranges given below. An elevated base material temperature may lead to a reduction of the design bond resistance.

Temperature range	Base material temperature	Maximum long term base material temperature	Maximum short term base material temperature
Temperature range I	-40 °C to +40 °C	+24 °C	+40 °C
Temperature range II	-40 °C to +80 °C	+50 °C	+80 °C
Temperature range III	-40 °C to +120 °C	+72 °C	+120 °C

#### Max short term base material temperature

Short-term elevated base material temperatures are those that occur over brief intervals, e.g. as a result of diurnal cycling.

#### Max long term base material temperature

Long-term elevated base material temperatures are roughly constant over significant periods of time

## Design process for typical anchor layouts

The design values in the tables are obtained from Profis V2.2.1 in compliance with the design method according to EOTA TR 029. Design resistance according to data given in ETA-12/0084, issue 2013-06-20.

- Influence of concrete strength
- Influence of edge distance
- Influence of spacing

The design method is based on the following simplification:

- No different loads are acting on individual anchors (no eccentricity)

The values are valid for the anchor configuration.

For more complex fastening applications please use the anchor design software PROFIS Anchor.

### STEP 1: TENSION LOADING

The design tensile resistance  $N_{Rd}$  is the lower of:

- Combined pull-out and concrete cone resistance

$$N_{Rd,p} = f_{B,p} \cdot N^*_{Rd,p}$$

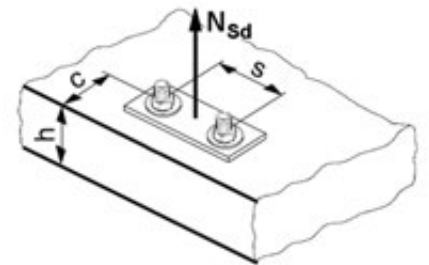

$N^*_{Rd,p}$  is obtained from the relevant design tables

$f_{B,p}$  influence of concrete strength on combined pull-out and concrete cone resistance

Concrete Strengths $f'_{c,cyl}$ (MPa)	20	25	32	40	50
$f_{B,p}$	1.00	1.00	1.00	1.00	1.00

- Concrete cone or concrete splitting resistance

$$N_{Rd,c} = f_B \cdot N^*_{Rd,c}$$

$N^*_{Rd,c}$  is obtained from the relevant design tables

$f_B$  influence of concrete strength on concrete cone resistance

Concrete Strengths $f'_{c,cyl}$ (MPa)	20	25	32	40	50
$f_B$	0.79	0.87	1.00	1.11	1.22

- Design steel resistance (tension)  $N_{Rd,s}$

Anchor size		M8	M10	M12	M16	M20	M24	
$N_{Rd,s}$	HIT-V 5.8	[kN]	12.0	19.3	28.0	52.7	82.0	118.0
	HIT-V 8.8	[kN]	19.3	30.7	44.7	84.0	130.7	188.0
	HIT-V-R	[kN]	13.9	21.9	31.6	58.8	92.0	132.1

$$N_{Rd} = \min \{ N_{Rd,p}, N_{Rd,c}, N_{Rd,s} \}$$

$$\text{CHECK } N_{Rd} \geq N_{Sd}$$

**STEP 2: SHEAR LOADING**

The design shear resistance  $V_{Rd}$  is the lower of:

■ **Design Concrete Edge Resistance**

$$V_{Rd,c} = f_B \cdot V^*_{Rd,c} \cdot \psi_{re,V}$$

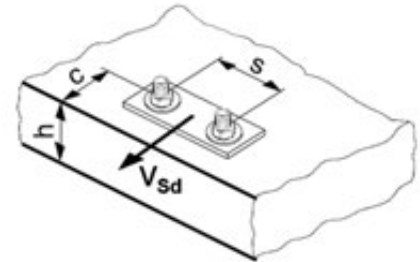

$V^*_{Rd,c}$  is obtained from the relevant design table

The factor  $\psi_{re,V}$  takes account of the effect of the type of reinforcement used in cracked concrete.

$\psi_{re,V} = 1.0$  anchorage in non-cracked concrete

$\psi_{re,V} = 1.0$  anchorage in cracked concrete without edge reinforcement

$\psi_{re,V} = 1.2$  anchorage in cracked concrete with straight edge reinforcement ( $\geq \phi 12$  mm)

$\psi_{re,V} = 1.4$  anchorage in cracked concrete with edge reinforcement and closely spaced stirrups ( $a \leq 100$  mm)

**$f_B$  influence of concrete strength**

Concrete Strengths $f'_{c,cyl}$ (MPa)	20	25	32	40	50
$f_B$	0.79	0.87	1.00	1.11	1.22

**Shear load acting parallel to edge:**

These tables are for a single free edge only

**2 anchors:**

For shear loads acting parallel to this edge, the concrete resistance  $V^*_{Rd,c}$  can be multiplied by the factor = 2.5

**4 anchors:**

For shear loads acting parallel to the edge - the anchor row closest to the edge is checked to resist half the total design load. To obtain the concrete resistance use the corresponding 2 anchor configuration  $V^*_{Rd,c}$  and multiply by the factor = 2.5

■ **Design steel resistance (shear):  $V_{Rd,s}$**

Anchor size		M8	M10	M12	M16	M20	M24	
$V_{Rd,s}$	HIT-V 5.8	[kN]	7.2	12.0	16.8	31.2	48.8	70.4
	HIT-V 8.8	[kN]	12.0	18.4	27.2	50.4	78.4	112.8
	HIT-V-R	[kN]	8.3	12.8	19.2	35.3	55.1	79.5

$$V_{Rd} = \min \{ V_{Rd,c}, V_{Rd,s} \}$$

**CHECK  $V_{Rd} \geq V_{Sd}$**

**STEP 3: COMBINED TENSION AND SHEAR LOADING**

The following equations must be satisfied:

$$N_{Sd}/N_{Rd} + V_{Sd}/V_{Rd} \leq 1.2$$

and

$$N_{Sd}/N_{Rd} \leq 1, V_{Sd}/V_{Rd} \leq 1$$

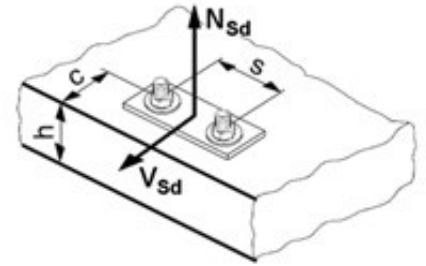

## Precalculated table values – design resistance values

### General:

The following tables provide the total ultimate limit state design resistance for the configurations.

All tables are based upon:

- correct setting (See setting instruction)
- non cracked and cracked concrete –  $f_{c,cyl} = 32$  MPa
- temperature range I (see service temperature range)
- base material thickness, as specified in the table
- One typical embedment depth, as specified in the tables

The following tables give design values for typical embedment depths. The latest version of the Hilti software Profis allows the engineer to optimise their design by varying the embedment depth according to the applied loads to achieve an economical solution every time. This is done by selecting HIT-V-Rods.

For more information on the HIT-V rods please refer to the Chemical Anchor Components & Accessories section on page 240.

The anchor design software program Profis can be download from the Hilti Australia website, [www.hilti.com.au](http://www.hilti.com.au).

## Basic loading data (for a single anchor) – no edge distance and spacing influence

### Embedment depth and base material thickness for the basic loading data



Anchor size	M8	M10	M12	M16	M20	M24
Typical embedment depth $h_{ef}$ [mm]	80	90	110	125	170	210
Base material thickness $h$ [mm]	110	120	150	200	250	300

### Design resistance: concrete 32 MPa

Anchor size		M8	M10	M12	M16	M20	M24
Non-cracked concrete							
Tensile	Concrete Pull $N_{Rd,p}^*$	Steel governed refer $N_{Rd,s}$ table			69.8	118.7	175.9
	Concrete Cone $N_{Rd,c}^*$	Steel governed refer $N_{Rd,s}$ table			49.6	78.7	108.0
Shear	$V_{Rd,s}$	Steel governed refer $V_{Rd,s}$ table					
Cracked concrete							
Tensile	Concrete Pull $N_{Rd,p}^*$	6.7	9.4	18.4	27.9	47.5	70.4
	Concrete Cone $N_{Rd,c}^*$	18.1	21.6	29.2	35.4	56.1	77.0
Shear	$V_{Rd,s}$	NA	Steel governed refer $V_{Rd,s}$ table				

## Basic loading data (for a single anchor) – with minimum edge distance

### Design resistance [kN] - uncracked concrete, 32 Mpa

Anchor size		M8	M10	M12	M16	M20	M24	
Min. edge distance	$c_{min}$ [mm]	40	50	60	80	100	120	
Base thickness	$h$ [mm]	110	120	150	200	250	300	
<b>Tensile <math>N_{Rd}</math></b>								
	Pull-out	$N_{Rd,p}^*$ [kN]	11.9	17.5	25.4	41.2	67.5	98.9
	Concrete	$N_{Rd,c}^*$ [kN]	12.1	14.7	20.9	29.3	44.8	58.8
<b>Shear <math>V_{Rd}</math></b>								
	Shear (without lever arm)	$V_{Rd,c}$	4.7	6.7	9.3	14.5	21.7	29.8



Tensile zone

### Design resistance [kN] - cracked concrete, 32 Mpa

Anchor size		M8	M10	M12	M16	M20	M24	
Min. edge distance	$c_{min}$ [mm]	40	50	60	80	100	120	
Base thickness	$h$ [mm]	110	120	150	200	250	300	
<b>Tensile <math>N_{Rd}</math></b>								
	Pull-out	$N_{Rd,p}^*$ [kN]	3.6	5.2	10.2	16.5	27.0	39.6
	Concrete	$N_{Rd,c}^*$ [kN]	8.6	10.5	14.9	20.8	31.9	41.9
<b>Shear <math>V_{Rd}</math></b>								
	Shear (without lever arm)	$V_{Rd,c}$	3.3	4.8	6.6	10.3	15.4	21.1

## Two anchors

**Table 1:** One edge influence – non cracked concrete

Design Data:  $f_{c,cyl}=32$  MPa

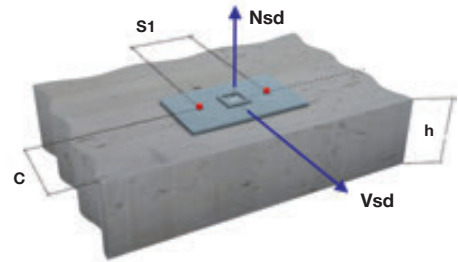

Anchor size	M8	M10	M12	M16	M20	M24
Typical embedment depth $h_{ef}$ [mm]	80	90	110	125	170	210
Base material thickness $h$ [mm]	110	120	150	200	250	300

ANCHOR <b>M8</b>	Edge C (mm)														
	40			80			100			150			170		
	tension		shear	tension		shear	tension		shear	tension		shear	tension		shear
spacing $s_1$ (mm)	$N^*_{Rd,p}$	$N^*_{Rd,c}$	$V^*_{Rd,c}$	$N^*_{Rd,p}$	$N^*_{Rd,c}$	$V^*_{Rd,c}$	$N^*_{Rd,p}$	$N^*_{Rd,c}$	$V^*_{Rd,c}$	$N^*_{Rd,p}$	$N^*_{Rd,c}$	$V^*_{Rd,c}$	$N^*_{Rd,p}$	$N^*_{Rd,c}$	$V^*_{Rd,c}$
40	14.5	13.5	6.3	20.4	17.6	13.2	13.6	19.8	15.4	27.1	25.8	21.0	27.1	28.4	23.2
80	16.4	14.9	7.9	23.0	19.4	15.0	26.7	21.8	17.2	30.7	28.5	22.7	30.7	31.4	24.9
100	17.3	15.6	8.6	24.3	20.3	15.9	28.2	22.9	18.1	32.4	29.8	23.6	32.4	32.9	25.7
120	18.2	16.4	9.4	25.6	21.2	16.9	29.8	23.9	19.0	34.2	31.2	24.4	34.2	34.4	26.6
150	19.7	17.4	9.4	27.6	22.6	18.3	32.1	25.5	20.4	36.8	33.2	25.7	36.8	36.6	27.9
200	22.0	19.2	9.4	30.9	24.9	20.6	35.9	28.1	22.6	41.2	36.6	27.9	41.2	43.0	30.0

ANCHOR <b>M10</b>	Edge C (mm)														
	50			80			100			150			200		
	tension		shear	tension		shear	tension		shear	tension		shear	tension		shear
spacing $s_1$ (mm)	$N^*_{Rd,p}$	$N^*_{Rd,c}$	$V^*_{Rd,c}$	$N^*_{Rd,p}$	$N^*_{Rd,c}$	$V^*_{Rd,c}$	$N^*_{Rd,p}$	$N^*_{Rd,c}$	$V^*_{Rd,c}$	$N^*_{Rd,p}$	$N^*_{Rd,c}$	$V^*_{Rd,c}$	$N^*_{Rd,p}$	$N^*_{Rd,c}$	$V^*_{Rd,c}$
50	20.7	16.6	9.0	26.0	19.7	15.0	29.9	21.9	17.4	37.2	27.8	23.4	37.2	34.1	29.3
100	23.9	18.4	11.3	30.1	21.9	17.6	34.6	24.3	19.9	43.1	30.9	25.7	43.1	38.0	31.5
150	27.2	20.3	13.5	34.2	24.1	20.2	39.2	26.8	22.4	48.9	34.1	28.1	48.9	41.8	33.8
200	30.4	22.2	13.5	38.2	26.3	22.8	43.9	29.2	24.9	54.7	37.2	30.4	54.7	45.6	36.0
250	33.6	24.0	13.5	42.3	28.5	24.8	48.6	31.7	27.4	60.5	40.3	32.7	60.5	49.4	38.3
300	34.9	25.9	13.5	43.9	30.7	24.8	50.4	34.1	29.9	62.8	43.4	35.1	62.8	53.3	40.6

ANCHOR <b>M12</b>	Edge C (mm)														
	60			80			100			150			200		
	tension		shear	tension		shear	tension		shear	tension		shear	tension		shear
spacing $s_1$ (mm)	$N^*_{Rd,p}$	$N^*_{Rd,c}$	$V^*_{Rd,c}$	$N^*_{Rd,p}$	$N^*_{Rd,c}$	$V^*_{Rd,c}$	$N^*_{Rd,p}$	$N^*_{Rd,c}$	$V^*_{Rd,c}$	$N^*_{Rd,p}$	$N^*_{Rd,c}$	$V^*_{Rd,c}$	$N^*_{Rd,p}$	$N^*_{Rd,c}$	$V^*_{Rd,c}$
60	30.0	23.5	12.3	34.2	25.9	16.7	38.6	28.5	21.4	50.6	35.2	28.2	54.5	42.6	35.0
100	33.1	25.3	14.4	37.7	27.9	18.9	42.5	30.6	23.8	55.7	37.8	30.5	60.0	45.8	37.1
150	37.0	27.5	16.9	42.1	30.3	21.7	47.5	33.3	26.7	62.2	41.1	33.2	67.0	49.8	39.7
200	40.8	29.7	18.5	46.5	32.8	24.5	52.4	35.9	29.7	68.7	44.5	36.0	74.0	53.8	42.4
250	44.7	31.9	18.5	50.8	35.2	26.7	57.3	38.6	32.7	75.2	47.8	38.7	81.0	57.8	45.0
300	48.5	34.1	18.5	55.2	37.6	26.7	62.3	41.3	35.7	81.7	51.1	41.5	88.0	61.8	47.7



ANCHOR <b>M16</b>	Edge C (mm)														
	80			100			150			200			250		
	tension		shear	tension		shear	tension		shear	tension		shear	tension		shear
spacing s1 (mm)	N*Rd,p	N*Rd,c	V*Rrd,c	N*Rd,p	N*Rd,c	V*Rrd,c	N*Rd,p	N*Rd,c	V*Rrd,c	N*Rd,p	N*Rd,c	V*Rrd,c	N*Rd,p	N*Rd,c	V*Rrd,c
80	50.0	35.5	19.3	55.9	39.7	24.4	71.7	50.9	36.2	84.7	60.2	44.1	84.7	60.2	52.0
100	52.2	37.1	20.5	58.3	41.4	25.7	74.8	53.1	37.5	88.4	62.8	45.4	88.4	62.8	53.2
150	57.7	41.0	23.6	64.4	45.8	28.9	82.7	58.7	41.0	97.7	69.4	48.6	97.7	69.4	56.3
200	63.2	44.9	26.6	70.6	50.1	32.1	90.6	64.3	44.4	107.0	76.0	51.9	107.0	76.0	59.4
250	68.7	48.8	29.1	76.7	54.5	35.3	98.4	69.9	47.8	116.4	82.7	55.1	116.4	82.7	62.6
300	74.2	54.2	29.1	82.9	58.9	38.6	106.3	75.1	51.2	125.7	89.3	58.4	125.7	89.3	65.7

ANCHOR <b>M20</b>	Edge C (mm)														
	120			150			200			250			300		
	tension		shear	tension		shear	tension		shear	tension		shear	tension		shear
spacing s1 (mm)	N*Rd,p	N*Rd,c	V*Rrd,c	N*Rd,p	N*Rd,c	V*Rrd,c	N*Rd,p	N*Rd,c	V*Rrd,c	N*Rd,p	N*Rd,c	V*Rrd,c	N*Rd,p	N*Rd,c	V*Rrd,c
100	80.8	51.6	28.9	98.8	60.9	44.0	118.5	70.9	55.5	139.7	81.5	64.6	142.0	92.8	73.5
150	87.4	55.0	32.5	106.9	64.9	48.0	128.2	75.5	59.5	151.2	86.8	68.4	153.6	98.9	77.2
200	94.0	58.4	36.1	115.0	68.9	52.0	137.9	80.1	63.5	162.6	92.1	72.2	165.2	104.9	80.9
250	100.7	61.8	39.7	123.1	72.8	56.0	147.6	84.7	67.4	174.1	97.5	76.0	176.9	111.0	84.6
300	107.3	65.1	43.4	131.2	76.8	60.0	157.3	89.4	71.4	185.6	102.8	79.8	188.5	117.1	88.2
350	113.9	68.5	43.4	139.3	80.8	64.1	167.0	94.0	75.4	197.0	108.1	83.6	200.1	123.2	92.0

ANCHOR <b>M24</b>	Edge C (mm)														
	120			150			200			250			350		
	tension		shear	tension		shear	tension		shear	tension		shear	tension		shear
spacing s1 (mm)	N*Rd,p	N*Rd,c	V*Rrd,c	N*Rd,p	N*Rd,c	V*Rrd,c	N*Rd,p	N*Rd,c	V*Rrd,c	N*Rd,p	N*Rd,c	V*Rrd,c	N*Rd,p	N*Rd,c	V*Rrd,c
120	117.8	67.1	39.7	130.3	72.7	49.7	152.5	82.5	67.5	176.2	92.8	77.6	209.4	115.1	97.6
150	122.5	69.2	42.3	135.5	75.0	52.3	158.6	85.0	70.3	183.3	95.7	80.2	217.8	118.6	100.1
200	130.3	73.6	46.4	144.2	78.7	56.6	168.7	89.3	75.0	195.0	100.4	84.7	231.8	124.6	104.2
250	138.2	76.1	50.5	152.9	82.4	61.0	178.9	93.5	79.7	206.7	105.2	89.2	245.7	130.5	108.4
300	146.0	79.5	54.7	161.6	86.2	65.3	189.0	97.7	84.3	218.5	110.0	93.6	259.7	136.4	112.6
350	153.9	83.0	58.8	170.3	89.9	69.7	199.2	102.0	89.0	230.2	114.7	98.1	273.7	142.3	116.8

## Four anchors

**Table 2:** One edge influence – non cracked concrete

Design Data:  $f_{c,cyl}=32$  MPa

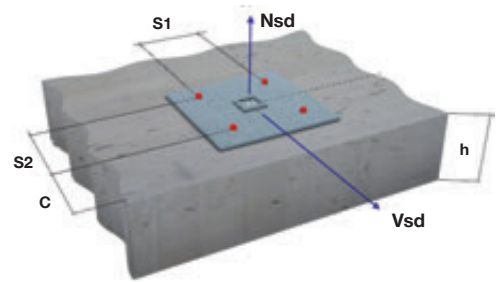

Anchor size	M8	M10	M12	M16	M20	M24
Typical embedment depth $h_{ef}$ [mm]	80	90	110	125	170	210
Base material thickness $h$ [mm]	110	120	150	200	250	300

ANCHOR <b>M8</b>	Edge C (mm)														
	40			80			100			150			200		
	tension		shear	tension		shear	tension		shear	tension		shear	tension		shear
spacing $s1=s2$ (mm)	$N^*_{Rd,p}$	$N^*_{Rd,c}$	$V^*_{Rd,c}$	$N^*_{Rd,p}$	$N^*_{Rd,c}$	$V^*_{Rd,c}$	$N^*_{Rd,p}$	$N^*_{Rd,c}$	$V^*_{Rd,c}$	$N^*_{Rd,p}$	$N^*_{Rd,c}$	$V^*_{Rd,c}$	$N^*_{Rd,p}$	$N^*_{Rd,c}$	$V^*_{Rd,c}$
40	19.1	16.1	12.6	25.8	20.4	17.7	29.5	22.7	19.9	33.4	29.0	25.4	33.4	31.7	30.9
80	25.5	20.6	15.8	33.5	25.6	23.8	37.9	28.3	26.0	42.6	35.6	31.4	42.6	38.7	36.8
100	29.1	23.1	17.2	37.7	28.5	26.8	42.5	31.3	29.0	47.5	39.2	34.4	47.5	42.5	39.7
120	32.8	25.7	18.8	42.2	31.4	29.8	47.3	34.5	32.0	52.8	42.9	37.3	52.8	46.5	42.6
150	38.8	29.9	18.8	49.3	36.2	34.3	55.1	39.6	36.4	61.1	48.8	41.7	61.1	52.7	47.0
200	49.9	37.5	18.8	62.3	44.9	41.2	69.1	48.9	43.7	76.2	59.5	49.0	76.2	64.1	54.2

ANCHOR <b>M10</b>	Edge C (mm)														
	50			80			100			150			200		
	tension		shear	tension		shear	tension		shear	tension		shear	tension		shear
spacing $s1=s2$ (mm)	$N^*_{Rd,p}$	$N^*_{Rd,c}$	$V^*_{Rd,c}$	$N^*_{Rd,p}$	$N^*_{Rd,c}$	$V^*_{Rd,c}$	$N^*_{Rd,p}$	$N^*_{Rd,c}$	$V^*_{Rd,c}$	$N^*_{Rd,p}$	$N^*_{Rd,c}$	$V^*_{Rd,c}$	$N^*_{Rd,p}$	$N^*_{Rd,c}$	$V^*_{Rd,c}$
50	26.3	19.9	17.4	32.1	23.2	21.0	36.2	25.5	23.4	44.1	31.8	29.3	44.1	38.4	35.1
100	36.9	25.9	22.6	44.1	29.8	29.2	49.3	32.5	31.5	59.0	39.8	37.2	59.0	47.5	43.0
150	49.2	32.6	27.0	58.0	37.1	37.2	64.3	40.2	39.4	76.0	48.7	45.1	76.0	57.6	50.7
200	63.3	40.0	27.0	73.8	45.2	45.0	81.3	48.8	47.2	95.2	58.5	52.8	95.2	68.6	58.4
250	79.1	48.2	27.0	91.5	54.1	49.6	100.2	58.2	54.8	116.5	69.2	60.5	116.5	80.6	66.0
300	85.9	57.2	27.0	99.1	63.8	49.9	108.4	68.5	59.8	125.7	80.8	68.0	125.7	93.6	73.5

ANCHOR <b>M12</b>	Edge C (mm)														
	60			80			100			150			200		
	tension		shear	tension		shear	tension		shear	tension		shear	tension		shear
spacing $s1=s2$ (mm)	$N^*_{Rd,p}$	$N^*_{Rd,c}$	$V^*_{Rd,c}$	$N^*_{Rd,p}$	$N^*_{Rd,c}$	$V^*_{Rd,c}$	$N^*_{Rd,p}$	$N^*_{Rd,c}$	$V^*_{Rd,c}$	$N^*_{Rd,p}$	$N^*_{Rd,c}$	$V^*_{Rd,c}$	$N^*_{Rd,p}$	$N^*_{Rd,c}$	$V^*_{Rd,c}$
60	38.1	28.3	24.1	42.6	30.9	26.9	47.3	33.5	29.6	60.2	40.7	36.3	64.4	48.5	42.9
100	47.8	33.8	28.8	53.1	36.7	34.4	58.6	39.7	37.1	73.4	47.6	43.6	78.2	56.3	50.1
150	61.6	41.4	33.8	67.8	44.7	43.4	74.3	48.1	46.2	91.9	57.1	52.7	97.5	66.9	59.1
200	77.1	49.8	37.0	84.4	53.5	49.0	92.0	57.3	55.2	112.3	67.5	61.5	118.9	78.5	67.9
250	94.3	58.9	37.0	102.7	63.0	53.4	111.4	67.3	64.0	134.9	78.7	70.3	142.3	90.9	76.6
300	113.2	68.7	37.0	122.8	73.4	53.4	132.8	78.1	71.4	159.5	90.8	79.0	167.9	104.3	85.2

ANCHOR <b>M16</b>	Edge C (mm)														
	80			100			150			200			250		
	tension		shear	tension		shear	tension		shear	tension		shear	tension		shear
spacing s1=s2 (mm)	N*Rd,p	N*Rd,c	V*Rrd,c	N*Rd,p	N*Rd,c	V*Rrd,c	N*Rd,p	N*Rd,c	V*Rrd,c	N*Rd,p	N*Rd,c	V*Rrd,c	N*Rd,p	N*Rd,c	V*Rrd,c
80	65.0	46.2	37.8	71.4	50.7	40.9	88.7	63.0	48.8	102.8	73.0	56.6	102.8	73.0	64.3
100	71.8	51.0	41.0	78.6	55.8	45.4	97.0	68.9	53.2	112.0	79.6	60.9	112.0	79.6	68.6
150	90.1	64.0	47.2	98.1	69.7	56.3	119.4	84.2	64.0	136.8	97.2	71.5	136.8	97.2	79.1
200	110.5	78.5	53.2	119.7	84.4	64.1	144.2	100.3	74.5	164.1	116.6	82.0	164.1	116.6	89.5
250	133.0	93.2	58.0	143.4	100.0	70.6	171.4	117.9	85.0	193.9	137.2	92.4	193.9	137.8	99.7
300	157.5	109.3	58.0	169.3	116.8	77.2	200.8	136.8	95.3	226.2	158.4	102.6	226.2	160.7	110.0

ANCHOR <b>M20</b>	Edge C (mm)														
	100			150			200			250			300		
	tension		shear	tension		shear	tension		shear	tension		shear	tension		shear
spacing s1=s2 (mm)	N*Rd,p	N*Rd,c	V*Rrd,c	N*Rd,p	N*Rd,c	V*Rrd,c	N*Rd,p	N*Rd,c	V*Rrd,c	N*Rd,p	N*Rd,c	V*Rrd,c	N*Rd,p	N*Rd,c	V*Rrd,c
100	103.6	63.6	55.5	123.2	73.5	64.6	144.5	84.2	73.5	167.4	95.5	82.4	169.8	107.5	91.2
150	124.4	74.1	65.0	146.5	85.1	77.2	170.4	96.8	86.0	196.1	109.2	94.7	198.8	122.3	103.4
200	147.0	85.4	72.2	171.8	97.4	89.6	198.5	110.2	98.2	227.1	123.8	106.8	230.0	138.1	115.5
250	171.5	97.5	79.4	199.1	110.6	101.7	228.7	124.6	110.3	260.3	139.3	118.8	263.6	154.9	127.3
300	197.9	110.4	86.8	228.4	124.6	113.7	261.0	139.8	122.2	295.8	155.8	130.7	299.4	172.7	139.1
350	226.2	124.0	86.8	259.7	139.5	125.6	295.5	155.9	134.0	333.5	173.2	142.4	337.5	191.4	150.8

ANCHOR <b>M24</b>	Edge C (mm)														
	120			150			200			250			350		
	tension		shear	tension		shear	tension		shear	tension		shear	tension		shear
spacing s1=s2 (mm)	N*Rd,p	N*Rd,c	V*Rrd,c	N*Rd,p	N*Rd,c	V*Rrd,c	N*Rd,p	N*Rd,c	V*Rrd,c	N*Rd,p	N*Rd,c	V*Rrd,c	N*Rd,p	N*Rd,c	V*Rrd,c
120	150.2	81.9	75.5	163.9	87.9	81.6	188.0	98.3	91.6	213.6	109.3	101.5	249.3	132.9	121.2
150	164.7	88.2	84.2	179.2	94.5	90.2	204.7	105.4	100.1	231.9	116.9	109.9	269.7	141.6	129.4
200	190.2	99.2	92.8	206.2	106.0	104.2	234.2	117.8	114.0	264.0	130.1	123.7	305.4	156.7	142.9
250	217.6	110.9	101.0	235.1	118.2	118.0	265.7	130.8	127.7	298.2	144.1	137.2	343.3	172.5	156.3
300	246.7	123.2	109.4	265.8	131.1	130.6	299.2	144.6	141.1	334.5	158.8	150.6	383.4	189.1	169.5
350	277.7	136.2	117.6	298.4	144.5	139.5	334.6	159.0	154.5	372.9	174.2	163.9	425.7	206.5	182.6

## Two anchors

**Table 1:** One edge influence – cracked concrete

Design Data:  $f_{c,cyl}=32$  MPa – Cracked Concrete

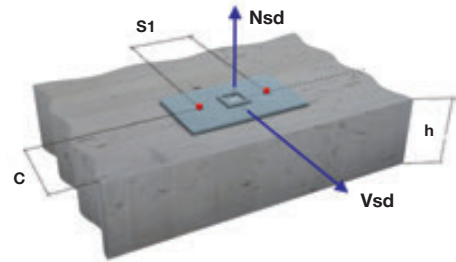
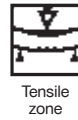

Anchor size	M10	M12	M16	M20	M24
Typical embedment depth $h_{ef}$ [mm]	90	110	125	170	210
Base material thickness $h$ [mm]	120	150	200	250	300

ANCHOR <b>M10</b>	Edge C (mm)														
	50			80			100			150			200		
	tension		shear	tension		shear	tension		shear	tension		shear	tension		shear
spacing $s_1$ (mm)	$N^*_{Rd,p}$	$N^*_{Rd,c}$	$V^*_{Rd,c}$	$N^*_{Rd,p}$	$N^*_{Rd,c}$	$V^*_{Rd,c}$	$N^*_{Rd,p}$	$N^*_{Rd,c}$	$V^*_{Rd,c}$	$N^*_{Rd,p}$	$N^*_{Rd,c}$	$V^*_{Rd,c}$	$N^*_{Rd,p}$	$N^*_{Rd,c}$	$V^*_{Rd,c}$
50	7.3	11.8	6.4	9.1	14.0	10.6	10.5	15.6	12.4	13.1	19.8	16.6	13.1	24.3	20.8
100	8.0	13.1	8.0	10.1	15.6	12.5	11.6	17.3	14.1	14.4	22.0	18.5	14.4	27.1	22.4
150	8.8	14.5	9.6	11.0	17.2	14.3	12.7	19.1	15.9	15.8	24.3	19.9	15.8	29.8	24.0
200	9.5	15.8	9.6	11.9	18.7	16.2	13.7	20.8	17.7	17.1	26.5	21.6	17.1	32.5	25.5
250	10.2	17.1	9.6	12.8	20.3	17.6	14.7	22.6	19.4	18.4	28.7	23.2	18.4	35.2	27.1
300	10.5	18.4	9.6	13.2	21.9	17.6	15.1	24.3	21.2	18.9	30.9	24.9	18.9	39.0	28.7

ANCHOR <b>M12</b>	Edge C (mm)														
	60			80			100			150			200		
	tension		shear	tension		shear	tension		shear	tension		shear	tension		shear
spacing $s_1$ (mm)	$N^*_{Rd,p}$	$N^*_{Rd,c}$	$V^*_{Rd,c}$	$N^*_{Rd,p}$	$N^*_{Rd,c}$	$V^*_{Rd,c}$	$N^*_{Rd,p}$	$N^*_{Rd,c}$	$V^*_{Rd,c}$	$N^*_{Rd,p}$	$N^*_{Rd,c}$	$V^*_{Rd,c}$	$N^*_{Rd,p}$	$N^*_{Rd,c}$	$V^*_{Rd,c}$
60	13.4	16.8	8.7	15.3	18.5	11.8	17.3	20.3	15.2	22.6	25.1	20.0	24.4	30.4	24.8
100	14.5	18.0	10.2	16.5	19.9	13.4	18.6	21.8	16.9	24.4	27.0	21.6	26.3	32.6	26.3
150	15.8	19.6	12.0	18.0	21.6	15.4	20.3	23.7	19.0	26.6	29.3	23.6	28.6	35.5	28.2
200	17.1	21.2	13.1	19.4	23.4	17.4	21.9	25.6	21.1	28.7	31.7	25.5	31.0	38.4	30.0
250	18.4	22.8	13.1	20.9	25.1	18.9	23.6	27.5	23.2	30.9	34.1	27.5	33.2	41.2	31.9
300	19.6	24.3	13.1	22.3	26.8	18.9	25.2	29.4	25.3	33.0	36.4	29.4	35.5	44.1	33.8

ANCHOR <b>M16</b>	Edge C (mm)														
	80			100			150			200			250		
	tension		shear	tension		shear	tension		shear	tension		shear	tension		shear
spacing $s_1$ (mm)	$N^*_{Rd,p}$	$N^*_{Rd,c}$	$V^*_{Rd,c}$	$N^*_{Rd,p}$	$N^*_{Rd,c}$	$V^*_{Rd,c}$	$N^*_{Rd,p}$	$N^*_{Rd,c}$	$V^*_{Rd,c}$	$N^*_{Rd,p}$	$N^*_{Rd,c}$	$V^*_{Rd,c}$	$N^*_{Rd,p}$	$N^*_{Rd,c}$	$V^*_{Rd,c}$
80	21.4	25.3	13.7	23.8	28.3	17.3	30.6	36.3	25.6	36.2	42.9	31.3	36.2	42.9	36.8
100	22.2	26.5	14.6	24.7	29.5	18.2	31.7	37.9	26.6	37.5	44.8	32.2	37.5	44.8	37.7
150	24.2	29.2	16.7	27.0	32.6	20.5	34.6	41.9	29.0	40.9	49.5	34.5	40.9	49.5	39.9
200	26.1	32.0	18.9	29.2	35.7	22.8	37.4	45.9	31.4	44.3	54.2	36.8	44.3	54.2	42.1
250	28.1	34.8	20.6	31.4	38.9	25.0	40.3	49.9	33.9	47.6	58.9	39.1	47.6	58.9	44.3
300	30.1	37.6	20.6	33.6	42.0	27.3	43.1	53.5	36.3	50.9	63.6	41.4	50.9	63.6	46.6

ANCHOR <b>M20</b>	Edge C (mm)														
	100			150			200			250			300		
	tension		shear	tension		shear	tension		shear	tension		shear	tension		shear
spacing s1 (mm)	N*Rd,p	N*Rd,c	V*Rrd,c	N*Rd,p	N*Rd,c	V*Rrd,c	N*Rd,p	N*Rd,c	V*Rrd,c	N*Rd,p	N*Rd,c	V*Rrd,c	N*Rd,p	N*Rd,c	V*Rrd,c
100	34.0	36.8	20.5	41.6	43.4	31.2	49.8	50.5	39.4	58.8	58.1	45.8	59.7	66.1	52.1
150	36.5	39.2	23.1	44.6	46.2	34.0	53.5	53.8	42.2	63.1	61.9	48.5	64.1	70.5	54.7
200	38.9	41.6	25.6	47.6	49.1	36.9	57.1	57.1	45.0	67.3	65.7	51.1	68.4	74.8	57.3
250	41.4	44.0	28.2	50.6	51.9	39.7	60.7	60.4	47.8	71.6	69.5	53.8	72.7	79.1	60.0
300	43.8	46.4	30.7	53.6	54.8	42.6	64.3	63.7	50.6	75.8	73.3	56.5	77.0	83.5	62.5
350	46.3	48.8	30.7	56.6	57.6	45.4	67.9	67.0	53.4	80.1	77.1	59.2	81.3	87.8	65.1

ANCHOR <b>M24</b>	Edge C (mm)														
	120			150			200			250			350		
	tension		shear	tension		shear	tension		shear	tension		shear	tension		shear
spacing s1 (mm)	N*Rd,p	N*Rd,c	V*Rrd,c	N*Rd,p	N*Rd,c	V*Rrd,c	N*Rd,p	N*Rd,c	V*Rrd,c	N*Rd,p	N*Rd,c	V*Rrd,c	N*Rd,p	N*Rd,c	V*Rrd,c
120	48.5	47.8	28.2	53.7	51.8	35.2	62.8	58.8	47.8	72.6	66.1	55.0	86.3	82.0	69.1
150	50.3	49.3	29.9	55.7	53.4	37.0	65.2	60.6	49.8	75.3	68.2	56.9	89.5	84.6	70.9
200	53.4	51.8	32.9	59.0	56.1	40.1	69.1	63.6	53.1	78.9	71.6	60.0	94.9	88.8	73.9
250	56.4	54.2	35.8	62.4	58.8	43.2	73.0	66.7	56.4	84.4	75.0	63.2	100.3	93.0	76.8
300	59.4	56.7	38.8	65.7	61.4	46.3	76.9	69.7	59.8	88.9	78.4	66.3	105.6	97.2	79.8
350	62.4	59.2	41.7	69.0	64.1	49.4	80.8	72.7	63.1	93.4	81.8	69.5	111.0	101.5	82.7

## Four anchors

**Table 2:** One edge influence – cracked concrete

Design Data:  $f_{c,cyl}=32$  MPa– Cracked Concrete

Anchor size	M10	M12	M16	M20	M24
Typical embedment depth $h_{ef}$ [mm]	90	110	125	170	210
Base material thickness $h$ [mm]	120	150	200	250	300



Tensile zone

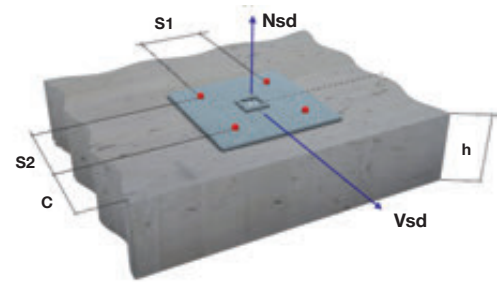

ANCHOR <b>M10</b>	Edge C (mm)														
	50			80			100			150			200		
	tension		shear	tension		shear	tension		shear	tension		shear	tension		shear
spacing $s1=s2$ (mm)	$N^*_{Rd,p}$	$N^*_{Rd,c}$	$V^*_{Rd,c}$	$N^*_{Rd,p}$	$N^*_{Rd,c}$	$V^*_{Rd,c}$	$N^*_{Rd,p}$	$N^*_{Rd,c}$	$V^*_{Rd,c}$	$N^*_{Rd,p}$	$N^*_{Rd,c}$	$V^*_{Rd,c}$	$N^*_{Rd,p}$	$N^*_{Rd,c}$	$V^*_{Rd,c}$
50	11.1	14.2	12.4	13.5	16.5	14.9	15.3	18.2	16.6	18.6	22.7	20.8	18.6	27.4	24.9
100	14.1	18.4	16.0	16.9	21.2	20.7	18.9	23.2	22.4	22.6	28.4	26.4	22.6	33.9	30.4
150	17.4	23.2	19.1	20.6	26.4	26.4	22.8	28.7	28.0	26.9	34.7	32.0	26.9	41.1	35.9
200	20.9	28.5	19.1	24.3	32.2	31.9	26.8	34.8	33.5	31.4	41.7	37.4	31.4	48.9	41.4
250	24.4	34.4	19.1	28.2	38.6	35.2	30.9	41.5	38.8	35.9	49.3	42.9	35.9	57.5	46.8
300	25.8	40.8	19.1	29.7	45.5	35.2	32.5	48.8	42.4	37.7	57.6	48.2	37.7	66.7	52.1

ANCHOR <b>M12</b>	Edge C (mm)														
	60			80			100			150			200		
	tension		shear	tension		shear	tension		shear	tension		shear	tension		shear
spacing $s1=s2$ (mm)	$N^*_{Rd,p}$	$N^*_{Rd,c}$	$V^*_{Rd,c}$	$N^*_{Rd,p}$	$N^*_{Rd,c}$	$V^*_{Rd,c}$	$N^*_{Rd,p}$	$N^*_{Rd,c}$	$V^*_{Rd,c}$	$N^*_{Rd,p}$	$N^*_{Rd,c}$	$V^*_{Rd,c}$	$N^*_{Rd,p}$	$N^*_{Rd,c}$	$V^*_{Rd,c}$
60	19.6	20.2	17.1	21.9	22.0	19.1	24.4	23.9	21.0	31.0	29.0	25.7	33.1	34.6	30.4
100	23.4	24.1	20.4	26.0	26.2	24.4	28.7	28.3	26.3	36.0	34.0	30.9	38.3	40.1	35.6
150	28.7	29.5	24.0	31.6	31.9	30.8	34.6	34.3	32.8	42.7	40.7	37.3	45.4	47.7	41.9
200	34.3	35.5	26.2	37.5	38.1	34.7	40.9	40.9	39.1	49.9	48.1	43.6	52.8	55.9	48.1
250	40.2	42.0	26.2	43.8	44.9	37.9	47.5	48.0	45.4	57.5	56.1	49.8	60.6	64.8	54.3
300	46.3	49.0	26.2	50.3	52.3	37.9	54.4	55.7	50.6	65.3	64.7	56.0	68.7	74.4	60.4

ANCHOR <b>M16</b>	Edge C (mm)														
	80			100			150			200			250		
	tension		shear	tension		shear	tension		shear	tension		shear	tension		shear
spacing $s1=s2$ (mm)	$N^*_{Rd,p}$	$N^*_{Rd,c}$	$V^*_{Rd,c}$	$N^*_{Rd,p}$	$N^*_{Rd,c}$	$V^*_{Rd,c}$	$N^*_{Rd,p}$	$N^*_{Rd,c}$	$V^*_{Rd,c}$	$N^*_{Rd,p}$	$N^*_{Rd,c}$	$V^*_{Rd,c}$	$N^*_{Rd,p}$	$N^*_{Rd,c}$	$V^*_{Rd,c}$
80	30.2	34.3	26.8	33.2	37.4	29.0	41.2	44.9	34.6	47.8	52.0	40.1	47.8	52.0	45.6
100	32.9	36.3	29.2	36.0	39.8	32.2	44.5	49.1	37.7	51.3	56.7	43.2	51.3	56.7	48.6
150	40.0	45.6	33.5	43.6	49.7	39.9	53.1	60.0	45.3	60.8	69.3	50.7	60.8	69.3	56.0
200	47.8	55.9	37.7	51.8	60.2	45.5	62.4	71.5	52.8	71.0	83.1	58.1	71.0	83.1	63.4
250	56.1	66.5	41.2	60.5	71.3	50.1	72.3	84.0	60.2	81.9	97.8	65.4	81.9	98.2	70.7
300	65.0	77.9	41.2	69.9	83.3	54.6	82.9	97.5	67.5	93.4	112.9	72.7	93.4	114.6	77.9

ANCHOR <b>M20</b>	Edge C (mm)														
	100			150			200			250			300		
	tension		shear	tension		shear	tension		shear	tension		shear	tension		shear
spacing s1=s2 (mm)	N*Rd,p	N*Rd,c	V*Rd,c	N*Rd,p	N*Rd,c	V*Rd,c	N*Rd,p	N*Rd,c	V*Rd,c	N*Rd,p	N*Rd,c	V*Rd,c	N*Rd,p	N*Rd,c	V*Rd,c
100	46.6	45.3	39.4	55.5	52.4	45.8	65.0	60.0	52.1	75.4	68.1	58.4	76.4	76.6	64.6
150	54.9	52.8	46.1	64.6	60.6	54.7	75.2	69.0	60.9	86.5	77.8	67.1	87.7	87.2	73.3
200	63.8	60.9	51.2	74.5	69.5	63.5	86.1	78.6	69.6	98.5	88.3	75.7	99.8	98.5	81.8
250	73.3	69.5	56.4	85.0	78.9	72.1	97.6	88.8	78.2	111.1	99.3	84.2	112.6	110.4	90.2
300	83.3	78.7	61.5	96.1	88.9	80.6	109.9	99.7	86.6	124.5	111.1	92.6	126.0	123.1	98.5
350	94.0	88.4	61.5	107.9	99.4	89.0	122.7	111.1	95.0	138.6	123.4	100.9	140.2	136.4	106.8

ANCHOR <b>M24</b>	Edge C (mm)														
	120			150			200			250			350		
	tension		shear	tension		shear	tension		shear	tension		shear	tension		shear
spacing s1=s2 (mm)	N*Rd,p	N*Rd,c	V*Rd,c	N*Rd,p	N*Rd,c	V*Rd,c	N*Rd,p	N*Rd,c	V*Rd,c	N*Rd,p	N*Rd,c	V*Rd,c	N*Rd,p	N*Rd,c	V*Rd,c
120	64.5	58.4	53.5	70.4	62.6	57.8	80.7	70.1	64.9	91.7	77.9	72.0	107.1	94.7	85.9
150	70.3	62.9	59.7	76.5	67.3	63.9	87.4	75.1	70.9	99.0	83.3	77.9	115.1	100.9	91.7
200	80.4	70.8	65.8	87.2	75.6	73.9	99.0	84.0	80.8	111.6	92.8	87.6	129.1	111.7	101.2
250	91.2	79.1	71.6	98.6	84.3	83.6	111.4	93.3	90.4	125.1	102.7	97.2	143.9	123.0	110.7
300	102.7	87.9	77.5	110.6	93.4	92.6	124.5	103.1	100.0	139.2	113.2	106.7	159.6	134.8	120.1
350	114.8	97.1	83.4	123.3	103.0	98.8	138.3	113.4	109.5	154.1	124.2	116.1	176.0	147.2	129.4



## Materials

### Mechanical properties of HIT-V

Anchor size			M8	M10	M12	M16	M20	M24	M27	M30
Nominal tensile strength $f_{uk}$	HIT-V 5.8	[N/mm <sup>2</sup> ]	500	500	500	500	500	500	500	500
	HIT-V 8.8	[N/mm <sup>2</sup> ]	800	800	800	800	800	800	800	800
	HIT-V-R	[N/mm <sup>2</sup> ]	700	700	700	700	700	700	500	500
	HIT-V-HCR	[N/mm <sup>2</sup> ]	800	800	800	800	800	700	700	700
Yield strength $f_{yk}$	HIT-V 5.8	[N/mm <sup>2</sup> ]	400	400	400	400	400	400	400	400
	HIT-V 8.8	[N/mm <sup>2</sup> ]	640	640	640	640	640	640	640	640
	HIT-V-R	[N/mm <sup>2</sup> ]	450	450	450	450	450	450	210	210
	HIT-V-HCR	[N/mm <sup>2</sup> ]	600	600	600	600	600	400	400	400
Stressed cross-section $A_s$	HIT-V	[mm <sup>2</sup> ]	36.6	58.0	84.3	157	245	353	459	561
Moment of resistance W	HIT-V	[mm <sup>3</sup> ]	31.2	62.3	109	277	541	935	1387	1874

### Material quality

Part	Material
Threaded rod HIT-V(F)	Strength class 5.8, $A_s > 8\%$ ductile steel galvanized $\geq 5 \mu\text{m}$ , (F) hot dipped galvanized $\geq 45 \mu\text{m}$ ,
Threaded rod HIT-V(F)	Strength class 8.8, $A_s > 8\%$ ductile steel galvanized $\geq 5 \mu\text{m}$ , (F) hot dipped galvanized $\geq 45 \mu\text{m}$ ,
Threaded rod HIT-V-R	Stainless steel grade A4, $A_s > 8\%$ ductile strength class 70 for M24 and class 50 for M27 to M30, 1.4401; 1.4404; 1.4578; 1.4571; 1.4439; 1.4362
Threaded rod HIT-V-HCR	High corrosion resistant steel, 1.4529; 1.4565 strength M20: $R_m = 800 \text{ N/mm}^2$ , $R_{p0.2} = 640 \text{ N/mm}^2$ , $A_s > 8\%$ ductile M24 to M30: $R_m = 700 \text{ N/mm}^2$ , $R_{p0.2} = 400 \text{ N/mm}^2$ , $A_s > 8\%$ ductile
Washer ISO 7089	Steel galvanized, hot dipped galvanized
	Stainless steel, 1.4401; 1.4404; 1.4578; 1.4571; 1.4439; 1.4362
	High corrosion resistant steel, 1.4529; 1.4565
Nut EN ISO 4032	Strength class 8, steel galvanized $\geq 5 \mu\text{m}$ , hot dipped galvanized $\geq 45 \mu\text{m}$
	Strength class 70, stainless steel grade A4, 1.4401; 1.4404; 1.4578; 1.4571; 1.4439; 1.4362
	Strength class 70, high corrosion resistant steel, 1.4529; 1.4565

### Anchor dimensions

Anchor size	M8	M10	M12	M16	M20	M24	M27	M30
Anchor rod HIT-V, HIT-V-R, HIT-V-HCR	Anchor rods HIT-V (-R / -HCR) are available in variable length							

### Setting

#### Installation equipment

Anchor size	M8	M10	M12	M16	M20	M24	M27	M30
Rotary hammer	TE 2 – TE 30				TE 40 – TE 70			
Other tools	compressed air gun or blow out pump, set of cleaning brushes, dispenser							

## Setting instructions

### Bore hole drilling

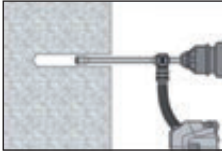

Drill hole to the required embedment depth with an appropriately sized Hilti TE-CD or TE-YD hollow drill bit with Hilti vacuum attachment. This drilling method properly cleans the borehole and removes dust while drilling. After drilling is complete, proceed to the "injection preparation" step in the instructions for use

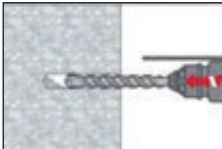

Drill Hole to the required embedment depth with a hammer drill set in rotation-hammer mode using an appropriately sized carbide drill bit.

### Bore hole cleaning **Just before setting an anchor, the bore hole must be free of dust and debris.**

#### a) Manual Cleaning (MC) non-cracked concrete only for bore hole diameters $d_0 \leq 20\text{mm}$ and bore hole depth $h_0 \leq 10d$

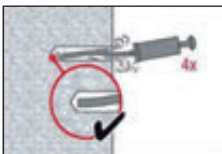

The Hilti manual pump may be used for blowing out bore holes up to diameters  $d_0 \leq 20\text{ mm}$  and embedment depths up to  $h_{ef} \leq 10d$ . Blow out at least 4 times from the back of the bore hole until return air stream is free of noticeable dust

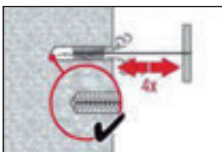

Brush 4 times with the specified brush size by inserting the steel brush Hilti HIT-RB to the back of the hole (if needed with extension) in a twisting motion and removing it. The brush must produce natural resistance as it enters the bore hole -- if not the brush is too small and must be replaced with the proper brush diameter.

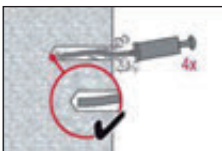

Blow out again with manual pump at least 4 times until return air stream is free of noticeable dust.

#### b) Compressed air cleaning (CAC) for all bore hole diameters $d_0$ and all bore hole depth $h_0$



Blow 2 times from the back of the hole (if needed with nozzle extension) over the hole length with oil-free compressed air (min. 6 bar at  $6\text{ m}^3/\text{h}$ ) until return air stream is free of noticeable dust. Bore hole diameter  $\geq 32\text{ mm}$  the compressor must supply a minimum air flow of  $140\text{ m}^3/\text{hour}$ .

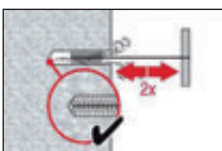

Brush 2 times with the specified brush size (brush  $\text{Ø} \geq$  bore hole  $\text{Ø}$ , see Table 6) by inserting the steel brush Hilti HIT-RB to the back of the hole (if needed with extension) in a twisting motion and removing it. The brush must produce natural resistance as it enters the bore hole -- if not the brush is too small and must be replaced with the proper brush diameter.



Blow again with compressed air 2 times until return air stream is free of noticeable dust.

## Setting instructions

### Injection preparation

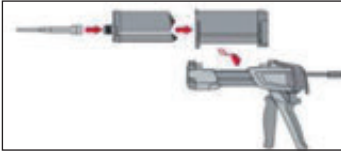

Tightly attach new Hilti mixing nozzle HIT-RE-M to foil pack manifold (snug fit). Do not modify the mixing nozzle. Observe the instruction for use of the dispenser. Check foil pack holder for proper function. Do not use damaged foil packs / holders. Swing foil pack holder with foil pack into HIT dispenser.

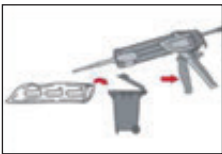

Discard initial adhesive. The foil pack opens automatically as dispensing is initiated. Depending on the size of the foil pack an initial amount of adhesive has to be discarded.

Discard quantities are:

- 2 strokes for 330 ml foil pack,
- 3 strokes for 500 ml foil pack,
- 4 strokes for 500 ml foil pack  $\leq 5^{\circ}\text{C}$ .

### Inject adhesive from the back of the borehole without forming air voids

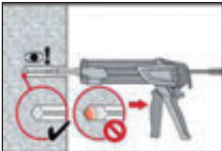

Inject the adhesive starting at the back of the hole, slowly withdrawing the mixer with each trigger pull. Fill holes approximately 2/3 full, or as required to ensure that the annular gap between the anchor and the concrete is completely filled with adhesive along the embedment length.

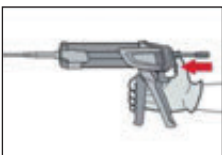

After injection is completed, depressurise the dispenser by pressing the release trigger. This will prevent further adhesive discharge from the mixer.

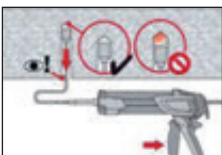

Overhead installation and/or installation with embedment depth  $h_{ef} > 250\text{mm}$ . For overhead installation the injection is only possible with the aid of extensions and piston plugs. Assemble HIT-RE-M mixer, extension(s) and appropriately sized piston plug. Insert piston plug to back of the hole and inject adhesive. During injection the piston plug will be naturally extruded out of the bore hole by the adhesive pressure.

### Setting the element

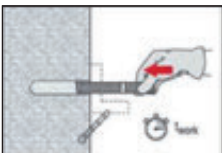

Before use, verify that the element is dry and free of oil and other contaminants.  
Mark and set element to the required embedment depth until working time  $t_{work}$  has elapsed

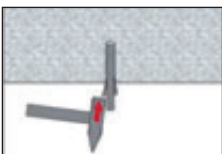

For overhead installation use piston plugs and fix embedded parts with e.g. wedges

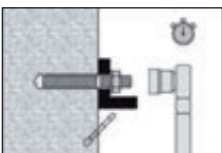

Loading the anchor:  
After required curing time  $t_{cure}$  the anchor can be loaded.  
The applied installation torque shall not exceed  $T_{max}$ .

For detailed information on installation see instruction for use given with the package of the product.

## Working time, curing time

Temperature of the base material $T_{BM}$	Working time in which anchor can be inserted and adjusted $t_{work}$	Curing time before anchor can be loaded $t_{cure}$
-10 °C to -5 °C	3 hour	20 hour
-4 °C to 0 °C	2 hour	7 hour
1 °C to 5 °C	1 hour	3 hour
6 °C to 10 °C	40 min	2 hour
11 °C to 20 °C	15 min	1 hour
21 °C to 30 °C	9 min	1 hour
31 °C to 40 °C	6 min	1 hour

## Setting details

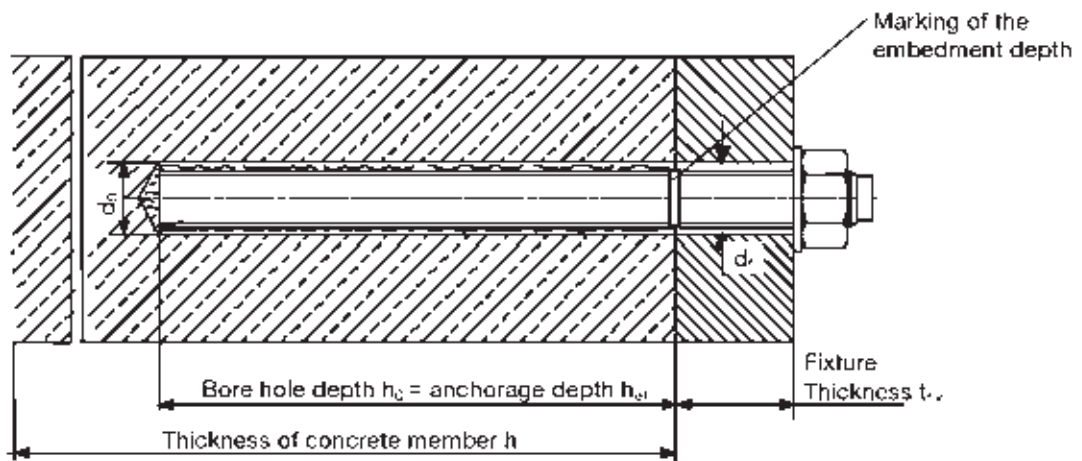



Anchor size			M8	M10	M12	M16	M20	M24
Nominal diameter of drill bit	$d_0$	[mm]	10	12	14	18	22	28
Effective embedment and drill hole depth range a) for HIT-V	$h_{ef,min}$	[mm]	60	60	70	80	90	96
	$h_{ef,max}$	[mm]	160	200	240	320	400	480
Effective anchorage and drill hole depth for HAS	$h_{ef}$	[mm]	80	90	110	125	170	210
Minimum base material thickness	$h_{min}$	[mm]	$h_{ef} + 30 \text{ mm} \geq 100 \text{ mm}$			$h_{ef} + 2 d_0$		
Diameter of clearance hole in the fixture	$d_f$	[mm]	9	12	14	18	22	26
Torque moment	$T_{max}^{b)}$	[Nm]	10	20	40	80	150	200
Minimum spacing	$s_{min}$	[mm]	40	50	60	80	100	120
Minimum edge distance	$c_{min}$	[mm]	40	50	60	80	100	120

a) Embedment depth range:  $h_{ef,min} \leq h_{ef} \leq h_{ef,max}$

b) Maximum recommended torque moment to avoid splitting failure during installation with minimum spacing and/or edge distance

## Hilti HIT-HY 200 with HIS-(R)N

Injection Mortar System	Benefits
 <p>Hilti HIT-HY 200-R 500 ml foil pack (also available as 330 ml foil pack)</p>  <p>Static mixer</p>  <p>Internal threaded sleeve HIS-N HIS-RN</p>	<ul style="list-style-type: none"> <li>■ Suitable for non-cracked and cracked concrete C 20/25 to C 50/60</li> <li>■ Suitable for dry and water saturated concrete</li> <li>■ High loading capacity, excellent handling and fast curing</li> <li>■ Small edge distance and anchor spacing possible</li> <li>■ Corrosion resistant</li> <li>■ In service temperature range up to 120°C short term/72°C long term</li> <li>■ Manual cleaning for anchor size M8 and M10</li> </ul>



Concrete



Tensile zone



Small edge distance & spacing



Corrosion resistance



European Technical Approval



CE conformity



PROFIS anchor design software



SAFEset approved automatic cleaning

### Approvals / certificates

Description	Authority / Laboratory	No. / date of issue
European technical approval <sup>a)</sup>	DIBt, Berlin	ETA-12/0084 / 2013-06-20 (Hilti HIT-HY 200-R)

a) All data given in this section according ETA-11/0493 and ETA-12/0084, issue 2013-06-20.

### Service temperature range

Hilti HIT-HY 200 injection mortar may be applied in the temperature ranges given below. An elevated base material temperature may lead to a reduction of the design bond resistance.

Temperature range	Base material temperature	Maximum long term base material temperature	Maximum short term base material temperature
Temperature range I	-40 °C to +40 °C	+24 °C	+40 °C
Temperature range II	-40 °C to +80 °C	+50 °C	+80 °C
Temperature range III	-40 °C to +120 °C	+72 °C	+120 °C

#### Max short term base material temperature

Short-term elevated base material temperatures are those that occur over brief intervals, e.g. as a result of diurnal cycling.

#### Max long term base material temperature

Long-term elevated base material temperatures are roughly constant over significant periods of time

## Design process for typical anchor layouts

The design values in the tables are obtained from Profis V2.2.1 in compliance with the design method according to EOTA TR 029. Design resistance according to data given in ETA-12/0084, issue 2013-06-20.

- Influence of concrete strength
- Influence of edge distance
- Influence of spacing

The design method is based on the following simplification:

- No different loads are acting on individual anchors (no eccentricity)

The values are valid for the anchor configuration.

For more complex fastening applications please use the anchor design software PROFIS Anchor.

### STEP 1: TENSION LOADING

The design tensile resistance  $N_{Rd}$  is the lower of:

- Combined pull-out and concrete cone resistance

$$N_{Rd,p} = f_{B,p} \cdot N^*_{Rd,p}$$

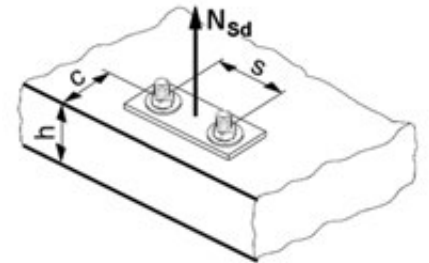

$N^*_{Rd,p}$  is obtained from the relevant design tables

$f_{B,p}$  influence of concrete strength on combined pull-out and concrete cone resistance

Concrete Strengths $f'_{c,cyl}$ (MPa)	20	25	32	40	50
$f_{B,p}$	1.00	1.00	1.00	1.00	1.00

- Concrete cone or concrete splitting resistance

$$N_{Rd,c} = f_B \cdot N^*_{Rd,c}$$

$N^*_{Rd,c}$  is obtained from the relevant design tables

$f_B$  influence of concrete strength on concrete cone resistance

Concrete Strengths $f'_{c,cyl}$ (MPa)	20	25	32	40	50
$f_B$	0.79	0.87	1.00	1.11	1.22

- Design steel resistance (tension)  $N_{Rd,s}$

Anchor size			M8	M10	M12	M16	M20
$N_{Rd,s}$	HIS-N	[kN]	17.5	30.7	44.7	80.3	74.1
	HIS-RN	[kN]	13.9	21.9	31.6	58.8	69.2
Bolt	Grade 5.8	[kN]	12.0	19.3	28.0	52.7	82.0
Bolt	Grade 8.8	[kN]	19.3	30.7	44.7	84.0	130.7
Bolt	Grade A 4-70 / 316	[kN]	13.9	21.9	31.6	58.8	92.0

**Note:** Designer needs to check the bolt tensile resistance.

$$N_{Rd} = \min \{ N_{Rd,p}, N_{Rd,c}, N_{Rd,s} \}$$

**CHECK  $N_{Rd} \geq N_{Sd}$**

## STEP 2: SHEAR LOADING

The design shear resistance  $V_{Rd}$  is the lower of:

### ■ Design Concrete Edge Resistance

$$V_{Rd,c} = f_B \cdot V^*_{Rd,c}$$

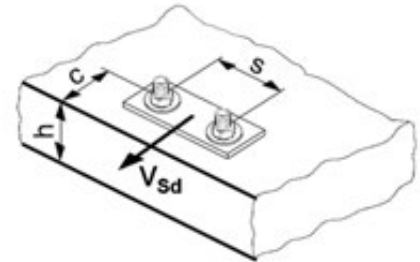

$V^*_{Rd,c}$  is obtained from the relevant design table

### $f_B$ influence of concrete strength

Concrete Strengths $f'_{c,cyl}$ (MPa)	20	25	32	40	50
$f_B$	0.79	0.87	1.00	1.11	1.22

#### Shear load acting parallel to edge:

These tables are for a single free edge only

#### 2 anchors:

For shear loads acting parallel to this edge, the concrete resistance  $V^*_{Rd,c}$  can be multiplied by the factor = 2.5

#### 4 anchors:

For shear loads acting parallel to the edge - the anchor row closest to the edge is checked to resist half the total design load.

To obtain the concrete resistance use the corresponding 2 anchor configuration  $V^*_{Rd,c}$  and multiply by the factor = 2.5

### ■ Design steel resistance (shear): $V_{Rd,s}$

Anchor size			M8	M10	M12	M16	M20
$V_{Rd,s}$	HIS-N	[kN]	10.4	18.4	26.0	39.3	36.7
	HIS-RN	[kN]	8.3	12.8	19.2	35.3	41.5
	Bolt Grade 5.8	[kN]	7.2	12.0	16.8	31.2	48.8
	Bolt Grade 8.8	[kN]	12.0	18.4	27.2	50.4	78.4
	Bolt Grade A 4-70 / 316	[kN]	8.3	12.8	19.2	35.3	55.1

**Note:** Designer needs to check the bolt shear resistance.

$$V_{Rd} = \min \{ V_{Rd,c}, V_{Rd,s} \}$$

**CHECK  $V_{Rd} \geq V_{Sd}$**



**STEP 3: COMBINED TENSION AND SHEAR LOADING**

The following equations must be satisfied:

$$N_{Sd}/N_{Rd} + V_{Sd}/V_{Rd} \leq 1.2$$

and

$$N_{Sd}/N_{Rd} \leq 1, V_{Sd}/V_{Rd} \leq 1$$

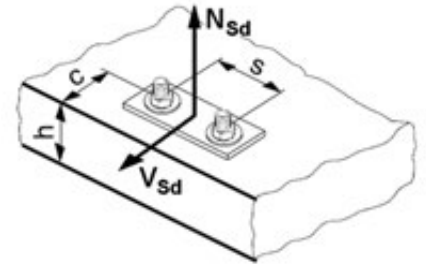

## Precalculated table values – design resistance values

### General:

The following tables provide the total ultimate limit state design resistance for the configurations. All tables are based upon:

- correct setting (See setting instruction)
- non cracked and cracked concrete –  $f_{c,cyl} = 32$  MPa
- temperature range I (see service temperature range)
- base material thickness, as specified in the table
- One typical embedment depth, as specified in the tables

## Basic loading data (for a single anchor) – no edge distance and spacing influence

### Embedment depth and base material thickness for the basic loading data



Anchor size	M8x90	M10x110	M12x125	M16x170	M20x205
Typical embedment depth $h_{ef}$ [mm]	90	110	125	170	205
Base material thickness $h$ [mm]	120	150	200	250	300

## Design resistance: concrete 32 MPa

Anchor size		M8	M10	M12	M16	M20
<b>Non-cracked concrete</b>						
Tensile	Pull-out $N_{Rd,p}$ [kN]	30.6	49.4	69.8	117.6	154.1
	Concrete $N_{Rd,c}$ [kN]	36.4	49.1	59.5	94.4	125.0
Shear	$V_{Rd,s}$ [kN]	Steel governed refer $V_{Rd,s}$ table				
<b>Cracked concrete</b>						
Tensile	Pull-out $N_{Rd,p}$ [kN]	16.5	26.6	37.6	63.3	82.9
	Concrete $N_{Rd,c}$ [kN]	25.9	35.0	42.4	67.3	89.1
Shear	$V_{Rd,s}$ [kN]	Steel governed refer $V_{Rd,s}$ table				

## Basic loading data (for a single anchor) – with minimum edge distance



### Design resistance [kN] - uncracked concrete, 32 Mpa

Anchor size		M8	M10	M12	M16	M20	
Min. edge distance	$c_{min}$ [mm]	40	45	55	65	90	
Min Base thickness	$h_{min}$ [mm]	120	150	200	250	300	
<b>Tensile NRd</b>							
	Pull-out	$N_{Rd,p}^*$ [kN]	15.7	24.6	35.6	57.3	78.4
	Concrete	$N_{Rd,c}^*$ [kN]	16.6	22.1	30.3	45.3	62.9
<b>Shear VRd</b>							
	Shear (without lever arm)	$V_{Rd,c}$	5.3	7.0	9.7	13.7	21.7

## Basic loading data (for a single anchor) – with minimum edge distance

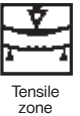
### Design resistance [kN] - cracked concrete, 32 Mpa



Anchor size		M8	M10	M12	M16	M20	
Min. edge distance	$c_{min}$ [mm]	40	45	55	65	90	
Min Base thickness	$h_{min}$ [mm]	120	150	200	250	300	
<b>Tensile NRd</b>							
	Pull-out	$N_{Rd,p}^*$ [kN]	8.4	13.2	19.1	30.8	42.2
	Concrete	$N_{Rd,c}^*$ [kN]	11.8	15.8	21.6	32.3	44.8
<b>Shear VRd</b>							
	Shear (without lever arm)	$V_{Rd,c}$	3.8	4.9	6.9	9.7	15.4

## Two anchors

**Table 1:** One edge influence – non cracked concrete

Design Data:  $f_c=32$  MPa

Anchor size	M8	M10	M12	M16	M20
Min Slab depth	120	150	200	250	300
Embedment Depth	90	110	125	170	205

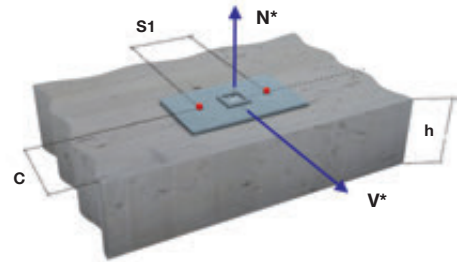

ANCHOR <b>M8</b>	Edge C (mm)														
	40			80			100			150			200		
	tension		shear	tension		shear	tension		shear	tension		shear	tension		shear
spacing s1 (mm)	N <sup>*Rd,p</sup>	N <sup>*Rd,c</sup>	V <sup>*Rrd,c</sup>	N <sup>*Rd,p</sup>	N <sup>*Rd,c</sup>	V <sup>*Rrd,c</sup>	N <sup>*Rd,p</sup>	N <sup>*Rd,c</sup>	V <sup>*Rrd,c</sup>	N <sup>*Rd,p</sup>	N <sup>*Rd,c</sup>	V <sup>*Rrd,c</sup>	N <sup>*Rd,p</sup>	N <sup>*Rd,c</sup>	V <sup>*Rrd,c</sup>
40	19.0	18.3	7.1	26.0	23.1	15.1	29.8	25.7	17.5	37.2	32.6	23.6	37.2	40.0	29.6
80	21.2	20.0	8.9	28.9	25.2	17.2	33.2	28.0	19.6	41.4	35.6	25.6	41.4	43.7	31.5
100	22.2	20.8	9.8	30.4	26.3	18.3	34.9	29.2	20.6	43.5	37.1	26.5	43.5	45.5	32.4
150	24.9	22.9	10.7	34.1	28.9	21.0	39.1	32.1	23.2	48.8	40.9	28.9	48.8	50.1	34.7
200	27.6	25.0	10.7	37.8	31.5	23.7	43.3	35.1	25.8	54.0	44.6	31.4	54.0	54.7	37.0

ANCHOR <b>M10</b>	Edge C (mm)														
	45			80			100			150			200		
	tension		shear	tension		shear	tension		shear	tension		shear	tension		shear
spacing s1 (mm)	N <sup>*Rd,p</sup>	N <sup>*Rd,c</sup>	V <sup>*Rrd,c</sup>	N <sup>*Rd,p</sup>	N <sup>*Rd,c</sup>	V <sup>*Rrd,c</sup>	N <sup>*Rd,p</sup>	N <sup>*Rd,c</sup>	V <sup>*Rrd,c</sup>	N <sup>*Rd,p</sup>	N <sup>*Rd,c</sup>	V <sup>*Rrd,c</sup>	N <sup>*Rd,p</sup>	N <sup>*Rd,c</sup>	V <sup>*Rrd,c</sup>
45	27.9	24.3	9.3	35.3	28.9	16.8	39.8	31.7	21.7	52.1	39.2	28.7	56.2	47.4	35.6
80	30.5	25.9	11.1	38.5	30.8	18.9	43.5	33.8	23.9	57.0	41.9	30.8	61.4	50.6	37.6
100	32.0	26.8	12.1	40.4	32.0	20.1	45.6	35.1	25.1	59.8	43.4	31.9	64.4	52.5	38.7
150	35.8	29.2	13.9	45.1	34.8	23.0	50.9	38.1	28.3	66.7	47.2	34.8	71.9	57.1	41.4
200	39.5	31.5	13.9	49.8	37.5	26.0	56.2	41.2	31.4	73.7	51.0	37.7	79.4	61.7	44.2
250	43.2	33.9	13.9	54.5	40.3	28.3	61.5	44.3	34.6	80.6	54.7	40.6	86.9	66.2	47.0

ANCHOR <b>M12</b>	Edge C (mm)														
	55			80			100			150			200		
	tension		shear	tension		shear	tension		shear	tension		shear	tension		shear
spacing s1 (mm)	N <sup>*Rd,p</sup>	N <sup>*Rd,c</sup>	V <sup>*Rrd,c</sup>	N <sup>*Rd,p</sup>	N <sup>*Rd,c</sup>	V <sup>*Rrd,c</sup>	N <sup>*Rd,p</sup>	N <sup>*Rd,c</sup>	V <sup>*Rrd,c</sup>	N <sup>*Rd,p</sup>	N <sup>*Rd,c</sup>	V <sup>*Rrd,c</sup>	N <sup>*Rd,p</sup>	N <sup>*Rd,c</sup>	V <sup>*Rrd,c</sup>
55	40.8	34.8	12.9	47.3	40.3	18.8	52.7	45.0	23.9	67.7	57.7	35.8	80.0	70.7	44.0
100	45.0	38.4	15.5	52.2	44.5	21.6	58.3	49.7	26.9	74.8	63.1	39.0	88.4	75.4	47.0
150	49.8	42.5	18.5	57.7	49.2	24.8	64.4	54.9	30.2	82.6	69.1	42.6	97.7	83.3	50.4
200	54.5	46.5	19.4	63.2	53.9	28.0	70.5	59.8	33.6	90.5	75.0	46.1	107.0	91.3	53.7
250	59.3	50.5	19.4	68.7	58.4	30.5	76.7	64.5	37.0	98.4	81.0	49.7	116.3	99.1	57.1
300	64.0	54.6	19.4	74.2	62.7	30.5	82.8	69.2	40.3	106.2	86.9	53.2	125.6	106.4	60.5

ANCHOR <b>M16</b>	Edge C (mm)														
	65			100			150			200			250		
	tension		shear	tension		shear	tension		shear	tension		shear	tension		shear
spacing s1 (mm)	N*Rd,p	N*Rd,c	V*Rrd,c	N*Rd,p	N*Rd,c	V*Rrd,c	N*Rd,p	N*Rd,c	V*Rrd,c	N*Rd,p	N*Rd,c	V*Rrd,c	N*Rd,p	N*Rd,c	V*Rrd,c
65	64.6	49.7	18.3	75.4	56.3	27.7	92.3	66.4	43.0	110.6	77.3	54.8	130.5	88.9	64.1
100	68.5	52.1	20.7	80.0	59.0	30.4	97.9	69.6	46.0	117.3	81.0	57.7	138.4	93.2	66.9
150	74.1	55.5	24.2	86.6	62.9	34.2	105.9	74.2	50.1	127.0	86.3	61.8	149.8	99.3	70.8
200	79.7	58.9	27.4	93.2	66.8	38.0	113.9	78.8	54.3	136.6	91.6	66.0	161.1	105.4	74.8
250	85.4	62.3	27.4	99.7	70.6	41.8	121.9	83.3	58.5	146.2	96.9	70.1	172.5	111.5	78.7
300	90.8	65.7	27.4	106.3	74.5	45.6	130.0	87.9	62.7	155.8	102.2	74.2	183.8	117.6	82.6

ANCHOR <b>M20</b>	Edge C (mm)														
	90			150			200			250			300		
	tension		shear	tension		shear	tension		shear	tension		shear	tension		shear
spacing s1 (mm)	N*Rd,p	N*Rd,c	V*Rrd,c	N*Rd,p	N*Rd,c	V*Rrd,c	N*Rd,p	N*Rd,c	V*Rrd,c	N*Rd,p	N*Rd,c	V*Rrd,c	N*Rd,p	N*Rd,c	V*Rrd,c
90	89.9	69.9	28.9	111.2	83.0	48.1	130.4	94.7	65.9	151.1	107.0	76.2	173.2	120.0	86.4
150	97.6	74.6	33.8	120.6	88.6	53.4	141.5	101.0	71.6	164.0	114.2	81.7	187.9	128.1	91.7
200	104.0	78.5	37.8	128.5	93.2	57.8	150.8	106.3	76.4	174.4	120.1	86.2	200.2	134.8	96.1
250	110.3	82.4	41.8	136.4	97.8	62.3	160.0	111.6	81.2	185.4	126.1	90.7	212.5	141.5	100.4
300	116.7	86.3	43.4	144.3	102.5	66.7	169.3	116.9	85.9	196.1	132.1	95.3	224.7	148.2	104.8
350	123.1	90.2	43.4	152.2	107.1	71.2	178.6	122.1	90.7	206.8	138.1	99.8	237.0	154.9	109.1

## Four anchors

**Table 2:** One edge influence – non cracked concrete

Design Data:  $f_c=32$  MPa

Anchor size	M8	M10	M12	M16	M20
Min Slab depth	120	150	200	250	300
Embedment Depth	90	110	125	170	205

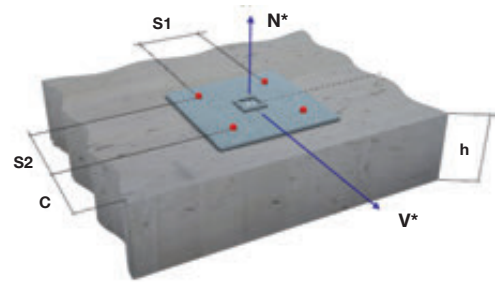

ANCHOR <b>M8</b>	Edge C (mm)														
	40			80			100			150			200		
	tension		shear	tension		shear	tension		shear	tension		shear	tension		shear
spacing $s_1 = s_2$ (mm)	$N^*_{Rd,p}$	$N^*_{Rd,c}$	$V^*_{Rd,c}$	$N^*_{Rd,p}$	$N^*_{Rd,c}$	$V^*_{Rd,c}$	$N^*_{Rd,p}$	$N^*_{Rd,c}$	$V^*_{Rd,c}$	$N^*_{Rd,p}$	$N^*_{Rd,c}$	$V^*_{Rd,c}$	$N^*_{Rd,p}$	$N^*_{Rd,c}$	$V^*_{Rd,c}$
40	25.1	21.4	14.2	33.1	26.4	22.0	37.5	29.1	22.4	45.9	36.4	28.4	45.9	44.1	34.3
80	32.6	26.7	17.8	41.9	32.4	26.8	47.0	35.5	29.1	56.7	43.8	35.0	56.7	52.5	40.8
100	36.6	29.6	19.6	46.7	35.7	30.1	52.2	39.0	32.4	62.5	47.8	38.2	62.5	57.0	44.0
150	47.8	37.4	21.4	59.7	44.5	38.2	66.2	48.3	40.5	78.3	58.5	46.2	78.3	69.1	51.8
200	60.2	46.0	21.4	74.2	54.2	46.1	81.7	58.6	48.4	95.7	70.2	54.0	95.7	82.4	59.6

ANCHOR <b>M10</b>	Edge C (mm)														
	45			80			100			150			200		
	tension		shear	tension		shear	tension		shear	tension		shear	tension		shear
spacing $s_1 = s_2$ (mm)	$N^*_{Rd,p}$	$N^*_{Rd,c}$	$V^*_{Rd,c}$	$N^*_{Rd,p}$	$N^*_{Rd,c}$	$V^*_{Rd,c}$	$N^*_{Rd,p}$	$N^*_{Rd,c}$	$V^*_{Rd,c}$	$N^*_{Rd,p}$	$N^*_{Rd,c}$	$V^*_{Rd,c}$	$N^*_{Rd,p}$	$N^*_{Rd,c}$	$V^*_{Rd,c}$
45	33.9	28.1	18.6	41.7	33.0	25.2	46.5	35.9	28.0	59.6	43.7	35.0	63.8	52.3	41.8
80	42.2	33.3	22.2	51.1	38.7	32.1	56.6	41.9	34.8	71.5	50.5	41.6	76.3	59.9	48.3
100	47.3	36.4	24.2	56.9	42.1	36.0	62.8	45.5	38.7	78.8	54.6	45.4	83.9	64.5	52.0
150	61.3	44.8	27.8	72.7	51.2	45.4	79.7	55.1	48.0	98.5	65.5	54.6	104.6	76.7	61.1
200	77.1	54.0	27.8	90.5	61.3	52.0	98.6	65.7	57.2	120.5	77.3	63.7	127.5	89.9	70.1
250	94.7	64.0	27.8	110.1	72.2	56.7	119.5	77.2	66.2	144.7	90.2	72.6	152.6	104.2	79.0

ANCHOR <b>M12</b>	Edge C (mm)														
	55			80			100			150			200		
	tension		shear	tension		shear	tension		shear	tension		shear	tension		shear
spacing $s_1 = s_2$ (mm)	$N^*_{Rd,p}$	$N^*_{Rd,c}$	$V^*_{Rd,c}$	$N^*_{Rd,p}$	$N^*_{Rd,c}$	$V^*_{Rd,c}$	$N^*_{Rd,p}$	$N^*_{Rd,c}$	$V^*_{Rd,c}$	$N^*_{Rd,p}$	$N^*_{Rd,c}$	$V^*_{Rd,c}$	$N^*_{Rd,p}$	$N^*_{Rd,c}$	$V^*_{Rd,c}$
55	50.0	42.7	25.8	57.0	48.6	33.4	62.8	53.6	36.7	78.7	66.4	44.8	91.7	78.3	52.8
100	63.6	54.3	31.0	71.7	61.0	43.2	78.5	66.2	47.0	96.9	80.4	54.9	111.9	95.5	62.8
150	80.6	67.9	37.0	90.0	75.1	49.6	98.0	81.2	58.2	119.4	97.4	65.9	136.7	115.1	73.6
200	99.5	82.5	38.8	110.4	90.8	56.0	119.6	97.7	67.2	144.1	116.1	76.7	164.0	136.1	84.3
250	120.3	98.5	38.8	132.9	107.9	61.0	143.3	115.7	74.0	171.2	136.4	87.3	193.8	158.8	94.8
300	143.2	115.9	38.8	157.4	126.5	61.0	169.2	135.2	80.6	200.7	158.3	97.8	226.1	183.3	105.2

ANCHOR <b>M16</b>	Edge C (mm)														
	65			100			150			200			250		
	tension		shear	tension		shear	tension		shear	tension		shear	tension		shear
spacing s1= s2 (mm)	N*Rd,p	N*Rd,c	V*Rd,c	N*Rd,p	N*Rd,c	V*Rd,c	N*Rd,p	N*Rd,c	V*Rd,c	N*Rd,p	N*Rd,c	V*Rd,c	N*Rd,p	N*Rd,c	V*Rd,c
65	77.7	57.8	36.6	89.3	64.8	48.0	107.1	75.4	57.6	126.4	86.8	66.9	147.3	98.8	76.1
100	89.9	65.2	41.4	102.6	72.7	57.7	122.0	84.1	66.9	143.1	96.2	76.0	165.8	109.2	85.0
150	108.9	76.5	48.5	123.2	84.7	68.4	145.1	97.3	79.8	168.8	110.7	88.7	194.3	124.9	97.6
200	129.6	88.6	54.8	145.6	97.7	76.0	170.2	111.4	92.4	196.6	126.1	101.2	224.9	141.6	109.9
250	152.0	101.6	54.8	169.9	111.5	83.6	197.2	126.5	104.8	226.5	142.5	113.5	257.8	159.4	122.1
300	176.3	115.4	54.8	196.1	126.2	91.2	226.2	142.6	117.0	258.5	159.9	125.6	293.0	178.2	134.2

ANCHOR <b>M20</b>	Edge C (mm)														
	90			150			200			250			300		
	tension		shear	tension		shear	tension		shear	tension		shear	tension		shear
spacing s1= s2 (mm)	N*Rd,p	N*Rd,c	V*Rd,c	N*Rd,p	N*Rd,c	V*Rd,c	N*Rd,p	N*Rd,c	V*Rd,c	N*Rd,p	N*Rd,c	V*Rd,c	N*Rd,p	N*Rd,c	V*Rd,c
90	110.3	82.7	57.8	133.1	96.5	74.2	153.6	108.8	84.4	175.5	121.8	94.5	198.8	135.4	104.6
150	134.4	97.3	67.6	160.2	112.6	91.7	183.4	126.1	101.6	208.1	140.4	111.5	234.3	155.4	121.4
200	156.3	110.4	75.6	184.7	126.9	105.9	210.2	141.5	115.7	237.3	157.0	125.4	266.1	173.1	135.1
250	179.7	124.2	83.6	211.0	142.1	119.8	238.9	157.8	129.5	268.5	174.4	139.1	299.9	191.8	148.7
300	204.8	138.9	86.8	238.9	158.0	133.5	269.4	175.0	143.1	301.7	192.8	152.6	335.7	211.4	162.1
350	231.5	154.3	86.8	268.6	174.9	142.4	301.7	193.0	156.5	336.7	212.1	166.0	373.6	232.0	175.4



## Two anchors

**Table 1:** One edge influence – cracked concrete

Design Data:  $f_c=32$  MPa

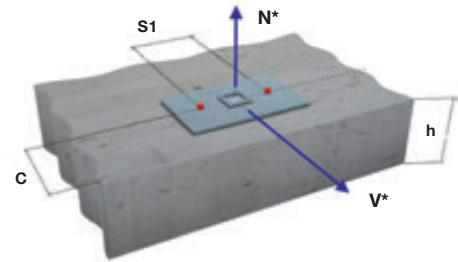
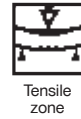

Anchor size	M8	M10	M12	M16	M20
Min Slab depth	120	150	200	250	300
Embedment Depth	90	110	125	170	205

ANCHOR <b>M8</b>	Edge C (mm)														
	40			80			100			150			200		
	tension		shear	tension		shear	tension		shear	tension		shear	tension		shear
spacing s1 (mm)	N <sup>*</sup> Rd,p	N <sup>*</sup> Rd,c	V <sup>*</sup> Rd,c	N <sup>*</sup> Rd,p	N <sup>*</sup> Rd,c	V <sup>*</sup> Rd,c	N <sup>*</sup> Rd,p	N <sup>*</sup> Rd,c	V <sup>*</sup> Rd,c	N <sup>*</sup> Rd,p	N <sup>*</sup> Rd,c	V <sup>*</sup> Rd,c	N <sup>*</sup> Rd,p	N <sup>*</sup> Rd,c	V <sup>*</sup> Rd,c
40	10.9	13.0	5.0	14.9	16.5	10.7	17.1	18.3	12.4	21.3	23.3	16.7	21.3	28.5	21.0
80	12.0	14.2	6.3	16.3	18.0	12.2	18.8	20.0	13.9	23.4	25.4	18.1	23.4	31.2	22.3
100	12.5	14.8	6.9	17.1	18.7	13.0	19.6	20.8	14.6	24.4	26.5	18.8	24.4	32.5	22.9
150	13.8	16.3	7.6	18.9	20.6	14.9	21.7	22.9	16.4	27.0	29.1	20.5	27.0	35.7	24.6
200	15.1	17.8	7.6	20.6	22.5	16.8	23.7	25.0	18.3	29.5	31.8	22.2	29.5	39.0	26.2

ANCHOR <b>M10</b>	Edge C (mm)														
	45			80			100			150			200		
	tension		shear	tension		shear	tension		shear	tension		shear	tension		shear
spacing s1 (mm)	N <sup>*</sup> Rd,p	N <sup>*</sup> Rd,c	V <sup>*</sup> Rd,c	N <sup>*</sup> Rd,p	N <sup>*</sup> Rd,c	V <sup>*</sup> Rd,c	N <sup>*</sup> Rd,p	N <sup>*</sup> Rd,c	V <sup>*</sup> Rd,c	N <sup>*</sup> Rd,p	N <sup>*</sup> Rd,c	V <sup>*</sup> Rd,c	N <sup>*</sup> Rd,p	N <sup>*</sup> Rd,c	V <sup>*</sup> Rd,c
45	16.4	17.3	6.6	20.7	20.6	11.9	23.3	22.6	15.4	30.6	27.9	20.3	32.9	33.8	25.2
80	17.6	18.5	7.8	22.2	22.0	13.4	25.1	24.1	16.9	32.9	29.8	21.8	35.4	36.1	26.8
100	18.3	19.1	8.6	23.1	22.8	14.2	26.1	25.0	17.8	34.2	30.9	22.6	36.9	37.4	27.4
150	20.1	20.8	9.9	25.4	24.8	16.3	28.7	27.2	20.0	37.6	33.6	24.7	40.5	40.7	29.3
200	22.0	22.5	9.9	27.7	26.8	18.4	31.2	29.4	22.2	40.9	36.3	26.7	44.1	44.0	31.3
250	23.7	24.2	9.9	29.9	28.8	20.1	33.7	31.5	24.5	44.2	39.0	28.8	47.6	47.2	33.3

ANCHOR <b>M12</b>	Edge C (mm)														
	55			80			100			150			200		
	tension		shear	tension		shear	tension		shear	tension		shear	tension		shear
spacing s1 (mm)	N <sup>*</sup> Rd,p	N <sup>*</sup> Rd,c	V <sup>*</sup> Rd,c	N <sup>*</sup> Rd,p	N <sup>*</sup> Rd,c	V <sup>*</sup> Rd,c	N <sup>*</sup> Rd,p	N <sup>*</sup> Rd,c	V <sup>*</sup> Rd,c	N <sup>*</sup> Rd,p	N <sup>*</sup> Rd,c	V <sup>*</sup> Rd,c	N <sup>*</sup> Rd,p	N <sup>*</sup> Rd,c	V <sup>*</sup> Rd,c
55	22.9	26.0	9.1	26.6	29.7	13.3	29.6	32.8	16.9	38.0	41.2	25.4	45.0	48.6	31.2
100	25.1	28.4	11.0	29.1	31.7	15.3	32.5	35.4	19.0	41.6	45.0	27.6	49.2	53.7	33.3
150	27.5	30.3	13.1	31.9	35.1	17.6	35.6	39.2	21.4	45.7	49.2	30.2	54.0	59.4	35.7
200	29.9	33.2	13.7	34.7	38.4	19.8	38.7	42.6	23.8	49.7	53.5	32.7	58.7	65.1	38.1
250	32.3	36.0	13.7	37.5	41.6	21.6	41.8	46.0	26.2	53.7	57.7	35.2	63.4	70.7	40.4
300	34.7	38.9	13.7	40.2	44.7	21.6	44.9	49.4	28.6	57.6	62.0	37.7	68.1	75.8	42.8

ANCHOR <b>M16</b>	Edge C (mm)														
	65			100			150			200			250		
	tension		shear	tension		shear	tension		shear	tension		shear	tension		shear
spacing s1 (mm)	N*Rd,p	N*Rd,c	V*Rd,c	N*Rd,p	N*Rd,c	V*Rd,c	N*Rd,p	N*Rd,c	V*Rd,c	N*Rd,p	N*Rd,c	V*Rd,c	N*Rd,p	N*Rd,c	V*Rd,c
65	35.6	35.4	12.9	41.6	42.0	19.6	50.9	47.4	30.5	61.0	55.1	38.8	72.0	63.4	45.4
100	37.7	37.1	14.7	44.0	42.1	21.5	53.8	49.6	32.6	64.5	57.8	40.9	76.1	66.4	47.4
150	40.6	39.6	17.2	47.4	44.8	24.2	58.0	52.9	35.5	69.6	61.5	43.8	82.1	70.8	50.2
200	43.6	42.0	19.4	50.9	47.6	26.9	62.2	56.1	38.5	74.6	65.3	46.7	88.0	75.1	53.0
250	46.5	44.4	19.4	54.3	50.4	29.6	66.4	59.4	41.4	79.6	69.1	49.6	93.9	79.5	55.7
300	49.4	46.9	19.4	57.7	53.1	32.3	70.6	62.6	44.4	84.6	72.9	52.6	99.9	83.8	58.5

ANCHOR <b>M20</b>	Edge C (mm)														
	90			150			200			250			300		
	tension		shear	tension		shear	tension		shear	tension		shear	tension		shear
spacing s1 (mm)	N*Rd,p	N*Rd,c	V*Rd,c	N*Rd,p	N*Rd,c	V*Rd,c	N*Rd,p	N*Rd,c	V*Rd,c	N*Rd,p	N*Rd,c	V*Rd,c	N*Rd,p	N*Rd,c	V*Rd,c
90	49.7	49.9	20.5	61.5	59.2	34.0	72.2	67.5	46.7	83.6	76.3	54.0	95.8	85.6	61.2
150	53.7	53.2	23.9	66.4	63.1	37.8	77.9	72.0	50.7	90.3	81.4	57.8	103.4	91.3	64.9
200	57.0	56.0	26.8	70.5	66.4	41.0	82.7	75.7	54.1	95.8	85.7	61.1	109.8	96.1	68.0
250	60.4	58.8	29.6	74.6	69.7	44.1	87.6	79.5	57.5	101.4	89.9	64.3	116.2	100.9	71.1
300	63.7	61.5	30.7	78.7	73.0	47.3	92.4	83.3	60.9	107.0	94.2	67.5	122.6	105.6	74.2
350	67.0	64.3	30.7	82.8	76.3	50.4	97.2	87.1	64.3	112.6	98.4	70.7	129.0	110.4	77.3

## Four anchors

**Table 2:** One edge influence – cracked concrete

Design Data:  $f_c=32$  MPa

Anchor size	M8	M10	M12	M16	M20
Min Slab depth	120	150	200	250	300
Embedment Depth	90	110	125	170	205

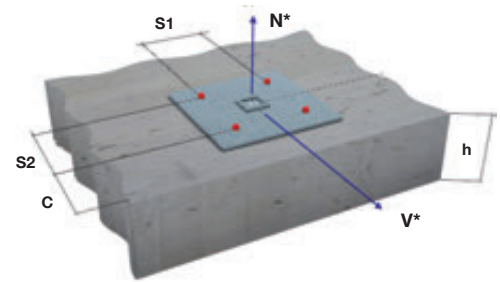
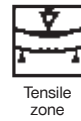

ANCHOR <b>M8</b>	Edge C (mm)														
	40			80			100			150			200		
	tension		shear	tension		shear	tension		shear	tension		shear	tension		shear
spacing $s_1 = s_2$ (mm)	$N^*_{Rd,p}$	$N^*_{Rd,c}$	$V^*_{Rd,c}$	$N^*_{Rd,p}$	$N^*_{Rd,c}$	$V^*_{Rd,c}$	$N^*_{Rd,p}$	$N^*_{Rd,c}$	$V^*_{Rd,c}$	$N^*_{Rd,p}$	$N^*_{Rd,c}$	$V^*_{Rd,c}$	$N^*_{Rd,p}$	$N^*_{Rd,c}$	$V^*_{Rd,c}$
40	15.5	15.2	10.1	20.5	18.8	14.2	23.2	20.7	15.9	28.4	25.9	20.1	28.4	31.4	24.3
80	19.5	19.0	12.6	25.1	23.1	19.0	28.2	25.3	20.6	34.0	31.2	24.8	34.0	37.5	28.9
100	21.7	21.1	13.8	27.6	25.4	21.3	30.9	27.8	22.9	37.0	34.1	27.1	37.0	40.7	31.1
150	27.4	26.6	15.1	34.3	31.7	27.0	38.0	34.4	28.7	44.9	41.7	32.7	44.9	49.3	36.7
200	33.6	32.8	15.1	41.4	38.7	32.7	45.6	41.8	34.3	53.4	50.1	38.3	53.4	58.7	42.2

ANCHOR <b>M10</b>	Edge C (mm)														
	45			80			100			150			200		
	tension		shear	tension		shear	tension		shear	tension		shear	tension		shear
spacing $s_1 = s_2$ (mm)	$N^*_{Rd,p}$	$N^*_{Rd,c}$	$V^*_{Rd,c}$	$N^*_{Rd,p}$	$N^*_{Rd,c}$	$V^*_{Rd,c}$	$N^*_{Rd,p}$	$N^*_{Rd,c}$	$V^*_{Rd,c}$	$N^*_{Rd,p}$	$N^*_{Rd,c}$	$V^*_{Rd,c}$	$N^*_{Rd,p}$	$N^*_{Rd,c}$	$V^*_{Rd,c}$
45	22.2	20.1	13.1	27.3	23.5	17.9	30.4	25.6	19.8	39.0	31.2	24.8	41.8	37.3	29.6
80	26.6	23.7	15.7	32.3	27.6	22.8	35.8	29.9	24.7	45.2	36.0	29.5	48.2	42.7	34.2
100	29.4	25.9	17.2	35.3	30.0	25.5	39.0	32.4	27.4	48.9	38.9	32.1	52.1	46.0	36.8
150	36.7	31.9	19.7	43.5	36.5	32.2	47.7	39.3	34.0	59.0	46.7	38.7	62.6	54.7	43.3
200	44.7	38.5	19.7	52.4	43.7	36.8	57.1	46.8	40.5	69.8	55.1	45.1	73.8	64.1	49.7
250	53.2	45.6	19.7	61.9	51.5	45.1	67.2	55.0	46.9	81.3	64.3	51.4	85.8	74.3	55.8

ANCHOR <b>M12</b>	Edge C (mm)														
	55			80			100			150			200		
	tension		shear	tension		shear	tension		shear	tension		shear	tension		shear
spacing $s_1 = s_2$ (mm)	$N^*_{Rd,p}$	$N^*_{Rd,c}$	$V^*_{Rd,c}$	$N^*_{Rd,p}$	$N^*_{Rd,c}$	$V^*_{Rd,c}$	$N^*_{Rd,p}$	$N^*_{Rd,c}$	$V^*_{Rd,c}$	$N^*_{Rd,p}$	$N^*_{Rd,c}$	$V^*_{Rd,c}$	$N^*_{Rd,p}$	$N^*_{Rd,c}$	$V^*_{Rd,c}$
55	29.8	31.3	18.3	33.9	35.2	23.6	37.4	38.2	26.0	46.9	47.4	31.7	54.6	55.8	37.4
100	37.1	38.7	22.0	41.8	43.4	30.6	45.8	47.2	33.3	56.5	57.3	38.9	65.3	68.1	44.5
150	46.1	48.4	26.2	51.5	53.6	35.1	56.1	57.9	41.2	68.3	69.5	46.7	78.3	82.0	52.1
200	56.0	58.8	27.4	62.2	64.7	39.6	67.4	69.7	47.6	81.2	82.8	54.3	92.4	97.0	59.7
250	66.8	70.2	27.4	73.8	76.9	43.2	79.6	82.5	52.4	95.1	97.2	61.8	107.6	113.2	67.2
300	78.5	82.6	27.4	82.3	90.1	43.2	92.8	96.4	57.1	110.0	112.9	69.2	123.9	130.7	74.5

ANCHOR <b>M16</b>	Edge C (mm)														
	65			100			150			200			250		
	tension		shear	tension		shear	tension		shear	tension		shear	tension		shear
spacing s1= s2 (mm)	N*Rd,p	N*Rd,c	V*Rd,c	N*Rd,p	N*Rd,c	V*Rd,c	N*Rd,p	N*Rd,c	V*Rd,c	N*Rd,p	N*Rd,c	V*Rd,c	N*Rd,p	N*Rd,c	V*Rd,c
65	44.3	41.2	25.9	50.9	46.2	34.0	61.1	53.8	40.8	72.1	61.8	47.4	84.0	70.5	53.9
100	50.9	46.5	29.4	58.1	51.8	40.9	69.1	59.9	47.4	81.0	68.6	53.8	93.9	77.8	60.2
150	61.1	54.5	34.3	69.1	60.4	48.4	81.4	69.4	56.5	94.7	78.9	62.8	109.0	89.0	69.1
200	72.2	63.1	38.8	81.1	69.6	53.8	94.8	79.4	65.5	109.5	89.9	71.7	125.3	100.9	77.9
250	84.1	72.4	38.8	94.0	79.5	59.2	109.1	90.2	74.2	125.3	101.6	80.4	142.7	113.6	86.5
300	97.0	82.3	38.8	107.9	90.0	64.6	124.4	101.6	82.9	142.2	114.0	89.0	161.2	127.0	95.0

ANCHOR <b>M20</b>	Edge C (mm)														
	90			150			200			250			300		
	tension		shear	tension		shear	tension		shear	tension		shear	tension		shear
spacing s1= s2 (mm)	N*Rd,p	N*Rd,c	V*Rd,c	N*Rd,p	N*Rd,c	V*Rd,c	N*Rd,p	N*Rd,c	V*Rd,c	N*Rd,p	N*Rd,c	V*Rd,c	N*Rd,p	N*Rd,c	V*Rd,c
90	63.3	59.0	41.0	76.4	68.8	52.5	88.1	77.6	59.8	100.7	86.8	67.0	114.1	96.5	74.1
150	76.3	69.4	47.8	90.9	80.3	64.9	104.1	89.9	72.0	118.1	100.1	79.0	133.0	110.8	86.0
200	88.0	78.7	53.5	104.0	90.5	75.0	118.4	100.9	81.9	133.7	111.9	88.8	149.8	123.4	95.7
250	100.5	88.5	59.2	118.0	101.3	84.9	133.6	112.5	91.7	150.2	124.3	98.5	167.7	136.7	105.4
300	113.8	99.0	61.5	132.8	112.7	94.5	149.7	124.7	101.4	167.6	137.4	108.1	186.6	150.7	114.8
350	127.9	110.0	61.5	148.4	124.7	100.9	166.7	137.6	110.9	186.0	151.2	117.6	206.4	165.4	124.3

## Setting instructions

### Bore hole drilling

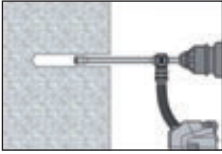

Drill hole to the required embedment depth with an appropriately sized Hilti TE-CD or TE-YD hollow drill bit with Hilti vacuum attachment. This drilling method properly cleans the borehole and removes dust while drilling. After drilling is complete, proceed to the “injection preparation” step in the instructions for use

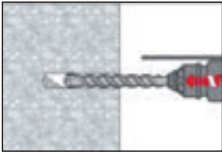

Drill Hole to the required embedment depth with a hammer drill set in rotation-hammer mode using an appropriately sized carbide drill bit.

### Bore hole cleaning Just before setting an anchor, the bore hole must be free of dust and debris.

a) Manual Cleaning (MC) non-cracked concrete only for bore hole diameters  $d_0 \leq 20\text{mm}$  and bore hole depth  $h_0 \leq 10d$  for HIS- R(N) M8 and M10.

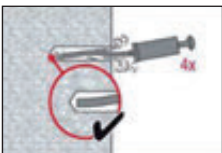

The Hilti manual pump may be used for blowing out bore holes up to diameters  $d_0 \leq 20\text{ mm}$  and embedment depths up to  $h_{ef} \leq 10d$ . Blow out at least 4 times from the back of the bore hole until return air stream is free of noticeable dust

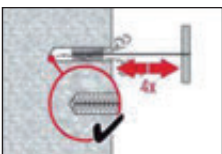

Brush 4 times with the specified brush size by inserting the steel brush Hilti HIT-RB to the back of the hole (if needed with extension) in a twisting motion and removing it. The brush must produce natural resistance as it enters the bore hole – if not the brush is too small and must be replaced with the proper brush diameter.

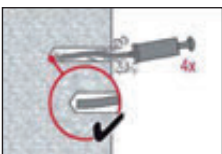

Blow out again with manual pump at least 4 times until return air stream is free of noticeable dust.

b) Compressed air cleaning (CAC) for all bore hole diameters  $d_0$  and all bore hole depth  $h_0$  for HIS-R(N) M12, M16 and M20.



Blow 2 times from the back of the hole (if needed with nozzle extension) over the hole length with oil-free compressed air (min. 6 bar at 6 m<sup>3</sup>/h) until return air stream is free of noticeable dust. Bore hole diameter  $\geq 32\text{ mm}$  the compressor must supply a minimum air flow of 140 m<sup>3</sup>/hour.

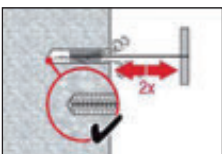

Brush 2 times with the specified brush size (brush  $\varnothing \geq$  bore hole  $\varnothing$ , see Table 6) by inserting the steel brush Hilti HIT-RB to the back of the hole (if needed with extension) in a twisting motion and removing it. The brush must produce natural resistance as it enters the bore hole -- if not the brush is too small and must be replaced with the proper brush diameter.



Blow again with compressed air 2 times until return air stream is free of noticeable dust.

## Setting instructions

### Injection preparation

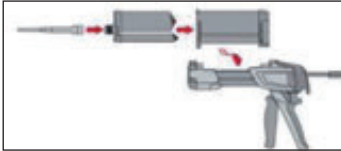

Tightly attach new Hilti mixing nozzle HIT-RE-M to foil pack manifold (snug fit). Do not modify the mixing nozzle. Observe the instruction for use of the dispenser. Check foil pack holder for proper function. Do not use damaged foil packs / holders. Swing foil pack holder with foil pack into HIT dispenser.

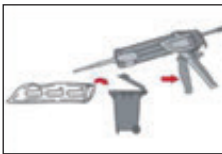

Discard initial adhesive. The foil pack opens automatically as dispensing is initiated. Depending on the size of the foil pack an initial amount of adhesive has to be discarded.

Discard quantities are:

2 strokes for 330 ml foil pack,

3 strokes for 500 ml foil pack,

4 strokes for 500 ml foil pack  $\leq 5^{\circ}\text{C}$ .

### Inject adhesive from the back of the borehole without forming air voids

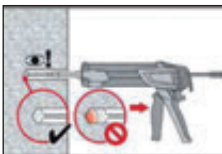

Inject the adhesive starting at the back of the hole, slowly withdrawing the mixer with each trigger pull. Fill holes approximately 2/3 full, or as required to ensure that the annular gap between the anchor and the concrete is completely filled with adhesive along the embedment length.

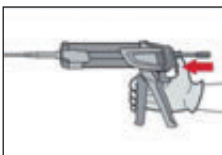

After injection is completed, depressurise the dispenser by pressing the release trigger. This will prevent further adhesive discharge from the mixer.

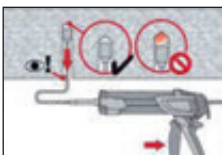

Overhead installation and/or installation with embedment depth  $h_{ef} > 250\text{mm}$ . For overhead installation the injection is only possible with the aid of extensions and piston plugs. Assemble HIT-RE-M mixer, extension(s) and appropriately sized piston plug. Insert piston plug to back of the hole and inject adhesive. During injection the piston plug will be naturally extruded out of the bore hole by the adhesive pressure.

### Setting the element

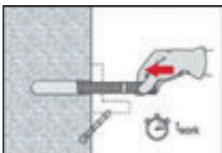

Before use, verify that the element is dry and free of oil and other contaminants.

Mark and set element to the required embedment depth until working time  $t_{work}$  has elapsed

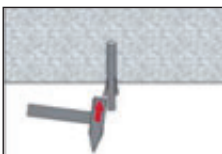

For overhead installation use piston plugs and fix embedded parts with e.g. wedges

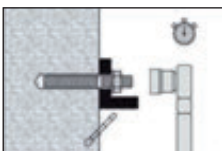

Loading the anchor:

After required curing time  $t_{cure}$  the anchor can be loaded.

The applied installation torque shall not exceed  $T_{max}$ .

For detailed information on installation see instruction for use given with the package of the product.

## Materials

### Mechanical properties of HIS-(R)N

Anchor size			M8x90	M10x110	M12x125	M16x170	M20x205
Nominal tensile strength $f_{uk}$	HIS-N	[N/mm <sup>2</sup> ]	490	490	460	460	460
	Screw 8.8	[N/mm <sup>2</sup> ]	800	800	800	800	800
	HIS-RN	[N/mm <sup>2</sup> ]	700	700	700	700	700
	Screw A4-70	[N/mm <sup>2</sup> ]	700	700	700	700	700
Yield strength $f_{yk}$	HIS-N	[N/mm <sup>2</sup> ]	410	375	375	375	375
	Screw 8.8	[N/mm <sup>2</sup> ]	640	640	640	640	640
	HIS-RN	[N/mm <sup>2</sup> ]	350	350	350	350	350
	Screw A4-70	[N/mm <sup>2</sup> ]	450	450	450	450	450
Stressed cross-section $A_s$	HIS-(R)N	[mm <sup>2</sup> ]	51.5	108.0	169.1	256.1	237.6
	Screw	[mm <sup>2</sup> ]	36.6	58	84.3	157	245
Moment of resistance $W$	HIS-(R)N	[mm <sup>3</sup> ]	145	430	840	1595	1543
	Screw	[mm <sup>3</sup> ]	31.2	62.3	109	277	541

## Material quality

Part	Material
Internal threaded sleeve <sup>a)</sup> HIS-N	C-steel 1.0718 Steel galvanized $\geq 5\mu\text{m}$
Internal threaded sleeve <sup>b)</sup> HIS-RN	Stainless steel 1.4401 and 1.4571

a) related fastening screw: strength class 8.8,  $A_s > 8\%$  Ductile  
steel galvanized  $\geq 5\mu\text{m}$

b) related fastening screw: strength class 70,  $A_s > 8\%$  Ductile  
stainless steel 1.4401; 1.4404; 1.4578; 1.4571; 1.4439; 1.4362

## Anchor dimensions

Anchor size	M8	M10	M12	M16	M20
Internal threaded sleeve HIS-(R)N	M8x90	M10x110	M12x125	M16x170	M20x205
Anchor embedment depth [mm]	90	110	125	170	205

## Setting

### Installation equipment

Anchor size	M8x90	M10x110	M12x125	M16x170	M20x205
Rotary hammer	TE 2 – TE 30		TE 40 – TE 70		
Other tools	compressed air gun or blow out pump, set of cleaning brushes, dispenser				

## Working time, curing time

Temperature of the base material $T_{BM}$	Working time in which anchor can be inserted and adjusted $t_{work}$	Curing time before anchor can be loaded $t_{cure}$
-10 °C to -5 °C	3 hour	20 hour
-4 °C to 0 °C	2 hour	7 hour
1 °C to 5 °C	1 hour	3 hour
6 °C to 10 °C	40 min	2 hour
11 °C to 20 °C	15 min	1 hour
21 °C to 30 °C	9 min	1 hour
31 °C to 40 °C	6 min	1 hour

## Setting details

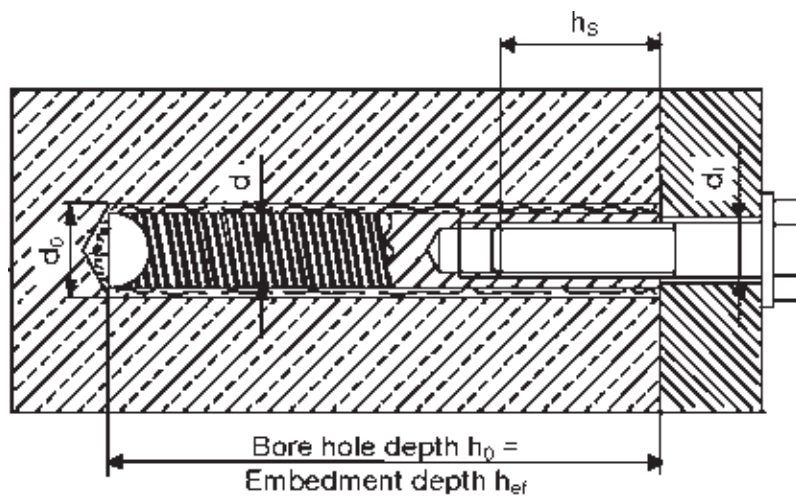



Anchor size		M8x90	M10x110	M12x125	M16x170	M20x205
Nominal diameter of drill bit	$d_0$ [mm]	14	18	22	28	32
Diameter of element	$d$ [mm]	12,5	16,5	20,5	25,4	27,6
Effective anchorage and drill hole depth	$h_{ef}$ [mm]	90	110	125	170	205
Minimum base material thickness	$h_{min}$ [mm]	120	150	170	230	270
Diameter of clearance hole in the fixture	$d_f$ [mm]	9	12	14	18	22
Thread engagement length; min - max	$h_s$ [mm]	8-20	10-25	12-30	16-40	20-50
Torque moment <sup>a)</sup>	$T_{max}$ [Nm]	10	20	40	80	150
Minimum spacing	$s_{min}$ [mm]	40	45	55	65	90
Minimum edge distance	$c_{min}$ [mm]	40	45	55	65	90

a) Maximum recommended torque moment to avoid splitting failure during installation with minimum spacing and/or edge distance.



## Hilti HIT-HY 200 with HIT-Z

Injection Mortar System	Benefits
 <p>Hilti HIT-HY 200-R 500 ml foil pack (also available as 330 ml foil pack)</p>	<ul style="list-style-type: none"> <li>■ No cleaning required: Zero susceptibility to borehole cleaning conditions with dry and water saturated concrete base material</li> <li>■ Maximum load performance in cracked concrete and uncracked concrete</li> <li>■ Suitable for cracked and non-cracked concrete C 20/25 to C 50/60</li> <li>■ Suitable for use with diamond cored holes in non-cracked or cracked concrete with no load reductions</li> </ul>
 <p>Static mixer</p>	
 <p>HIT-Z HIT-Z-R rod</p>	



Concrete



Tensile zone



Corrosion resistance



European Technical Approval



CE conformity



PROFIS anchor design software



No cleaning required for approved loads



Seismic



Diamond drilled holes

### Approvals / certificates

Description	Authority / Laboratory	No. / date of issue
European technical approval <sup>a)</sup>	DIBt, Berlin	ETA-12/0028 / 2013-03-15 (HIT-HY 200-R)
Fire test report	IBMB, Brunswick	3501/676/13 / 2012-08-03

a) All data given in this section according ETA-12/0028, issue 2013-03-15.

### Service temperature range

Hilti HIT-HY 200 injection mortar may be applied in the temperature ranges given below. An elevated base material temperature may lead to a reduction of the design bond resistance.

Temperature range	Base material temperature	Maximum long term base material temperature	Maximum short term base material temperature
Temperature range I	-40 °C to +40 °C	+24 °C	+40 °C
Temperature range II	-40 °C to +80 °C	+40 °C	+80 °C
Temperature range III	-40 °C to +120 °C	+72 °C	+120 °C

#### Max short term base material temperature

Short-term elevated base material temperatures are those that occur over brief intervals, e.g. as a result of diurnal cycling.

#### Max long term base material temperature

Long-term elevated base material temperatures are roughly constant over significant periods of time

## Design process for typical anchor layouts

The design values in the tables are obtained from Profis V2.4.3 in compliance with the design method according to EOTA TR 029. Design resistance according to data given in ETA-12/2008 issue 2013-03-15.

- Influence of concrete strength
- Influence of edge distance
- Influence of spacing

The design method is based on the following simplification:

- No different loads are acting on individual anchors (no eccentricity)

The values are valid for the anchor configuration.

For more complex fastening applications please use the anchor design software PROFIS Anchor.

### STEP 1: TENSION LOADING

The design tensile resistance  $N_{Rd}$  is the lower of:

- Combined pull-out and concrete cone resistance

$$N_{Rd,p} = f_{B,p} \cdot N^*_{Rd,p}$$

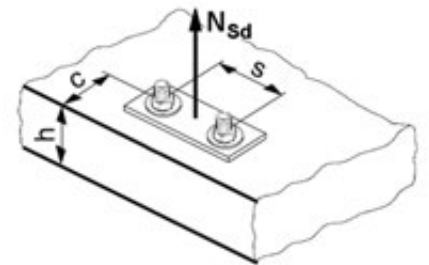

$N^*_{Rd,p}$  is obtained from the relevant design tables

$f_{B,p}$  influence of concrete strength on combined pull-out and concrete cone resistance

Concrete Strengths $f'_{c,cyl}$ (MPa)	20	25	32	40	50
$f_{B,p}$	1.00	1.00	1.00	1.00	1.00

- Concrete cone or concrete splitting resistance

$$N_{Rd,c} = f_B \cdot N^*_{Rd,c}$$

$N^*_{Rd,c}$  is obtained from the relevant design tables

$f_B$  influence of concrete strength on concrete cone resistance

Concrete Strengths $f'_{c,cyl}$ (MPa)	20	25	32	40	50
$f_B$	0.79	0.87	1.00	1.11	1.22

The definition of dry concrete, as per Hilti is: concrete not in contact with water before/during installation and curing.

- Design steel resistance (tension)  $N_{Rd,s}$

Anchor size		M8	M10	M12	M16	M20	
$N_{Rd,s}$	HIT-Z / HIT-Z-R	[kN]	16.0	25.3	36.7	64.0	97.3

$$N_{Rd} = \min \{ N_{Rd,p}, N_{Rd,c}, N_{Rd,s} \}$$

**CHECK  $N_{Rd} \geq N_{Sd}$**

**STEP 2: SHEAR LOADING**

The design shear resistance  $V_{Rd}$  is the lower of:

■ **Design Concrete Edge Resistance**

$$V_{Rd,c} = f_B \cdot V^*_{Rd,c} \cdot \psi_{re,V}$$

$V^*_{Rd,c}$  is obtained from the relevant design table

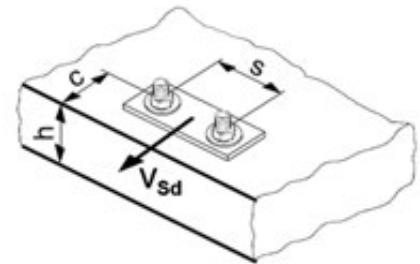

The factor  $\psi_{re,V}$  takes account of the effect of the type of reinforcement used in cracked concrete.

$\psi_{re,V} = 1.0$  anchorage in non-cracked concrete

$\psi_{re,V} = 1.0$  anchorage in cracked concrete without edge reinforcement

$\psi_{re,V} = 1.2$  anchorage in cracked concrete with straight edge reinforcement ( $\geq \phi 12$  mm)

$\psi_{re,V} = 1.4$  anchorage in cracked concrete with edge reinforcement and closely spaced stirrups ( $a \leq 100$  mm)

**$f_B$  influence of concrete strength**

Concrete Strengths $f'_{c,cyl}$ (MPa)	20	25	32	40	50
$f_B$	0.79	0.87	1.00	1.11	1.22

**Shear load acting parallel to edge:**

These tables are for a single free edge only

**2 anchors:**

For shear loads acting parallel to this edge, the concrete resistance  $V^*_{Rd,c}$  can be multiplied by the factor = 2.5

**4 anchors:**

For shear loads acting parallel to the edge - the anchor row closest to the edge is checked to resist half the total design load. To obtain the concrete resistance use the corresponding 2 anchor configuration  $V^*_{Rd,c}$  and multiply by the factor = 2.5

■ **Design steel resistance (shear):  $V_{Rd,s}$**

Anchor size		M8	M10	M12	M16	M20	
$V_{Rd,s}$	HIT-Z	[kN]	9.6	15.2	21.6	38.4	58.4
	HIT-Z-R	[kN]	11.2	18.4	26.4	45.6	70.4

$$V_{Rd} = \min \{ V_{Rd,c}, V_{Rd,s} \}$$

**CHECK  $V_{Rd} \geq V_{Sd}$**

**STEP 3: COMBINED TENSION AND SHEAR LOADING**

The following equations must be satisfied:

$$N_{Sd}/N_{Rd} + V_{Sd}/V_{Rd} \leq 1.2$$

and

$$N_{Sd}/N_{Rd} \leq 1, V_{Sd}/V_{Rd} \leq 1$$

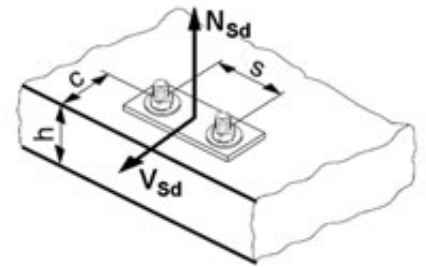

## Precalculated table values – design resistance values

### All data applies to:

■ temperature range I (see service temperature range)

■ no effects of dense reinforcement

Recommended loads can be calculated by dividing the design resistance by an overall partial safety factor for action  $\gamma = 1,4$ . The partial safety factors for action depend on the type of loading and shall be taken from national regulations.

## Basic loading data (for a single anchor) – no edge distance and spacing influence

### Embedment depth and base material thickness for the basic loading data



Anchor size	M8	M10	M12	M16	M20
Typical embedment depth $h_{ef}$ [mm]	70	90	110	145	180
Base material thickness $h$ [mm]	130	150	170	245	280

### Design resistance: concrete 32 MPa



Anchor size		M8	M10	M12	M16	M20
Non-cracked concrete						
Tensile	Concrete Pull $N_{Rd,p}^*$	Steel governed refer $N_{Rd,s}$ table		36.2	nc	nc
	Concrete Cone $N_{Rd,c}^*$			nc	74.4	102.8
Shear	$V_{Rd,s}$	Steel governed refer $V_{Rd,s}$ table				
Cracked concrete						
Tensile	Concrete Pull $N_{Rd,p}^*$	nc	nc	33.1	nc	nc
	Concrete Cone $N_{Rd,c}^*$	17.8	25.9	35.0	53.0	73.3
Shear	$V_{Rd,s}$	NA	Steel governed refer $V_{Rd,s}$ table			

## Basic loading data (for a single anchor) – with minimum edge distance

### Design resistance [kN] - uncracked concrete, 32 Mpa

Anchor size		M8	M10	M12	M16	M20	
Min. edge distance	$c_{min}$ [mm]	40	65	80	90	120	
Min Base thickness	$h_{min}$ [mm]	130	150	170	245	280	
<b>Tensile NRd</b>							
	Pull-out	$N_{Rd,p}^*$ [kN]	13.3	NOT CRITICAL			
	Concrete	$N_{Rd,c}^*$ [kN]	11.8	17.6	23.3	34.7	47.8
<b>Shear VRd</b>							
	Shear (without lever arm)	$V_{Rd,c}$	4.5	9.4	13.4	17.4	27.5

### Design resistance [kN] - cracked concrete, 32 Mpa

Anchor size		M8	M10	M12	M16	M20	
Min. edge distance	$c_{min}$ [mm]	40	65	80	90	120	
Min Base thickness	$h_{min}$ [mm]	130	150	170	245	280	
<b>Tensile NRd</b>							
	Pull-out	$N_{Rd,p}^*$ [kN]	NOT CRITICAL				
	Concrete	$N_{Rd,c}^*$ [kN]	8.4	12.6	16.6	24.8	34.1
<b>Shear VRd</b>							
	Shear (without lever arm)	$V_{Rd,c}$	3.2	6.7	9.4	12.3	19.5

## Two anchors

**Table 1:** One edge influence – non cracked concrete

Design Data:  $f_{c,cyl}=32$  MPa

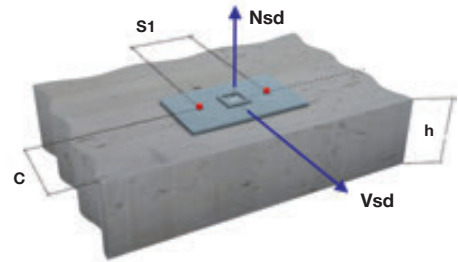

Anchor size	M8	M10	M12	M16	M20
Typical embedment depth $h_{ef}$ [mm]	70	90	110	145	180
Min Slab depth	130	150	170	245	280

ANCHOR <b>M8</b>	Edge C (mm)														
	40			80			100			150			170		
	tension		shear	tension		shear	tension		shear	tension		shear	tension		shear
spacing $s_1$ (mm)	$N^*_{Rd,p}$	$N^*_{Rd,c}$	$V^*_{Rd,c}$	$N^*_{Rd,p}$	$N^*_{Rd,c}$	$V^*_{Rd,c}$	$N^*_{Rd,p}$	$N^*_{Rd,c}$	$V^*_{Rd,c}$	$N^*_{Rd,p}$	$N^*_{Rd,c}$	$V^*_{Rd,c}$	$N^*_{Rd,p}$	$N^*_{Rd,c}$	$V^*_{Rd,c}$
40	-	-	-	NOT CRITICAL	17.0	13.4	NOT CRITICAL	19.1	16.4	25.5	24.8	22.5	25.5	27.3	24.9
80	NOT CRITICAL	14.5	7.6		18.8	15.3		21.1	18.4	30.8	27.4	24.3	30.8	30.1	26.7
100		15.2	8.4		19.6	16.3		22.1	19.3	33.5	28.7	25.2	33.5	31.5	27.6
120		15.9	9.2		20.5	17.3		23.0	20.3	36.2	29.9	26.1	36.2	32.9	28.5
150		16.9	9.2		21.8	18.7		24.5	21.7	40.2	31.9	27.5	40.2	35.0	29.8
200		18.6	9.2		24.0	21.1		27.0	24.1	40.2	35.1	29.8	40.2	38.6	32.1

ANCHOR <b>M10</b>	Edge C (mm)														
	80			110			150			200			250		
	tension		shear	tension		shear	tension		shear	tension		shear	tension		shear
spacing $s_1$ (mm)	$N^*_{Rd,p}$	$N^*_{Rd,c}$	$V^*_{Rd,c}$	$N^*_{Rd,p}$	$N^*_{Rd,c}$	$V^*_{Rd,c}$	$N^*_{Rd,p}$	$N^*_{Rd,c}$	$V^*_{Rd,c}$	$N^*_{Rd,p}$	$N^*_{Rd,c}$	$V^*_{Rd,c}$	$N^*_{Rd,p}$	$N^*_{Rd,c}$	$V^*_{Rd,c}$
80	-	-	-	NOT CRITICAL	24.8	22.5	NOT CRITICAL	29.0	27.8	NOT CRITICAL	34.8	34.3	43.6	41.0	40.7
100	-	-	-		25.6	23.6		30.0	28.8		35.9	35.3	46.9	42.3	41.7
150	NOT CRITICAL	24.4	20.2		27.7	26.4		32.5	31.4		38.9	37.8	55.3	45.8	44.2
200		26.2	22.8		29.8	29.1		34.9	34.1		41.8	40.3	60.3	49.2	46.6
250		28.0	24.9		31.9	31.8		37.3	36.7		44.7	42.8	60.3	52.7	49.1
300		29.9	24.9		34.0	34.6		39.8	39.3		47.6	45.4	60.3	56.1	51.5

ANCHOR <b>M12</b>	Edge C (mm)														
	100			150			200			250			300		
	tension		shear	tension		shear	tension		shear	tension		shear	tension		shear
spacing $s_1$ (mm)	$N^*_{Rd,p}$	$N^*_{Rd,c}$	$V^*_{Rd,c}$	$N^*_{Rd,p}$	$N^*_{Rd,c}$	$V^*_{Rd,c}$	$N^*_{Rd,p}$	$N^*_{Rd,c}$	$V^*_{Rd,c}$	$N^*_{Rd,p}$	$N^*_{Rd,c}$	$V^*_{Rd,c}$	$N^*_{Rd,p}$	$N^*_{Rd,c}$	$V^*_{Rd,c}$
150	-	-	-	NOT CRITICAL	35.8	35.4	NOT CRITICAL	41.6	42.3	NOT CRITICAL	47.7	49.2	66.4	54.2	56.1
180	NOT CRITICAL	31.6	28.6		37.1	37.2		43.1	44.0		49.4	50.9	72.4	56.1	57.7
200		32.3	29.8		38.0	38.4		44.1	45.2		50.5	52.0	72.4	57.4	58.8
250		34.2	32.8		40.1	41.3		46.5	48.0		53.4	54.7	72.4	60.7	61.5
300		36.0	35.7		42.3	44.3		49.0	50.8		56.2	57.4	72.4	63.9	64.1
350		37.8	35.7		44.4	47.2		51.5	53.6		59.1	60.2	72.4	67.1	66.8

ANCHOR <b>M16</b>	Edge C (mm)														
	120			150			200			250			300		
	tension		shear	tension		shear	tension		shear	tension		shear	tension		shear
spacing s1 (mm)	N*Rd,p	N*Rd,c	V*Rrd,c	N*Rd,p	N*Rd,c	V*Rrd,c	N*Rd,p	N*Rd,c	V*Rrd,c	N*Rd,p	N*Rd,c	V*Rrd,c	N*Rd,p	N*Rd,c	V*Rrd,c
150	-	-	-	NOT CRITICAL	48.7	44.8	NOT CRITICAL	55.5	55.3	NOT CRITICAL	62.6	63.9	NOT CRITICAL	70.2	72.4
180	NOT CRITICAL	46.2	37.7		50.2	47.0		57.2	57.5		64.6	66.0		72.3	74.5
210		47.6	39.8		51.7	49.2		58.9	59.7		66.5	68.1		74.5	76.5
250		49.5	42.6		53.7	52.2		61.2	62.7		69.1	71.0		77.4	79.3
300		51.8	46.1		56.3	55.9		64.1	66.3		72.3	74.5		81.0	82.7
350		54.1	49.6		58.8	59.7		66.9	70.0		75.6	78.1		84.7	86.2

ANCHOR <b>M20</b>	Edge C (mm)														
	180			200			250			300			350		
	tension		shear	tension		shear	tension		shear	tension		shear	tension		shear
spacing s1 (mm)	N*Rd,p	N*Rd,c	V*Rrd,c	N*Rd,p	N*Rd,c	V*Rrd,c	N*Rd,p	N*Rd,c	V*Rrd,c	N*Rd,p	N*Rd,c	V*Rrd,c	N*Rd,p	N*Rd,c	V*Rrd,c
150	-	-	-	NOT CRITICAL	64.1	63.7	NOT CRITICAL	70.6	73.2	NOT CRITICAL	77.4	82.6	NOT CRITICAL	84.5	91.9
180	NOT CRITICAL	63.0	61.4		65.6	66.3		72.3	75.6		79.3	84.9		86.5	94.2
210		64.5	64.0		67.2	68.8		74.0	78.0		81.1	87.3		88.5	96.5
250		66.5	67.4		69.2	72.2		76.2	81.3		83.6	90.4		91.2	99.6
300		68.9	71.7		71.7	76.5		79.0	85.4		86.6	94.4		94.6	103.4
350		71.3	75.9		74.3	80.7		81.8	89.4		89.7	98.3		97.9	107.2



## Four anchors

**Table 2:** One edge influence – non cracked concrete

Design Data:  $f_{c,cyl}=32$  MPa

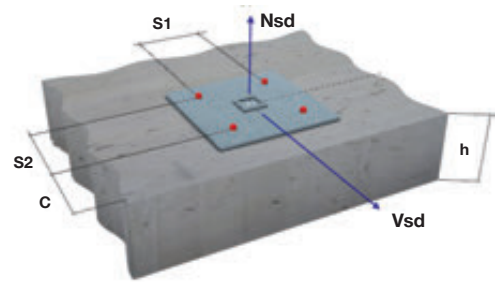

Anchor size	M8	M10	M12	M16	M20
Typical embedment depth $h_{ef}$ [mm]	70	90	110	145	180
Min Slab depth	130	150	170	245	280

ANCHOR <b>M8</b>	Edge C (mm)														
	40			80			100			150			170		
	tension		shear	tension		shear	tension		shear	tension		shear	tension		shear
spacing $s_1 = s_2$	$N^*_{Rd,p}$	$N^*_{Rd,c}$	$V^*_{Rd,c}$	$N^*_{Rd,p}$	$N^*_{Rd,c}$	$V^*_{Rd,c}$	$N^*_{Rd,p}$	$N^*_{Rd,c}$	$V^*_{Rd,c}$	$N^*_{Rd,p}$	$N^*_{Rd,c}$	$V^*_{Rd,c}$	$N^*_{Rd,p}$	$N^*_{Rd,c}$	$V^*_{Rd,c}$
40	-	-	-	NOT CRITICAL	19.7	13.4	NOT CRITICAL	21.9	16.4	32.3	27.9	22.5	32.3	31.0	28.4
80	NOT CRITICAL	19.9	7.6		24.7	15.3		27.2	18.4	47.3	34.1	24.3	47.3	37.7	30.2
100		22.3	8.4		27.4	16.3		30.1	19.3	55.9	37.5	25.2	55.9	41.3	31.1
120		24.8	9.2		30.2	17.3		33.1	20.3	65.1	41.0	26.1	65.1	45.1	32.0
150		28.7	9.2		34.7	18.7		37.9	21.7	80.4	46.6	27.5	80.4	51.1	33.3
200		35.9	9.2		42.9	21.1		46.7	24.1	80.4	56.7	29.8	80.4	61.9	35.5

ANCHOR <b>M10</b>	Edge C (mm)														
	80			110			150			200			250		
	tension		shear	tension		shear	tension		shear	tension		shear	tension		shear
spacing $s_1 = s_2$	$N^*_{Rd,p}$	$N^*_{Rd,c}$	$V^*_{Rd,c}$	$N^*_{Rd,p}$	$N^*_{Rd,c}$	$V^*_{Rd,c}$	$N^*_{Rd,p}$	$N^*_{Rd,c}$	$V^*_{Rd,c}$	$N^*_{Rd,p}$	$N^*_{Rd,c}$	$V^*_{Rd,c}$	$N^*_{Rd,p}$	$N^*_{Rd,c}$	$V^*_{Rd,c}$
100	NOT CRITICAL	31.5	22.3	NOT CRITICAL	37.4	28.8	NOT CRITICAL	43.8	35.3	NOT CRITICAL	50.7	41.7	NOT CRITICAL	51.8	48.1
130		35.1	24.0		41.5	30.4		48.4	36.8		55.8	43.2		57.0	49.5
170		40.4	26.2		47.4	32.5		54.9	38.8		62.9	45.1		64.3	51.4
200		44.5	27.9		52.0	34.1		60.0	40.3		68.6	46.6		70.0	52.9
250		51.9	30.7		60.2	36.7		69.1	42.8		78.6	49.1		80.1	55.3
300		59.9	33.5		69.0	39.3		78.8	45.4		89.2	51.5		90.9	57.7

ANCHOR <b>M12</b>	Edge C (mm)														
	100			150			200			250			300		
	tension		shear	tension		shear	tension		shear	tension		shear	tension		shear
spacing $s_1 = s_2$	$N^*_{Rd,p}$	$N^*_{Rd,c}$	$V^*_{Rd,c}$	$N^*_{Rd,p}$	$N^*_{Rd,c}$	$V^*_{Rd,c}$	$N^*_{Rd,p}$	$N^*_{Rd,c}$	$V^*_{Rd,c}$	$N^*_{Rd,p}$	$N^*_{Rd,c}$	$V^*_{Rd,c}$	$N^*_{Rd,p}$	$N^*_{Rd,c}$	$V^*_{Rd,c}$
100	-	-	-	NOT CRITICAL	40.5	32.5	NOT CRITICAL	46.3	39.5	NOT CRITICAL	52.4	46.5	NOT CRITICAL	58.8	53.4
150	-	-	-		46.8	35.4		53.1	42.3		59.7	49.2		66.8	56.1
200	NOT CRITICAL	47.0	29.8		53.4	38.4		60.3	45.2		67.6	52.0		75.3	58.8
250		53.5	32.8		60.5	41.3		68.0	48.0		75.9	54.7		84.3	61.5
300		60.4	35.7		68.1	44.3		76.2	50.8		84.7	57.4		93.8	64.1
350		67.7	35.7		76.0	47.2		84.8	53.6		94.0	60.2		103.7	66.8

ANCHOR <b>M16</b>	Edge C (mm)														
	120			150			200			250			300		
	tension		shear	tension		shear	tension		shear	tension		shear	tension		shear
spacing s1 = s2	N*Rd,p	N*Rd,c	V*Rrd,c	N*Rd,p	N*Rd,c	V*Rrd,c	N*Rd,p	N*Rd,c	V*Rrd,c	N*Rd,p	N*Rd,c	V*Rrd,c	N*Rd,p	N*Rd,c	V*Rrd,c
120	-	-	-	NOT CRITICAL	57.3	42.5	NOT CRITICAL	64.3	53.1	NOT CRITICAL	71.7	61.7	NOT CRITICAL	79.5	70.3
170	NOT CRITICAL	60.5	37.0		64.8	46.2		72.4	56.8		80.4	65.3		88.8	73.8
200		65.0	39.1		69.6	48.5		77.5	59.0		85.8	67.4		94.6	75.9
250		72.9	42.6		77.8	52.2		86.3	62.7		95.3	71.0		104.7	79.3
300		81.2	46.1		86.4	55.9		95.6	66.3		105.3	74.5		115.3	82.7
350		89.9	49.6		95.6	59.7		105.4	70.0		115.7	78.1		126.5	86.2

ANCHOR <b>M20</b>	Edge C (mm)														
	180			200			250			300			350		
	tension		shear	tension		shear	tension		shear	tension		shear	tension		shear
spacing s1 = s2	N*Rd,p	N*Rd,c	V*Rrd,c	N*Rd,p	N*Rd,c	V*Rrd,c	N*Rd,p	N*Rd,c	V*Rrd,c	N*Rd,p	N*Rd,c	V*Rrd,c	N*Rd,p	N*Rd,c	V*Rrd,c
150	-	-	-	NOT CRITICAL	76.8	63.7	NOT CRITICAL	83.8	73.2	NOT CRITICAL	91.0	82.6	NOT CRITICAL	98.5	91.9
200	-	-	-		84.3	68.0		91.7	77.2		99.3	86.5		107.3	95.7
250	-	-	-		92.1	72.2		99.9	81.3		108.0	90.4		116.4	99.6
300	NOT CRITICAL	92.3	60.9		100.2	76.5		108.4	85.4		117.0	94.4		125.9	103.4
350		100.3	64.9		108.7	80.7		117.4	89.4		126.4	98.3		135.8	107.2
400		108.6	69.0		117.4	85.0		126.6	93.5		136.1	102.2		146.0	111.0

## Two anchors

**Table 1:** One edge influence – cracked concrete

Design Data:  $f_{c,cyl}=32$  MPa – Cracked Concrete

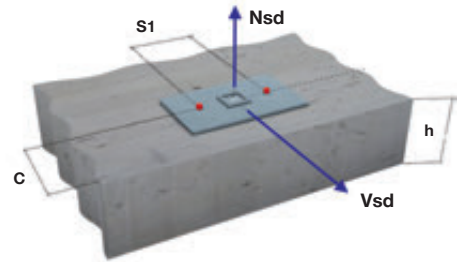
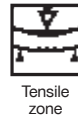

Anchor size	M8	M10	M12	M16	M20
Typical embedment depth $h_{ef}$ [mm]	70	90	110	145	180
Min Slab depth	130	150	170	245	280

ANCHOR <b>M8</b>	Edge C (mm)														
	50			80			100			150			200		
	tension		shear	tension		shear	tension		shear	tension		shear	tension		shear
spacing $s_1$ (mm)	$N^*_{Rd,p}$	$N^*_{Rd,c}$	$V^*_{Rd,c}$	$N^*_{Rd,p}$	$N^*_{Rd,c}$	$V^*_{Rd,c}$	$N^*_{Rd,p}$	$N^*_{Rd,c}$	$V^*_{Rd,c}$	$N^*_{Rd,p}$	$N^*_{Rd,c}$	$V^*_{Rd,c}$	$N^*_{Rd,p}$	$N^*_{Rd,c}$	$V^*_{Rd,c}$
50	NOT CRITICAL	10.3	5.8	NOT CRITICAL	12.4	9.8	NOT CRITICAL	14.0	12.0	NOT CRITICAL	18.2	16.2	24.6	20.3	20.4
100		11.6	7.3		14.0	11.5		15.7	13.7		20.4	17.9	30.7	22.9	22.0
150		12.9	8.7		15.6	13.2		17.5	15.4		22.7	19.5	36.9	25.4	23.6
200		14.2	8.7		17.1	14.9		19.2	17.1		25.0	21.1	36.9	28.0	25.2
250		15.5	8.7		18.7	16.3		21.0	18.8		27.3	22.7	36.9	30.6	26.7
300		16.8	8.7		20.3	16.3		22.7	20.5		29.6	24.4	36.9	33.1	28.3

ANCHOR <b>M10</b>	Edge C (mm)														
	70			90			110			150			200		
	tension		shear	tension		shear	tension		shear	tension		shear	tension		shear
spacing $s_1$ (mm)	$N^*_{Rd,p}$	$N^*_{Rd,c}$	$V^*_{Rd,c}$	$N^*_{Rd,p}$	$N^*_{Rd,c}$	$V^*_{Rd,c}$	$N^*_{Rd,p}$	$N^*_{Rd,c}$	$V^*_{Rd,c}$	$N^*_{Rd,p}$	$N^*_{Rd,c}$	$V^*_{Rd,c}$	$N^*_{Rd,p}$	$N^*_{Rd,c}$	$V^*_{Rd,c}$
70	NOT CRITICAL	14.6	9.9	NOT CRITICAL	16.0	13.0	NOT CRITICAL	17.4	15.6	NOT CRITICAL	20.4	19.3	NOT CRITICAL	24.4	23.9
100		15.4	10.9		16.8	14.1		18.3	16.7		21.4	20.4		25.6	25.0
150		16.6	12.7		18.2	16.0		19.8	18.7		23.1	22.3		27.7	26.8
200		17.9	14.4		19.5	17.9		21.2	20.6		24.9	24.1		29.8	28.6
250		19.1	14.8		20.9	19.8		22.7	22.6		26.6	26.0		31.9	30.4
300		20.4	14.8		22.2	20.6		24.2	24.5		28.3	27.8		33.9	32.1

ANCHOR <b>M12</b>	Edge C (mm)														
	80			100			150			200			250		
	tension		shear	tension		shear	tension		shear	tension		shear	tension		shear
spacing $s_1$ (mm)	$N^*_{Rd,p}$	$N^*_{Rd,c}$	$V^*_{Rd,c}$	$N^*_{Rd,p}$	$N^*_{Rd,c}$	$V^*_{Rd,c}$	$N^*_{Rd,p}$	$N^*_{Rd,c}$	$V^*_{Rd,c}$	$N^*_{Rd,p}$	$N^*_{Rd,c}$	$V^*_{Rd,c}$	$N^*_{Rd,p}$	$N^*_{Rd,c}$	$V^*_{Rd,c}$
80	-	-	-	NOT CRITICAL	19.9	16.0	NOT CRITICAL	23.4	22.2	NOT CRITICAL	27.1	27.2	NOT CRITICAL	31.1	32.2
100	-	-	-		20.4	16.9		24.0	23.0		27.9	28.0		31.9	32.9
150	NOT CRITICAL	20.3	15.4		21.7	19.0		25.5	25.1		29.6	30.0		34.0	34.9
200		21.5	17.4		23.0	21.1		27.1	27.2		31.4	32.0		36.0	36.8
250		22.7	18.9		24.3	23.2		28.6	29.3		33.2	34.0		38.1	38.8
300		23.9	18.9		25.7	25.3		30.1	31.3		35.0	36.0		40.1	40.7

ANCHOR <b>M16</b>	Edge C (mm)														
	100			150			200			250			300		
	tension		shear	tension		shear	tension		shear	tension		shear	tension		shear
spacing s1 (mm)	N*Rd,p	N*Rd,c	V*Rd,c	N*Rd,p	N*Rd,c	V*Rd,c	N*Rd,p	N*Rd,c	V*Rd,c	N*Rd,p	N*Rd,c	V*Rd,c	N*Rd,p	N*Rd,c	V*Rd,c
100	NOT CRITICAL	28.6	18.8	NOT CRITICAL	32.9	29.1	NOT CRITICAL	37.5	36.6	NOT CRITICAL	42.3	42.7	NOT CRITICAL	47.4	48.8
150		30.2	21.2		34.7	31.7		39.5	39.2		44.6	45.2		50.0	51.3
200		31.7	23.6		36.5	34.3		41.6	41.8		47.0	47.8		52.6	53.7
250		33.3	25.9		38.3	37.0		43.6	44.4		49.3	50.3		55.2	56.2
300		34.9	28.3		40.1	39.6		45.7	47.0		51.6	52.8		57.8	58.6
350		36.4	28.3		41.9	42.3		47.7	49.6		53.9	55.3		60.4	61.1

ANCHOR <b>M20</b>	Edge C (mm)														
	120			150			200			250			350		
	tension		shear	tension		shear	tension		shear	tension		shear	tension		shear
spacing s1 (mm)	N*Rd,p	N*Rd,c	V*Rd,c	N*Rd,p	N*Rd,c	V*Rd,c	N*Rd,p	N*Rd,c	V*Rd,c	N*Rd,p	N*Rd,c	V*Rd,c	N*Rd,p	N*Rd,c	V*Rd,c
120	-	-	-	NOT CRITICAL	40.3	32.8	NOT CRITICAL	44.6	43.3	NOT CRITICAL	49.2	50.1	NOT CRITICAL	58.8	63.5
150	-	-	-		41.3	34.5		45.7	45.1		50.4	51.8		60.3	65.1
200	NOT CRITICAL	40.2	30.4		42.9	37.4		47.5	48.2		52.3	54.7		62.6	67.8
250		41.8	33.1		44.5	40.2		49.3	51.2		54.3	57.6		65.0	70.5
300		43.3	35.8		46.2	43.1		51.1	54.2		56.3	60.5		67.4	73.2
350		44.8	38.6		47.8	46.0		52.9	57.2		58.3	63.3		69.8	75.9

## Four anchors

**Table 2:** One edge influence – cracked concrete

Design Data:  $f_{c,cyl}=32$  MPa– Cracked Concrete

Anchor size	M8	M10	M12	M16	M20
Typical embedment depth $h_{ef}$ [mm]	70	90	110	145	180
Min Slab depth	130	150	170	245	280

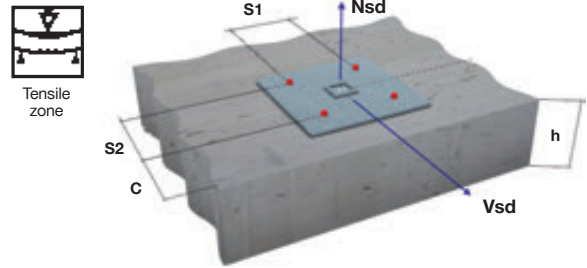

ANCHOR <b>M8</b>	Edge C (mm)														
	50			80			100			150			200		
	tension		shear	tension		shear	tension		shear	tension		shear	tension		shear
spacing $s1=s2$ (mm)	$N^*_{Rd,p}$	$N^*_{Rd,c}$	$V^*_{Rd,c}$	$N^*_{Rd,p}$	$N^*_{Rd,c}$	$V^*_{Rd,c}$	$N^*_{Rd,p}$	$N^*_{Rd,c}$	$V^*_{Rd,c}$	$N^*_{Rd,p}$	$N^*_{Rd,c}$	$V^*_{Rd,c}$	$N^*_{Rd,p}$	$N^*_{Rd,c}$	$V^*_{Rd,c}$
50	NOT CRITICAL	12.6	5.8	NOT CRITICAL	14.9	9.8	NOT CRITICAL	16.5	12.0	NOT CRITICAL	21.0	16.2	32.8	23.3	20.4
100		16.8	7.3		19.5	11.5		21.5	13.7		26.7	17.9	51.2	29.5	22.0
150		21.5	8.7		24.8	13.2		27.0	15.4		33.2	19.5	73.7	36.4	23.6
200		26.8	8.7		30.6	14.9		33.3	17.1		40.4	21.1	73.7	44.1	25.2
250		32.7	8.7		37.1	16.3		40.1	18.8		48.3	22.7	73.7	52.5	26.7
300		39.2	8.7		44.2	16.3		47.6	20.5		56.9	24.4	73.7	61.7	28.3

ANCHOR <b>M10</b>	Edge C (mm)														
	60			80			100			150			200		
	tension		shear	tension		shear	tension		shear	tension		shear	tension		shear
spacing $s1=s2$ (mm)	$N^*_{Rd,p}$	$N^*_{Rd,c}$	$V^*_{Rd,c}$	$N^*_{Rd,p}$	$N^*_{Rd,c}$	$V^*_{Rd,c}$	$N^*_{Rd,p}$	$N^*_{Rd,c}$	$V^*_{Rd,c}$	$N^*_{Rd,p}$	$N^*_{Rd,c}$	$V^*_{Rd,c}$	$N^*_{Rd,p}$	$N^*_{Rd,c}$	$V^*_{Rd,c}$
60	-	-	-	NOT CRITICAL	17.7	11.0	NOT CRITICAL	19.1	14.2	NOT CRITICAL	23.0	18.9	NOT CRITICAL	27.1	23.6
100	NOT CRITICAL	19.3	9.4		20.8	12.5		22.4	15.8		26.6	20.4		31.2	25.0
150		23.4	11.1		25.1	14.3		26.9	17.8		31.6	22.3		36.8	26.8
200		27.8	12.1		29.7	16.2		31.8	19.7		37.1	24.1		42.8	28.6
250		32.6	12.1		34.8	17.6		37.0	21.7		42.9	26.0		49.2	30.4
300		37.8	12.1		40.2	17.6		42.7	23.7		49.2	27.8		56.2	32.1

ANCHOR <b>M12</b>	Edge C (mm)														
	80			100			150			200			250		
	tension		shear	tension		shear	tension		shear	tension		shear	tension		shear
spacing $s1=s2$ (mm)	$N^*_{Rd,p}$	$N^*_{Rd,c}$	$V^*_{Rd,c}$	$N^*_{Rd,p}$	$N^*_{Rd,c}$	$V^*_{Rd,c}$	$N^*_{Rd,p}$	$N^*_{Rd,c}$	$V^*_{Rd,c}$	$N^*_{Rd,p}$	$N^*_{Rd,c}$	$V^*_{Rd,c}$	$N^*_{Rd,p}$	$N^*_{Rd,c}$	$V^*_{Rd,c}$
80	-	-	-	NOT CRITICAL	23.5	16.0	NOT CRITICAL	27.2	22.2	NOT CRITICAL	31.1	27.2	NOT CRITICAL	35.3	32.2
100	NOT CRITICAL	-	-		25.1	16.9		28.9	23.0		33.0	28.0		37.3	32.9
150		27.5	15.4		29.1	19.0		33.3	25.1		37.8	30.0		42.6	34.9
200		31.7	17.4		33.5	21.1		38.1	27.2		43.0	32.0		48.2	36.8
250		36.2	18.9		38.1	23.2		43.1	29.3		48.5	34.0		54.1	38.8
300		41.0	18.9		43.1	25.3		48.5	31.3		54.3	36.0		60.4	40.7

ANCHOR <b>M16</b>	Edge C (mm)														
	100			150			200			250			300		
	tension		shear	tension		shear	tension		shear	tension		shear	tension		shear
spacing s1=s2 (mm)	N*Rd,p	N*Rd,c	V*Rd,c	N*Rd,p	N*Rd,c	V*Rd,c	N*Rd,p	N*Rd,c	V*Rd,c	N*Rd,p	N*Rd,c	V*Rd,c	N*Rd,p	N*Rd,c	V*Rd,c
100	NOT CRITICAL	34.3	18.8	NOT CRITICAL	38.8	29.1	NOT CRITICAL	43.7	36.6	NOT CRITICAL	48.8	42.7	NOT CRITICAL	54.1	48.8
150		39.1	21.2		44.0	31.7		49.3	39.2		54.8	45.2		60.6	51.3
200		44.2	23.6		49.6	34.3		55.2	41.8		61.2	47.8		67.4	53.7
250		49.7	25.9		55.4	37.0		61.5	44.4		67.9	50.3		74.7	56.2
300		55.4	28.3		61.6	39.6		68.2	47.0		75.0	52.8		82.2	58.6
350		61.5	28.3		68.1	42.3		75.1	49.6		82.5	55.3		90.2	61.1

ANCHOR <b>M20</b>	Edge C (mm)														
	120			150			200			250			350		
	tension		shear	tension		shear	tension		shear	tension		shear	tension		shear
spacing s1=s2 (mm)	N*Rd,p	N*Rd,c	V*Rd,c	N*Rd,p	N*Rd,c	V*Rd,c	N*Rd,p	N*Rd,c	V*Rd,c	N*Rd,p	N*Rd,c	V*Rd,c	N*Rd,p	N*Rd,c	V*Rd,c
120	-	-	-	NOT CRITICAL	47.1	32.8	NOT CRITICAL	51.7	43.3	NOT CRITICAL	56.5	50.1	NOT CRITICAL	66.6	63.5
150	-	-	-		50.0	34.5		54.8	45.1		59.7	51.8		70.2	65.1
200	NOT CRITICAL	52.1	30.4		55.0	37.4		60.1	48.2		65.3	54.7		76.5	67.8
250		57.2	33.1		60.3	40.2		65.6	51.2		71.2	57.6		83.0	70.5
300		62.5	35.8		65.8	43.1		71.4	54.2		77.3	60.5		89.7	73.2
350		68.0	38.6		71.5	46.0		77.5	57.2		83.7	63.3		96.8	75.9

## Materials

### Mechanical properties of HIT-Z and HIT-Z-R

Anchor size		M8	M10	M12	M16	M20
Nominal tensile strength $f_{uk}$	HIT-Z	650	650	650	610	595
	HIT-Z-R					
Yield strength $f_{yk}$	HIT-Z	520	520	520	490	480
	HIT-Z-R					
Stressed cross-section $A_s$	HIT-Z	36.6	58.0	84.3	157	245
Moment of resistance $W$	HIT-Z	31.9	62.5	109.7	278	542

## Material quality

Part	Material
HIT-Z	C-steel cold formed, steel galvanized $\geq 5\mu\text{m}$
HIT-Z-R	stainless steel cold formed, A4

## Anchor dimensions

Anchor size		M8	M10	M12	M16	M20
Length of anchor	min $l$	80	95	105	155	215
	max $l$	120	160	196	240	250
Helix length	$l_{\text{Helix}}$	50	60	60	96	100

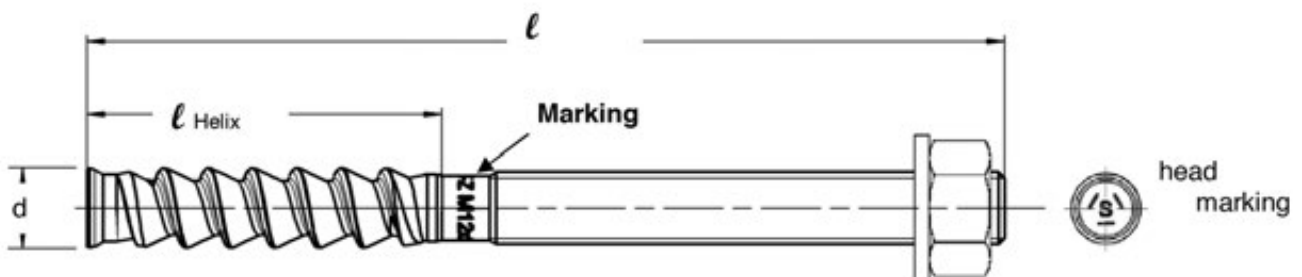

## Installation equipment

Anchor size	M8	M10	M12	M16	M20
Rotary hammer	TE 2 - TE 40			TE 40 - TE 70	

## Setting instructions

### Bore hole drilling

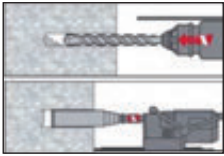

**Pre-setting:** Drill hole to the required drilling depth with a hammer drill set in rotation-hammer mode using an appropriately sized carbide drill bit. Diamond coring is permissible when diamond core drilling machine and the corresponding core bit are used.

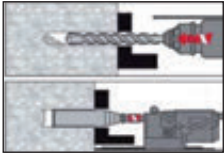

**Through-setting:** Drill hole through the clearance hole in the fixture to the required drilling depth with a hammer drill set in rotation-hammer mode using an appropriately sized carbide drill bit. Diamond coring is permissible when diamond core drilling machine and the corresponding core bit are used.

### Bore hole cleaning

a) No cleaning required for hammer drilled boreholes.

b) Hole flushing and evacuation for wet-drilled diamond cored holes or flooded holes

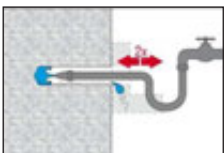

Flush 2 times from the back of the hole over the hole length.

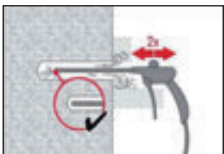

Blow 2 times the hole with oil-free compressed air (min. 6 bar at 6 m<sup>3</sup>/h) to evacuate the water.

### Check of setting depth and compress of the drilling dust

Check of setting depth and compress of the drilling dust

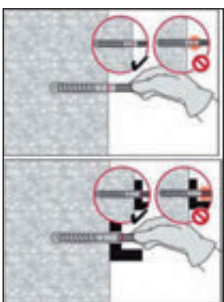

Mark the element and check the setting depth and compress the drilling dust. The element has to fit in the hole until the required embedment depth.

If it is not possible to compress the dust, remove the dust in the drill hole or drill deeper.

a) When drilling downward with non-cleaning the required drilling depths can vary due to accumulation of dust in the hole.



## Setting instructions

### Injection preparation

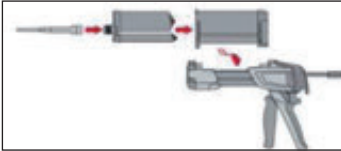

Tightly attach new Hilti mixing nozzle HIT-RE-M to foil pack manifold (snug fit). Do not modify the mixing nozzle. Observe the instruction for use of the dispenser. Check foil pack holder for proper function. Do not use damaged foil packs / holders. Swing foil pack holder with foil pack into HIT dispenser.

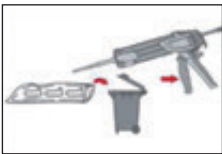

Discard initial adhesive. The foil pack opens automatically as dispensing is initiated. Depending on the size of the foil pack an initial amount of adhesive has to be discarded.

Discard quantities are:

2 strokes for 330 ml foil pack,

3 strokes for 500 ml foil pack,

### Inject adhesive from the back of the borehole without forming air voids

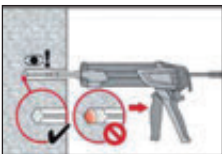

Inject the adhesive starting at the back of the hole, slowly withdrawing the mixer with each trigger pull.

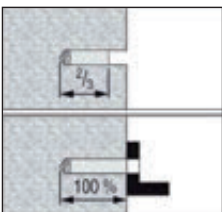

Fill holes approximately 2/3 full for Pre-setting and 100% full for throughsetting, or as required to ensure that the annular gap between the anchor and the concrete is completely filled with adhesive along the embedment length.



After injection is completed, depressurize the dispenser by pressing the release trigger. This will prevent further adhesive discharge from the mixer.

### Overhead installation

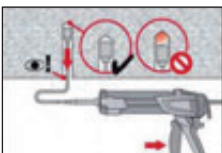

For overhead installation the injection is only possible with the aid of extensions and piston plugs. Assemble HIT-RE-M mixer, extension(s) and appropriately piston plug HIT-SZ. Insert piston plug to back of the hole and inject adhesive. During injection the piston plug will be naturally extruded out of the bore hole by the adhesive pressure

## Setting instructions

### Setting the element

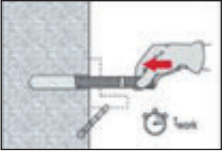

Before use, verify that the element is dry and free of oil and other contaminants. Set element to the required embedment depth until working time  $t_{work}$  has elapsed. After setting the element the annular gap between the anchor and the fixture (through-setting) or concrete (pre-setting) has to be completely filled with mortar.

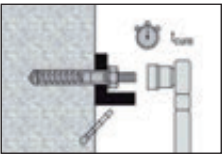

After required curing time  $t_{cure}$  remove excess mortar. Apply indicated torque moment to activate anchor functioning principles. The anchor can be loaded.

For detailed information on installation see instruction for use given with the package of the product.



### Setting details

Anchor size		M8	M10	M12	M16	M20
Nominal diameter of drill bit	$d_0$ [mm]	10	12	14	18	22
Effective embedment and drill hole depth range a) for HIT-V	$h_{nom,min}$ [mm]	60	60	60	96	100
	$h_{nom,max}$ [mm]	100	120	150	200	220
Minimum base material thickness	$h_{min}$ [mm]	$h_{nom} + 60$			$h_{nom} + 100$	
Pre-setting: Diameter of clearancehole in the fixture	$d_f \leq$ [mm]	9	12	14	18	22
Through-setting: Diameter of clearance hole in the fixture	$d_f \leq$ [mm]	11	14	16	20	24
Torque moment	$T_{max}$ [Nm]	10	25	40	80	150

### Working time, curing time

Temperature of the base material	HIT-HY 200-R	
	Working time in which anchor can be inserted and adjusted $t_{work}$	Curing time before anchor can be loaded $t_{cure}$
5 °C	1 hour	3 hour
6 °C to 10 °C	40 min	2 hour
11 °C to 20 °C	15 min	1 hour
21 °C to 30 °C	9 min	1 hour
31 °C to 40 °C	6 min	1 hour

## Hilti HIT-HY 200 with rebar

Injection Mortar System	Benefits
 <p>Hilti HIT-HY 200-R 500 ml foil pack (also available as 330 ml foil pack)</p>	<ul style="list-style-type: none"> <li>■ Suitable for non-cracked and cracked concrete C 20/25 to C 50/60</li> <li>■ Suitable for dry and water saturated concrete</li> <li>■ High loading capacity, excellent handling and fast curing</li> <li>■ Small edge distance and anchor spacing possible</li> <li>■ Large diameter applications</li> <li>■ Max In service temperature range up to 120°C short term/ 72°C long term</li> <li>■ Manual cleaning for borehole diameter up to 20mm and hef ≤ 10d for non-cracked concrete only</li> </ul>
 <p>Static mixer</p>	
 <p>Rebar BSt 500 S</p>	



Concrete



Tensile zone



Small edge distance & spacing



Variable embedment depth



European Technical Approval



CE conformity



PROFIS anchor design software



SAFEset approved automatic cleaning

### Approvals / certificates

Description	Authority / Laboratory	No. / date of issue
European technical approval <sup>a)</sup>	DIBt, Berlin	ETA-12/0084 / 2013-06-20 (Hilti HIT-HY 200-R)

a) All data given in this section according ETA-11/0493 and ETA-12/0084, issue 2013-06-20.

### Service temperature range

Hilti HIT-HY 200 injection mortar may be applied in the temperature ranges given below. An elevated base material temperature may lead to a reduction of the design bond resistance.

Temperature range	Base material temperature	Maximum long term base material temperature	Maximum short term base material temperature
Temperature range I	-40 °C to +40 °C	+24 °C	+40 °C
Temperature range II	-40 °C to +80 °C	+50 °C	+80 °C
Temperature range III	-40 °C to +120 °C	+72 °C	+120 °C

#### Max short term base material temperature

Short-term elevated base material temperatures are those that occur over brief intervals, e.g. as a result of diurnal cycling.

#### Max long term base material temperature

Long-term elevated base material temperatures are roughly constant over significant periods of time

## Design process for typical anchor layouts

The design values in the tables are obtained from Profis V2.2.1 in compliance with the design method according to EOTA TR 029. Design resistance according to data given in ETA-12/0084, issue 2013-06-20.

- Influence of concrete strength
- Influence of edge distance
- Influence of spacing

The design method is based on the following simplification:

- No different loads are acting on individual anchors (no eccentricity)

The values are valid for the anchor configuration.

For more complex fastening applications please use the anchor design software PROFIS Anchor.

### STEP 1: TENSION LOADING

The design tensile resistance  $N_{Rd}$  is the lower of:

- Combined pull-out and concrete cone resistance

$$N_{Rd,p} = f_{B,p} \cdot N^*_{Rd,p}$$

$N^*_{Rd,p}$  is obtained from the relevant design tables

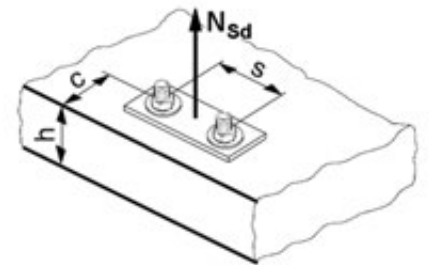

$f_{B,p}$  influence of concrete strength on combined pull-out and concrete cone resistance

Concrete Strengths $f'_{c,cyl}$ (MPa)	20	25	32	40	50
$f_{B,p}$	1.00	1.00	1.00	1.00	1.00

- Concrete cone or concrete splitting resistance

$$N_{Rd,c} = f_B \cdot N^*_{Rd,c}$$

$N^*_{Rd,c}$  is obtained from the relevant design tables

$f_B$  influence of concrete strength on concrete cone resistance

Concrete Strengths $f'_{c,cyl}$ (MPa)	20	25	32	40	50
$f_B$	0.79	0.87	1.00	1.11	1.22

- Design steel resistance  $N_{Rd,s}$

			Data according ETA-11/0493 and ETA-12/0084, issue 2013-06-20								
Anchor size			Ø8	Ø10	Ø12	Ø14	Ø16	Ø20	Ø24	Ø28	Ø32
$N_{Rd,s}$	BSt 500 S	[kN]	20.0	30.7	44.3	60.7	79.3	123.6	177.8	242.1	315.7

$$N_{Rd} = \min \{ N_{Rd,p}, N_{Rd,c}, N_{Rd,s} \}$$

**CHECK  $N_{Rd} \geq N_{Sd}$**

## STEP 2: SHEAR LOADING

The design shear resistance  $V_{Rd}$  is the lower of:

### ■ Design Concrete Edge Resistance

$$V_{Rd,c} = f_B \cdot V^*_{Rd,c} \cdot \psi_{re,V}$$

$V^*_{Rd,c}$  is obtained from the relevant design table

The factor  $\psi_{re,V}$  takes account of the effect of the type of reinforcement used in cracked concrete.

$\psi_{re,V} = 1.0$  anchorage in non-cracked concrete

$\psi_{re,V} = 1.0$  anchorage in cracked concrete without edge reinforcement

$\psi_{re,V} = 1.2$  anchorage in cracked concrete with straight edge reinforcement ( $\geq \text{Ø}12$  mm)

$\psi_{re,V} = 1.4$  anchorage in cracked concrete with edge reinforcement and closely spaced stirrups ( $a \leq 100$  mm)

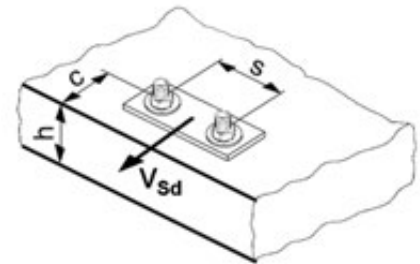

### $f_B$ influence of concrete strength

Concrete Strengths $f'_{c,cyl}$ (MPa)	20	25	32	40	50
$f_B$	0.79	0.87	1.00	1.11	1.22

#### Shear load acting parallel to edge:

These tables are for a single free edge only

#### 2 anchors:

For shear loads acting parallel to this edge, the concrete resistance  $V^*_{Rd,c}$  can be multiplied by the factor = 2.5

#### 4 anchors:

For shear loads acting parallel to the edge - the anchor row closest to the edge is checked to resist half the total design load. To obtain the concrete resistance use the corresponding 2 anchor configuration  $V^*_{Rd,c}$  and multiply by the factor = 2.5

### ■ Design steel resistance $V_{Rd,s}$

		Data according ETA-11/0493 and ETA-12/0084, issue 2013-06-20								
Anchor size		Ø8	Ø10	Ø12	Ø14	Ø16	Ø20	Ø24	Ø28	Ø32
$V_{Rd,s}$	BSt 500 S [kN]	9.3	14.7	20.7	28.0	36.7	57.3	83.0	112.7	147.3

$$V_{Rd} = \min \{ V_{Rd,c}, V_{Rd,s} \}$$

$$\text{CHECK } V_{Rd} \geq V_{Sd}$$

## STEP 3: COMBINED TENSION AND SHEAR LOADING

The following equations must be satisfied:

$$N_{Sd}/N_{Rd} + V_{Sd}/V_{Rd} \leq 1.2$$

and

$$N_{Sd}/N_{Rd} \leq 1, V_{Sd}/V_{Rd} \leq 1$$

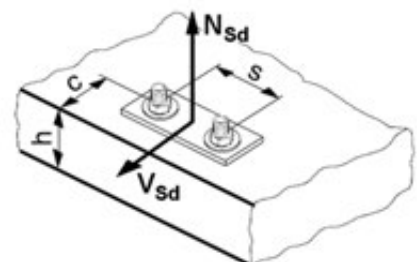

## Precalculated table values – design resistance values

### General:

The following tables provide the total ultimate limit state design resistance for the configurations.

All tables are based upon:

- correct setting (See setting instruction)
- non cracked and cracked concrete –  $f_{c,cyl} = 32 \text{ MPa}$
- temperature range I (see service temperature range)
- base material thickness, as specified in the table
- Three typical embedment depths, as specified in the tables

The following tables give design values for typical embedment depths. The latest version of the Hilti software Profis allows the engineer to optimise their design by varying the embedment depth according to the applied loads to achieve an economical solution every time.

The anchor design software program Profis can be download from the Hilti Australia website, [www.hilti.com.au](http://www.hilti.com.au).

## Single anchor - uncracked concrete - no edge and spacing influences

### Embedment 1

Design Resistance $f_{c,cyl} - 32\text{Mpa}$										
Rebar size		Ø8	Ø10	Ø12	Ø16	Ø20	Ø24	Ø28	Ø32	
Embedment depth	[mm]	60	60	72	96	120	144	168	192	
Base material thickness	[mm]	100	100	104	136	170	210	238	272	
Tensile Single anchor no edge										
Pull-out	$N_{Rd,p}^*$	[kN]	12.0	15.1	21.7	38.6	60.3	73.6	118.2	154.4
Concrete	$N_{Rd,c}^*$	[kN]	19.8	19.8	26.0	40.1	56.0	90.4	92.7	113.3
Shear Single anchor no edge										
Shear	$V_{Rd,s}$	[kN]	9.3	14.7	20.7	36.7	57.3	83.0	112.7	147.3

### Embedment 2



Design Resistance $f_{c,cyl} - 32\text{Mpa}$										
Rebar size		Ø8	Ø10	Ø12	Ø16	Ø20	Ø24	Ø28	Ø32	
Embedment depth	[mm]	80	90	110	145	170	210	270	300	
Base material thickness	[mm]	110	120	142	185	220	274	340	380	
Tensile Single anchor no edge										
Pull-out	$N_{Rd,p}^*$	[kN]	16.1	22.6	33.2	58.3	85.4	132.0	190.0	241.3
Concrete	$N_{Rd,c}^*$	[kN]	30.4	36.3	49.1	74.4	94.4	129.6	188.9	221.3
Shear Single anchor no edge										
Shear	$V_{Rd,s}$	[kN]	9.3	14.7	20.7	36.7	57.3	83.0	112.7	147.3

### Embedment 3



Design Resistance $f_{c,cyl} - 32\text{Mpa}$										
Rebar size		Ø8	Ø10	Ø12	Ø16	Ø20	Ø24	Ø28	Ø32	
Embedment depth	[mm]	96	120	144	192	240	288	336	384	
Base material thickness	[mm]	126	150	176	232	290	348	406	464	
Tensile Single anchor no edge										
Pull-out	$N_{Rd,p}^*$	[kN]	19.3	30.2	43.4	77.2	120.6	188.5	236.4	308.8
Concrete	$N_{Rd,c}^*$	[kN]	40.0	56.0	73.6	113.3	158.3	221.3	262.3	320.4
Shear Single anchor no edge										
Shear	$V_{Rd,s}$	[kN]	9.3	14.7	20.7	36.7	57.3	83.0	112.7	147.3

## Single anchor - uncracked concrete - minimum edge distance



### Embedment 1

Design Resistance $f_{c,cyl}$ - 32Mpa										
Rebar size		Ø8	Ø10	Ø12	Ø16	Ø20	Ø24	Ø28	Ø32	
Embedment depth [mm]		60	60	72	96	120	144	168	192	
Base material thickness [mm]		100	100	104	136	170	210	238	272	
Edge Dist $c = c_{min}$ [mm]		40	50	60	80	100	125	140	160	
Tensile Single anchor min edge										
	Pull-out	$N_{Rd,p}^*$ [kN]	7.3	10.2	14.6	26.0	40.7	62.4	79.7	104.1
	Concrete	$N_{Rd,c}^*$ [kN]	11.5	12.9	15.2	23.1	32.4	44.3	53.6	66.5
Shear Single anchor no edge										
	Shear (without lever arm)	$V_{Rd,c}^*$ [kN]	4.4	6.2	8.4	13.7	19.9	28.6	35.0	43.8

### Embedment 2

Design Resistance $f_{c,cyl}$ - 32Mpa										
Rebar size		Ø8	Ø10	Ø12	Ø16	Ø20	Ø24	Ø28	Ø32	
Embedment depth [mm]		80	90	110	145	170	210	270	300	
Base material thickness [mm]		110	120	142	185	220	270	340	380	
Edge Dist $c = c_{min}$ [mm]		40	50	60	80	100	125	140	160	
Tensile Single anchor min edge										
	Pull-out	$N_{Rd,p}^*$ [kN]	9.2	12.9	18.9	33.3	48.8	75.5	108.5	137.8
	Concrete	$N_{Rd,c}^*$ [kN]	14.5	17.6	23.5	35.8	46.2	63.8	89.3	106.5
Shear Single anchor no edge										
	Shear (without lever arm)	$V_{Rd,c}^*$ [kN]	4.7	6.7	9.3	14.5	21.7	31.6	40.0	49.8

### Embedment 3

Design Resistance $f_{c,cyl}$ - 32Mpa										
Rebar size		Ø8	Ø10	Ø12	Ø16	Ø20	Ø24	Ø28	Ø32	
Embedment depth [mm]		96	120	144	192	240	288	336	384	
Base material thickness [mm]		126	150	176	232	290	348	406	464	
Edge Dist $c = c_{min}$ [mm]		40	50	60	80	100	125	140	160	
Tensile Single anchor min edge										
	Pull-out	$N_{Rd,p}^*$ [kN]	11.0	17.2	24.8	44.0	68.9	107.6	135.0	176.4
	Concrete	$N_{Rd,c}^*$ [kN]	18.0	25.0	32.9	50.7	70.8	99.0	117.3	144.6
Shear Single anchor no edge										
	Shear (without lever arm)	$V_{Rd,c}^*$ [kN]	4.9	7.2	9.9	16.3	23.9	35.2	42.8	53.9

## 2 anchors - uncracked concrete - minimum spacing influence

### Embedment 1

Design Resistance $f_{c,cyl} - 32\text{Mpa}$				Ø8	Ø10	Ø12	Ø16	Ø20	Ø24	Ø28	Ø32
Rebar size				Ø8	Ø10	Ø12	Ø16	Ø20	Ø24	Ø28	Ø32
Embedment depth	[mm]			60	60	72	96	120	144	168	192
Base material thickness	[mm]			100	100	104	136	170	210	238	272
Spacing dist $s=s_{min}$	[mm]			40	50	60	80	100	120	140	160
Tensile $N_{Rd}$											
	Pull-out	$N_{Rd,p}^*$	[kN]	16.4	20.5	29.0	49.8	77.1	116.6	151.1	197.3
	Concrete	$N_{Rd,c}^*$	[kN]	23.9	25.0	31.4	48.2	67.4	90.3	111.6	138.4
Shear $V_{Rd}$											
$V_{Rd,s}$	steel (per anchor)		[kN]	9.3	14.7	20.7	36.7	57.3	83.0	112.7	147.3
$V_{Rd,c}^*$	pryout		[kN]	N/A				143.1	189.7	237.0	289.5

### Embedment 2

Design Resistance $f_{c,cyl} - 32\text{Mpa}$				Ø8	Ø10	Ø12	Ø16	Ø20	Ø24	Ø28	Ø32
Rebar size				Ø8	Ø10	Ø12	Ø16	Ø20	Ø24	Ø28	Ø32
Embedment depth	[mm]			80	90	110	145	170	210	270	300
Base material thickness	[mm]			110	120	142	185	220	270	340	380
Spacing dist $s=s_{min}$	[mm]			40	50	60	80	100	125	140	160
Tensile $N_{Rd}$											
	Pull-out	$N_{Rd,p}^*$	[kN]	22.0	30.2	43.7	74.7	105.5	158.1	227.5	289.0
	Concrete	$N_{Rd,c}^*$	[kN]	34.1	41.0	55.1	83.4	106.7	146.7	210.6	250.0
Shear $V_{Rd}$											
$V_{Rd,s}$	(per anchor)		[kN]	9.3	14.7	20.7	36.7	57.3	83.0	112.7	147.3

### Embedment 3

Design Resistance $f_{c,cyl} - 32\text{Mpa}$				Ø8	Ø10	Ø12	Ø16	Ø20	Ø24	Ø28	Ø32
Rebar size				Ø8	Ø10	Ø12	Ø16	Ø20	Ø24	Ø28	Ø32
Embedment depth	[mm]			96	120	144	192	240	288	336	384
Base material thickness	[mm]			126	150	176	232	290	348	406	464
Spacing dist $s=s_{min}$	[mm]			40	50	60	80	100	125	140	160
Tensile $N_{Rd}$											
	Pull-out	$N_{Rd,p}^*$	[kN]	26.6	41.1	58.5	101.7	155.5	236.5	292.2	373.9
	Concrete	$N_{Rd,c}^*$	[kN]	43.8	61.1	80.3	123.7	172.9	241.7	286.4	353.0
Shear $V_{Rd}$											
$V_{Rd,s}$	(per anchor)		[kN]	9.3	14.7	20.7	36.7	57.3	83.0	112.7	147.3



## Single anchor - cracked concrete - no edge and spacing influences



Tensile zone

### Embedment 1

Design Resistance $f_{c,cyl} - 32\text{Mpa}$								
Rebar size		Ø10	Ø12	Ø16	Ø20	Ø24	Ø28	Ø32
Embedment depth [mm]		60	72	96	120	144	168	192
Base material thickness [mm]		100	104	136	170	210	238	272
Tensile Single anchor no edge								
Pull-out	$N_{Rd,p}^*$ [kN]	6.3	12.7	22.5	35.1	52.8	69.0	90.0
Concrete	$N_{Rd,c}^*$ [kN]	14.1	18.5	28.5	39.9	52.4	66.1	80.8
Shear $V_{Rd}$								
$V_{Rd,s}$ steel (per anchor)	[kN]	14.7	20.7	36.7	57.3	83.0	112.7	147.3
$V_{Rd,c}^*$ pryout	[kN]	12.6	25.3	45.0	70.4	104.9	132.2	161.5

### Embedment 2

Design Resistance $f_{c,cyl} - 32\text{Mpa}$								
Rebar size		Ø10	Ø12	Ø16	Ø20	Ø24	Ø28	Ø32
Embedment depth [mm]		90	110	145	170	210	270	300
Base material thickness [mm]		120	142	185	220	274	340	380
Tensile Single anchor no edge								
Pull-out	$N_{Rd,p}^*$ [kN]	9.4	19.4	34.0	49.8	77.0	110.8	140.7
Concrete	$N_{Rd,c}^*$ [kN]	25.9	35.0	53.0	67.3	92.4	134.7	157.7
Shear Single anchor no edge								
$V_{Rd,s}$	[kN]	14.7	20.7	36.7	57.3	83.0	112.7	147.3

### Embedment 3

Design Resistance $f_{c,cyl} - 32\text{Mpa}$								
Rebar size		Ø10	Ø12	Ø16	Ø20	Ø24	Ø28	Ø32
Embedment depth [mm]		120	144	192	240	288	336	384
Base material thickness [mm]		150	176	232	290	348	406	464
Tensile Single anchor no edge								
Pull-out	$N_{Rd,p}^*$ [kN]	12.6	25.3	45.0	70.4	105.5	137.9	180.2
Concrete	$N_{Rd,c}^*$ [kN]	39.9	52.4	80.8	112.8	148.4	187.0	228.4
Shear Single anchor no edge								
$V_{Rd,s}$	[kN]	14.7	20.7	36.7	57.3	83.0	112.7	147.3

## Single - cracked concrete - minimum edge distance



Tensile zone

### Embedment 1

Design Resistance $f_{c,cyl} - 32\text{Mpa}$										
Rebar size		Ø10	Ø12	Ø16	Ø20	Ø24	Ø28	Ø32		
Embedment depth	[mm]	60	72	96	120	144	168	192		
Base material thickness	[mm]	100	104	136	170	210	238	272		
Edge Dist $c = c_{min}$	[mm]	50	60	80	100	125	140	160		
Tensile Single anchor min edge										
	Pull-out	$N_{Rd,p}^*$	[kN]	4.2	8.5	15.2	23.7	36.4	46.5	60.7
	Concrete	$N_{Rd,c}^*$	[kN]	9.2	10.8	16.5	23.1	31.6	38.2	47.4
Shear Single anchor min edge										
	Shear (without lever arm)	$V_{Rd,c}^*$	[kN]	4.4	6.0	9.7	14.1	20.3	24.8	31.0

### Embedment 2

Design Resistance $f_{c,cyl} - 32\text{Mpa}$										
Rebar size		Ø10	Ø12	Ø16	Ø20	Ø24	Ø28	Ø32		
Embedment depth	[mm]	90	110	145	170	210	270	300		
Base material thickness	[mm]	120	142	185	220	270	340	380		
Edge Dist $c = c_{min}$	[mm]	50	60	80	100	125	140	160		
Tensile Single anchor min edge										
	Pull-out	$N_{Rd,p}^*$	[kN]	5.4	11.1	19.4	28.4	44.0	63.3	80.4
	Concrete	$N_{Rd,c}^*$	[kN]	12.6	16.8	22.5	33.0	45.5	63.7	75.9
Shear Single anchor min edge										
	Shear (without lever arm)	$V_{Rd,c}^*$	[kN]	4.8	6.6	10.3	15.4	22.4	28.3	35.3

### Embedment 3

Design Resistance $f_{c,cyl} - 32\text{Mpa}$										
Rebar size		Ø10	Ø12	Ø16	Ø20	Ø24	Ø28	Ø32		
Embedment depth	[mm]	120	144	192	240	288	336	384		
Base material thickness	[mm]	150	176	232	290	348	406	464		
Edge Dist $c = c_{min}$	[mm]	50	60	80	100	125	140	160		
Tensile Single anchor min edge										
	Pull-out	$N_{Rd,p}^*$	[kN]	7.2	14.5	25.7	40.2	60.3	78.8	102.9
	Concrete	$N_{Rd,c}^*$	[kN]	17.8	23.5	36.1	50.5	67.0	83.6	103.0
Shear Single anchor min edge										
	Shear (without lever arm)	$V_{Rd,c}^*$	[kN]	5.1	7.0	11.5	17.0	24.6	30.3	38.2

## 2 anchors - cracked concrete - minimum spacing influence



Tensile zone

### Embedment 1

Design Resistance $f_{c,cyl} - 32\text{Mpa}$									
Rebar size			Ø10	Ø12	Ø16	Ø20	Ø24	Ø28	Ø32
Embedment depth	[mm]		60	72	96	120	144	168	192
Base material thickness	[mm]		100	104	136	170	210	238	272
Spacing dist $s=s_{min}$	[mm]		50	60	80	100	120	140	160
Tensile $N_{Rd}$									
	Pull-out	$N_{Rd,p}^*$ [kN]	9.1	17.6	30.5	46.5	68.0	88.1	115.1
	Concrete	$N_{Rd,c}^*$ [kN]	17.8	22.4	34.4	48.0	64.4	79.5	98.6
Shear $V_{Rd}$									
$V_{Rd,s}$ steel (per anchor)	[kN]		14.7	20.7	36.7	57.3	83.0	112.7	147.3
$V_{Rd,c}^*$ pryout	[kN]		18.3	35.2	61.0	93.0	135.2	168.9	206.4

### Embedment 2

Design Resistance $f_{c,cyl} - 32\text{Mpa}$									
Rebar size			Ø10	Ø12	Ø16	Ø20	Ø24	Ø28	Ø32
Embedment depth	[mm]		90	110	145	170	210	270	300
Base material thickness	[mm]		120	142	185	220	270	340	380
Spacing dist $s=s_{min}$	[mm]		50	60	80	100	125	140	160
Tensile $N_{Rd}$									
	Pull-out	$N_{Rd,p}^*$ [kN]	13.3	26.3	51.0	64.7	97.4	140.6	174.8
	Concrete	$N_{Rd,c}^*$ [kN]	29.2	39.2	65.9	76.0	104.6	150.1	178.2
Shear $V_{Rd}$									
$V_{Rd,s}$ steel (per anchor)	[kN]		14.7	20.7	36.7	57.3	83.0	112.7	147.3
$V_{Rd,c}^*$ pryout	[kN]		26.6	52.7	90.6	129.4	194.8	281.2	349.7

### Embedment 3

Design Resistance $f_{c,cyl} - 32\text{Mpa}$									
Rebar size			Ø10	Ø12	Ø16	Ø20	Ø24	Ø28	Ø32
Embedment depth	[mm]		120	144	192	240	288	336	384
Base material thickness	[mm]		150	176	232	290	348	406	464
Spacing dist $s=s_{min}$	[mm]		50	60	80	100	125	140	160
Tensile $N_{Rd}$									
	Pull-out	$N_{Rd,p}^*$ [kN]	17.9	35.0	61.2	94.2	138.1	179.2	230.8
	Concrete	$N_{Rd,c}^*$ [kN]	43.6	57.3	88.2	123.3	162.6	204.2	251.7
Shear $V_{Rd}$									
$V_{Rd,s}$ steel (per anchor)	[kN]		14.7	20.7	36.7	57.3	83.0	112.7	147.3

## Materials

### Mechanical properties of rebar BSt 500S

Anchor size			Ø8	Ø10	Ø12	Ø14	Ø16	Ø20	Ø24	Ø28	Ø32
Nominal tensile strength $f_{uk}$	BSt 500 S	[N/mm <sup>2</sup> ]	550	550	550	550	550	550	550	550	550
Yield strength $f_{yk}$	BSt 500 S	[N/mm <sup>2</sup> ]	500	500	500	500	500	500	500	500	500
Stressed cross-section $A_s$	BSt 500 S	[mm <sup>2</sup> ]	50.3	78.5	113.1	153.9	201.1	314.2	452	615.8	804.2
Moment of resistance	BSt 500 S	[mm <sup>3</sup> ]	50.3	98.2	169.6	269.4	402.1	785.4	1415	2155	3217

## Material quality

Part	Material
rebar BSt 500 S	Geometry and mechanical properties according to DIN 488-2:1986 or E DIN 488-2:2006

## Setting

### installation equipment

Anchor size	Ø8	Ø10	Ø12	Ø14	Ø16	Ø20	Ø24	Ø28	Ø32	
Rotary hammer	TE 2 - TE 30						TE 40- TE 70			
Other tools	compressed air gun or blow out pump, set of cleaning brushes, dispenser									

## Setting instructions

### Bore hole drilling

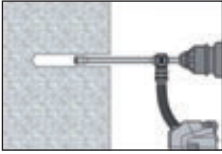

Drill hole to the required embedment depth with an appropriately sized Hilti TE-CD or TE-YD hollow drill bit with Hilti vacuum attachment. This drilling method properly cleans the borehole and removes dust while drilling. After drilling is complete, proceed to the “**injection preparation**” step in the instructions for use

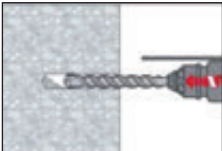

Drill Hole to the required embedment depth with a hammer drill set in rotation-hammer mode using an appropriately sized carbide drill bit.

### Bore hole cleaning Just before setting an anchor, the bore hole must be free of dust and debris.

#### a) Manual Cleaning (MC) non-cracked concrete only for bore hole diameters $d_0 \leq 20$ mm and bore hole depth $h_0 \leq 10d$

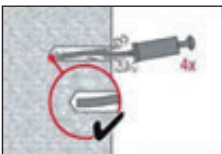

The Hilti manual pump may be used for blowing out bore holes up to diameters  $d_0 \leq 20$  mm and embedment depths up to  $h_{ef} \leq 10d$ . Blow out at least 4 times from the back of the bore hole until return air stream is free of noticeable dust

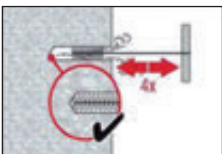

Brush 4 times with the specified brush size by inserting the steel brush Hilti HIT-RB to the back of the hole (if needed with extension) in a twisting motion and removing it. The brush must produce natural resistance as it enters the bore hole -- if not the brush is too small and must be replaced with the proper brush diameter.

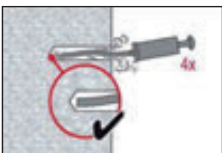

Blow out again with manual pump at least 4 times until return air stream is free of noticeable dust.

#### b) Compressed air cleaning (CAC) for all bore hole diameters $d_0$ and all bore hole depth $h_0$



Blow 2 times from the back of the hole (if needed with nozzle extension) over the hole length with oil-free compressed air (min. 6 bar at 6 m<sup>3</sup>/h) until return air stream is free of noticeable dust. Bore hole diameter  $\geq 32$  mm the compressor must supply a minimum air flow of 140 m<sup>3</sup>/hour.

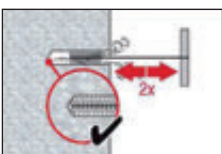

Brush 2 times with the specified brush size by inserting the steel brush Hilti HIT-RB to the back of the hole (if needed with extension) in a twisting motion and removing it. The brush must produce natural resistance as it enters the bore hole -- if not the brush is too small and must be replaced with the proper brush diameter.



Blow out again with manual pump at least 4 times until return air stream is free of noticeable dust.

## Setting instructions

### Injection preparation

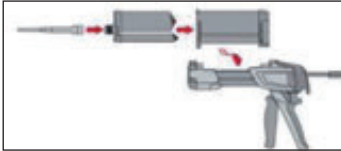

Tightly attach new Hilti mixing nozzle HIT-RE-M to foil pack manifold (snug fit). Do not modify the mixing nozzle. Observe the instruction for use of the dispenser. Check foil pack holder for proper function. Do not use damaged foil packs / holders. Swing foil pack holder with foil pack into HIT dispenser.

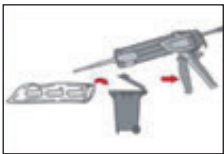

Discard initial adhesive. The foil pack opens automatically as dispensing is initiated. Depending on the size of the foil pack an initial amount of adhesive has to be discarded.

Discard quantities are:

2 strokes for 330 ml foil pack,

3 strokes for 500 ml foil pack,

4 strokes for 500 ml foil pack  $\leq 5^{\circ}\text{C}$ .

### Inject adhesive from the back of the borehole without forming air voids

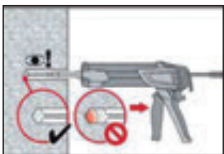

Inject the adhesive starting at the back of the hole, slowly withdrawing the mixer with each trigger pull. Fill holes approximately 2/3 full, or as required to ensure that the annular gap between the anchor and the concrete is completely filled with adhesive along the embedment length.



After injection is completed, depressurise the dispenser by pressing the release trigger. This will prevent further adhesive discharge from the mixer.

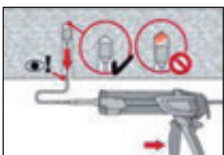

Overhead installation and/or installation with embedment depth  $h_{ef} > 250\text{mm}$ . For overhead installation the injection is only possible with the aid of extensions and piston plugs. Assemble HIT-RE-M mixer, extension(s) and appropriately sized piston plug. Insert piston plug to back of the hole and inject adhesive. During injection the piston plug will be naturally extruded out of the bore hole by the adhesive pressure.

### Setting the element

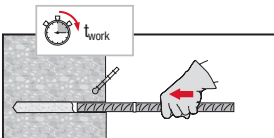

Before use, verify that the element is dry and free of oil and other contaminants.

Mark and set element to the required embedment depth until working time  $t_{\text{work}}$  has elapsed

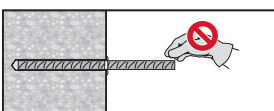

For overhead installation use piston plugs and fix embedded parts with e.g. wedges HIT-OHW

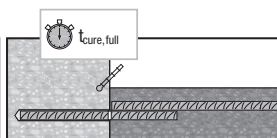
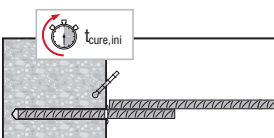

Loading the anchor:

After required curing time  $t_{\text{cure}}$  the anchor can be loaded.

## Working time, curing time

Temperature of the base material $T_{BM}$	Working time in which anchor can be inserted and adjusted $t_{work}$	Curing time before anchor can be loaded $t_{cure}$
-10 °C to -5 °C	3 hour	20 hour
-4 °C to 0 °C	2 hour	7 hour
1 °C to 5 °C	1 hour	3 hour
6 °C to 10 °C	40 min	2 hour
11 °C to 20 °C	15 min	1 hour
21 °C to 30 °C	9 min	1 hour
31 °C to 40 °C	6 min	1 hour

## Setting details

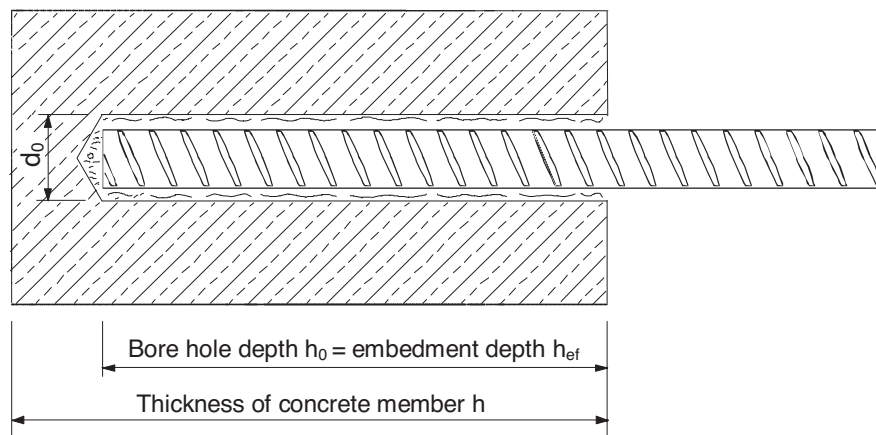





		Data according ETA-11/0493 and ETA-12/0084, issue 2013-06-20								
Anchor size		Ø8	Ø10	Ø12	Ø14	Ø16	Ø20	Ø24	Ø28	Ø32
Nominal diameter of drill bit	$d_0$ [mm]	12 (10) <sup>a)</sup>	14 (12) <sup>a)</sup>	16 (14) <sup>a)</sup>	18	20	25	32	35	40
Effective anchorage and drill hole depth range	$h_{ef,min}$ [mm]	60	60	70	75	80	90	100	112	128
	$h_{ef,max}$	160	200	240	280	320	400	500	560	640
Minimum base material thickness	$h_{min}$ [mm]	$h_{ef} + 30$ mm			$h_{ef} + 2 d_0$					
Minimum spacing	$s_{min}$ [mm]	40	50	60	70	80	100	125	140	160
Minimum edge distance	$c_{min}$ [mm]	40	50	60	70	80	100	125	140	160

a) both given values for drill bit diameter can be used

b)  $h_{ef,min}$   $h_{ef}$   $h_{ef,max}$  ( $h_{ef}$ : embedment depth)

c)  $h$ : base material thickness ( $h \geq h_{min}$ )

## Hilti HIT-RE 500 with HIT-V / HAS in hammer drilled holes

Injection Mortar System	Benefits
 <p>Hilti HIT-RE 500 330 ml foil pack (also available as 500 ml and 1400 ml foil pack)</p>	<ul style="list-style-type: none"> <li>■ suitable for non-cracked concrete C 20/25 to C 50/60</li> <li>■ high loading capacity</li> <li>■ suitable for dry and water saturated concrete</li> <li>■ under water application</li> <li>■ large diameter applications</li> <li>■ high corrosion resistant</li> <li>■ long working time at elevated temperatures</li> <li>■ odourless epoxy</li> <li>■ embedment depth range: from 40 ... 160 mm for M8 to 120 ... 600 mm for M30</li> </ul>
 <p>Static mixer</p>	
 <p>HAS-E rod</p>	
 <p>HIT-V rods HIT-V (Zinc) HIT-V-F (Gal) HIT-V-R (A4-70) HIT-V-HCR rods</p>	



Concrete



Small edge  
distance  
& spacing



Variable  
embedment  
depth



Fire  
resistance



Corrosion  
resistance



High  
corrosion  
resistance



European  
Technical  
Approval



CE  
conformity



PROFIS  
anchor design  
software



SAFEset  
approved  
automatic  
cleaning

### Approvals / certificates

Description	Authority / Laboratory	No. / date of issue
European technical approval a)	DIBt, Berlin	ETA-04/0027 / 2013-06-26
Fire test report	IBMB, Braunschweig	UB 3565 / 4595 / 2006-10-29 UB 3588 / 4825 / 2005-11-15
Assessment report (fire)	warringtonfire	WF 166402 / 2007-10-26 & suppl. WF 172920 / 2008-05-27

a) All data given in this section according ETA-04/0027, issue 2013-06-26.

### Service temperature range

Hilti HIT-RE 500 injection mortar may be applied in the temperature ranges given below. An elevated base material temperature may lead to a reduction of the design bond resistance.

Temperature range	Base material temperature	Maximum long term base material temperature	Maximum short term base material temperature
Temperature range I	-40 °C to +40 °C	+24 °C	+40 °C
Temperature range II	-40 °C to +58 °C	+35 °C	+58 °C
Temperature range III	-40 °C to +70 °C	+43 °C	+70 °C

#### Max short term base material temperature

Short-term elevated base material temperatures are those that occur over brief intervals, e.g. as a result of diurnal cycling.

#### Max long term base material temperature

Long-term elevated base material temperatures are roughly constant over significant periods of time



## Design process for typical anchor layouts

The design values in the tables are obtained from Profis V2.4.2 in compliance with the design method according to EOTA TR 029. Design resistance according to data given in ETA-04/0027, issue 2013-06-26.

- Influence of concrete strength
- Influence of edge distance
- Influence of spacing

The design method is based on the following simplification:

- No different loads are acting on individual anchors (no eccentricity)

The values are valid for the anchor configuration.

For more complex fastening applications please use the anchor design software PROFIS Anchor.

### STEP 1: TENSION LOADING

The design tensile resistance  $N_{Rd}$  is the lower of:

- Combined pull-out and concrete cone resistance

$$N_{Rd,p} = f_{B,p} \cdot N^*_{Rd,p}^1$$

$N^*_{Rd,p}$  is obtained from the relevant design tables

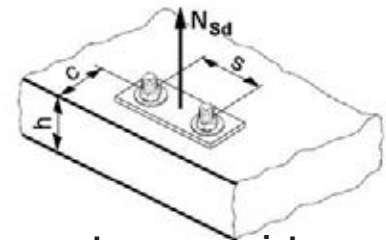

$f_{B,p}$  influence of concrete strength on combined pull-out and concrete cone resistance

Concrete Strengths $f'_{c,cyl}$ (MPa)	20	25	32	40	50
$f_{B,p}$	0.95	0.97	1.00	1.02	1.04

1 Data apply for dry concrete and hammer drilled holes only. For non-dry concrete multiply  $N_{Rd,p}$  by the factor 0.83  
For diamond cored holes please see chapter "HIT-RE 500 with HIT-V / HAS rods in diamond cored holes"

- Concrete cone or concrete splitting resistance

$$N_{Rd,c} = f_B \cdot N^*_{Rd,c}^2$$

$N^*_{Rd,c}$  is obtained from the relevant design tables

$f_B$  influence of concrete strength on concrete cone resistance

Concrete Strengths $f'_{c,cyl}$ (MPa)	20	25	32	40	50
$f_B$	0.79	0.87	1.00	1.11	1.22

2 For non dry concrete multiply  $N_{Rd,c}$  by the factor 0.83.

The definition of Dry Concrete, as per Hilti is: concrete not in contact with water before/during installation and curing.

- Design steel resistance (tension)  $N_{Rd,s}$

Anchor size			M8	M10	M12	M16	M20	M24	M30
$N_{Rd,s}$	HAS - E 5.8	[kN]	11.3	17.3	25.3	48.0	74.7	106.7	-
	HIT-V 5.8	[kN]	12.0	19.3	28.0	52.7	82.0	118.0	187.3
	HIT-V 8.8	[kN]	19.3	30.7	44.7	84.0	130.7	188.0	299.3
	HAS-E-R	[kN]	12.3	19.8	28.3	54.0	84.0	119.8	92.0
	HIT-V-R	[kN]	13.9	21.9	31.6	58.8	92.0	132.1	98.3

$$N_{Rd} = \min \{ N_{Rd,p}, N_{Rd,c}, N_{Rd,s} \}$$

**CHECK  $N_{Rd} \geq N_{Sd}$**

## STEP 2: SHEAR LOADING

The design shear resistance  $V_{Rd}$  is the lower of:

### ■ Design Concrete Edge Resistance

$$V_{Rd,c} = f_B \cdot V^*_{Rd,c}$$

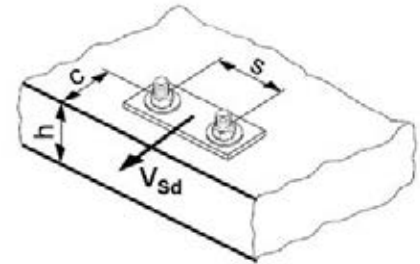

$V^*_{Rd,c}$  is obtained from the relevant design table

### $f_B$ influence of concrete strength

Concrete Strengths $f'_{c,cyl}$ (MPa)	20	25	32	40	50
$f_B$	0.79	0.87	1.00	1.11	1.22

### Shear load acting parallel to edge:

These tables are for a single free edge only

#### 2 anchors:

For shear loads acting parallel to this edge, the concrete resistance  $V^*_{Rd,c}$  can be multiplied by the factor = 2.5

#### 4 anchors:

For shear loads acting parallel to the edge - the anchor row closest to the edge is checked to resist half the total design load.

To obtain the concrete resistance use the corresponding 2 anchor configuration  $V^*_{Rd,c}$  and multiply by the factor = 2.5

### ■ Design steel resistance (shear): $V_{Rd,s}$

Anchor size		M8	M10	M12	M16	M20	M24	M30	
$V_{Rd,s}$	HAS - E 5.8	[kN]	6.8	10.4	15.2	28.8	44.8	64.0	-
	HIT-V 5.8	[kN]	7.2	12.0	16.8	31.2	48.8	70.4	112.0
	HIT-V 8.8	[kN]	12.0	18.4	27.2	50.4	78.4	112.8	179.2
	HAS-E-R	[kN]	7.7	12,2	17.3	32.7	50.6	71.8	55.5
	HIT-V-R	[kN]	8.3	12.8	19.2	35.3	55.1	79.5	58.8

$$V_{Rd} = \min \{ V_{Rd,c}, V_{Rd,s} \}$$

**CHECK  $V_{Rd} \geq V_{Sd}$**

## STEP 3: COMBINED TENSION AND SHEAR LOADING

The following equations must be satisfied:

$$N_{Sd}/N_{Rd} + V_{Sd}/V_{Rd} \leq 1.2$$

and

$$N_{Sd}/N_{Rd} \leq 1, V_{Sd}/V_{Rd} \leq 1$$

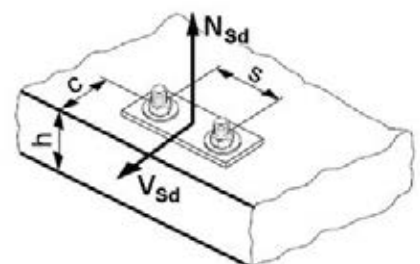

## Precalculated table values – design resistance values

### General:

The following tables provide the total ultimate limit state design resistance for the configurations. All tables are based upon:

- correct setting (See setting instruction)
- non-cracked concrete –  $f_{c,cyl} = 32$  MPa
- temperature range I (see service temperature range)
- base material thickness, as specified in the table
- One typical embedment depth, as specified in the tables
- dry concrete, hammer drilled hole
- for non-dry concrete multiply values by the factor 0.83
- for diamond cored holes please see chapter “HIT-RE 500 with HIT-V / HAS rods in diamond cored holes”

The following tables give design values for typical embedment depths. The latest version of the Hilti software Profis allows the engineer to optimise their design by varying the embedment depth according to the applied loads to achieve an economical solution every time. This is done by selecting HIT-V-Rods.

For more information on the HIT V rods please refer to the Chemical Anchor Components & Accessories section on page 240.

The anchor design software program Profis can be download from the Hilti Australia website, [www.hilti.com.au](http://www.hilti.com.au).

## Basic loading data (for a single anchor) – no edge distance and spacing influence

### Embedment depth and base material thickness for the basic loading data

Anchor size	M8	M10	M12	M16	M20	M24	M30
Typical embedment depth $h_{ef}$ [mm]	80	90	110	125	170	210	270
Base material thickness $h$ [mm]	110	120	150	200	250	300	350



### Design resistance [kN] - dry concrete, 32 Mpa

Anchor size		M8	M10	M12	M16	M20	M24	M30
Non-cracked concrete								
Tensile	Pull-out $N_{Rd,p}^*$	19.2	27.0	39.7	56.4	95.8	132.7	198.1
	Concrete $N_{Rd,c}^*$	26.1	31.0	42.0	51.0	80.9	111.1	161.9
Shear	$V_{Rd,s}$	Steel governed refer $V_{Rd,s}$ table						

**Note:** for cracked concrete refer HIT-RE 500-SD section page XX.

## Basic loading data (for a single anchor) – with minimum edge distance

### Design resistance [kN] - dry concrete, 32 Mpa

Anchor size		M8	M10	M12	M16	M20	M24
Min. edge distance $c_{min}$ [mm]		40	50	60	80	100	120
Min Base thickness $h_{min}$ [mm]		110	120	150	200	250	300
<b>Tensile <math>N_{Rd}</math></b>							
	Pull-out $N_{Rd,p}^*$	10.4	15.0	22.0	33.2	54.6	74.6
	Concrete $N_{Rd,c}^*$	12.5	15.1	21.5	30.1	45.6	60.5
<b>Shear <math>V_{Rd}</math></b>							
	Shear $V_{Rd,c}$ (without lever arm)	4.7	6.8	9.3	14.5	21.7	29.8

## Two Anchors

**Table 1:** One edge influence

Design Data:  $f_{c,cyl}=32$  MPa

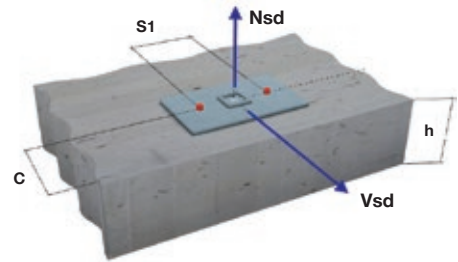

Anchor size	M8	M10	M12	M16	M20	M24
Typical embedment depth $h_{ef}$ [mm]	80	90	110	125	170	210
Base material thickness $h$ [mm]	110	120	150	200	250	300

ANCHOR <b>M8</b>	Edge C (mm)														
	40			80			100			150			170		
	tension		shear	tension		shear	tension		shear	tension		shear	tension		shear
spacing $s_1$ (mm)	$N^*_{Rd,p}$	$N^*_{Rd,c}$	$V^*_{Rd,c}$	$N^*_{Rd,p}$	$N^*_{Rd,c}$	$V^*_{Rd,c}$	$N^*_{Rd,p}$	$N^*_{Rd,c}$	$V^*_{Rd,c}$	$N^*_{Rd,p}$	$N^*_{Rd,c}$	$V^*_{Rd,c}$	$N^*_{Rd,p}$	$N^*_{Rd,c}$	$V^*_{Rd,c}$
40	13.2	13.9	6.3	18.7	18.1	13.2	21.8	20.3	15.4	24.5	26.5	21.0	24.6	29.2	23.2
80	14.8	15.4	7.9	21.0	19.9	15.0	24.4	22.4	17.2	27.5	29.3	22.7	27.5	32.3	24.9
100	15.6	16.1	8.6	22.1	20.9	15.9	25.7	23.5	18.1	28.6	30.7	23.6	28.9	33.8	25.7
120	16.3	16.8	9.4	23.2	21.8	16.9	27.0	24.6	19.0	30.4	32.0	24.5	30.4	35.3	26.6
150	17.5	17.9	9.4	24.8	23.3	18.3	28.9	26.2	20.4	32.5	34.2	25.7	32.5	37.7	27.9
200	19.4	19.8	9.4	27.6	25.7	20.6	32.0	28.9	22.6	36.1	37.7	27.9	36.1	41.5	30.0

ANCHOR <b>M10</b>	Edge C (mm)														
	50			80			100			150			200		
	tension		shear	tension		shear	tension		shear	tension		shear	tension		shear
spacing $s_1$ (mm)	$N^*_{Rd,p}$	$N^*_{Rd,c}$	$V^*_{Rd,c}$	$N^*_{Rd,p}$	$N^*_{Rd,c}$	$V^*_{Rd,c}$	$N^*_{Rd,p}$	$N^*_{Rd,c}$	$V^*_{Rd,c}$	$N^*_{Rd,p}$	$N^*_{Rd,c}$	$V^*_{Rd,c}$	$N^*_{Rd,p}$	$N^*_{Rd,c}$	$V^*_{Rd,c}$
50	18.6	17.0	9.0	23.4	20.3	15.0	26.9	22.4	17.4	33.5	28.6	23.4	33.5	35.2	29.3
100	21.2	19.0	11.3	26.8	22.6	17.6	30.7	25.1	19.9	38.3	31.8	25.7	38.3	39.0	31.5
150	23.9	20.9	13.5	30.0	24.7	20.2	34.4	27.5	22.4	43.0	35.0	28.1	43.0	43.0	33.8
200	26.5	22.8	13.5	33.4	27.0	22.8	38.3	30.1	24.9	47.6	38.3	30.4	47.6	46.9	36.1
250	29.0	24.7	13.5	36.6	29.3	24.8	42.0	32.5	27.4	52.3	41.4	32.7	52.3	50.8	38.3
300	30.1	26.6	13.5	37.9	31.6	24.8	43.4	35.2	29.9	54.2	44.6	35.1	54.2	54.7	40.6

ANCHOR <b>M12</b>	Edge C (mm)														
	60			80			100			150			200		
	tension		shear	tension		shear	tension		shear	tension		shear	tension		shear
spacing $s_1$ (mm)	$N^*_{Rd,p}$	$N^*_{Rd,c}$	$V^*_{Rd,c}$	$N^*_{Rd,p}$	$N^*_{Rd,c}$	$V^*_{Rd,c}$	$N^*_{Rd,p}$	$N^*_{Rd,c}$	$V^*_{Rd,c}$	$N^*_{Rd,p}$	$N^*_{Rd,c}$	$V^*_{Rd,c}$	$N^*_{Rd,p}$	$N^*_{Rd,c}$	$V^*_{Rd,c}$
60	26.4	24.2	12.3	30.0	26.6	16.7	33.8	29.3	21.4	44.4	36.2	28.2	47.9	43.8	35.0
100	28.9	26.0	14.4	33.0	28.7	18.9	37.2	31.4	23.8	48.7	38.9	30.5	52.6	47.2	37.1
150	32.2	28.3	16.9	36.6	31.2	21.7	41.4	34.2	26.7	54.2	42.4	33.2	58.4	51.2	39.7
200	35.4	30.6	18.5	40.3	33.7	24.5	45.5	37.0	29.7	59.6	45.7	36.0	64.2	55.3	42.4
250	38.6	32.9	18.5	44.0	36.2	26.7	49.7	39.7	32.7	65.2	49.1	38.7	70.1	59.4	45.0
300	41.9	35.2	18.5	47.6	38.8	26.7	53.8	42.5	35.7	70.6	52.6	41.5	76.0	63.6	47.7

ANCHOR <b>M16</b>	Edge C (mm)														
	80			100			150			200			250		
	tension		shear	tension		shear	tension		shear	tension		shear	tension		shear
spacing s1 (mm)	N <sup>*Rd,p</sup>	N <sup>*Rd,c</sup>	V <sup>*Rrd,c</sup>	N <sup>*Rd,p</sup>	N <sup>*Rd,c</sup>	V <sup>*Rrd,c</sup>	N <sup>*Rd,p</sup>	N <sup>*Rd,c</sup>	V <sup>*Rrd,c</sup>	N <sup>*Rd,p</sup>	N <sup>*Rd,c</sup>	V <sup>*Rrd,c</sup>	N <sup>*Rd,p</sup>	N <sup>*Rd,c</sup>	V <sup>*Rrd,c</sup>
80	40.4	36.6	19.3	45.1	40.8	24.4	58.0	52.3	36.2	68.5	61.9	44.1	68.5	61.9	52.0
100	42.2	38.2	20.5	47.2	42.6	25.7	60.5	54.7	37.5	71.5	64.6	45.4	71.5	64.6	53.2
150	46.7	42.2	23.6	52.1	47.0	28.9	66.8	60.5	41.0	79.1	71.4	48.6	79.1	71.4	56.3
200	51.1	46.2	26.6	57.1	51.6	32.1	73.2	66.1	44.4	86.5	78.2	51.9	86.5	78.2	59.4
250	55.6	50.3	29.0	62.0	56.0	35.3	79.6	71.9	47.8	94.1	85.1	55.1	94.1	85.1	62.6
300	60.0	54.2	29.0	67.0	60.6	38.6	85.9	77.3	51.2	101.6	91.8	58.4	101.6	91.8	65.7

ANCHOR <b>M20</b>	Edge C (mm)														
	120			150			200			250			300		
	tension		shear	tension		shear	tension		shear	tension		shear	tension		shear
spacing s1 (mm)	N <sup>*Rd,p</sup>	N <sup>*Rd,c</sup>	V <sup>*Rrd,c</sup>	N <sup>*Rd,p</sup>	N <sup>*Rd,c</sup>	V <sup>*Rrd,c</sup>	N <sup>*Rd,p</sup>	N <sup>*Rd,c</sup>	V <sup>*Rrd,c</sup>	N <sup>*Rd,p</sup>	N <sup>*Rd,c</sup>	V <sup>*Rrd,c</sup>	N <sup>*Rd,p</sup>	N <sup>*Rd,c</sup>	V <sup>*Rrd,c</sup>
100	65.3	52.4	28.9	79.8	61.9	44.0	95.8	72.0	55.5	113.0	82.8	64.6	114.7	94.3	73.5
150	70.7	55.9	32.5	86.4	65.9	48.0	103.6	76.7	59.5	122.3	88.2	68.4	124.2	100.4	77.2
200	76.1	59.3	36.1	93.0	70.0	52.0	111.5	81.4	63.5	131.5	93.6	72.2	133.6	106.1	80.9
250	81.4	62.8	39.7	99.5	74.0	56.0	119.3	86.2	67.4	140.8	99.0	76.0	143.0	112.8	84.6
300	86.8	66.1	43.4	106.1	78.0	60.0	127.2	90.8	71.4	150.0	104.4	79.8	152.4	118.9	88.2
350	92.0	69.6	43.4	112.7	82.1	64.0	135.0	95.5	75.4	159.2	109.8	83.6	161.8	125.2	92.0

ANCHOR <b>M24</b>	Edge C (mm)														
	120			150			200			250			350		
	tension		shear	tension		shear	tension		shear	tension		shear	tension		shear
spacing s1 (mm)	N <sup>*Rd,p</sup>	N <sup>*Rd,c</sup>	V <sup>*Rrd,c</sup>	N <sup>*Rd,p</sup>	N <sup>*Rd,c</sup>	V <sup>*Rrd,c</sup>	N <sup>*Rd,p</sup>	N <sup>*Rd,c</sup>	V <sup>*Rrd,c</sup>	N <sup>*Rd,p</sup>	N <sup>*Rd,c</sup>	V <sup>*Rrd,c</sup>	N <sup>*Rd,p</sup>	N <sup>*Rd,c</sup>	V <sup>*Rrd,c</sup>
120	88.9	69.0	39.7	98.3	74.8	49.7	115.1	84.8	67.5	133.0	95.4	77.6	158.0	118.3	97.6
150	92.4	71.2	42.3	102.2	77.0	52.3	119.6	87.5	70.3	138.2	98.4	80.2	164.4	122.0	100.1
200	98.4	74.8	46.4	108.8	81.0	56.6	127.3	91.8	75.0	147.1	103.3	84.7	174.8	128.2	104.2
250	104.3	78.2	50.5	115.3	84.8	61.0	135.0	96.1	79.6	156.0	108.2	89.2	185.4	134.2	108.4
300	110.2	81.8	54.7	121.9	88.7	65.3	142.7	100.6	84.3	164.9	113.2	93.6	196.0	140.2	112.6
350	116.2	85.3	58.8	128.5	92.5	69.7	150.4	104.9	89.0	173.8	118.1	98.1	206.5	146.4	116.8

## Four anchors

**Table 2:** One edge influence

Design Data:  $f_{c,cyl}=32$  MPa

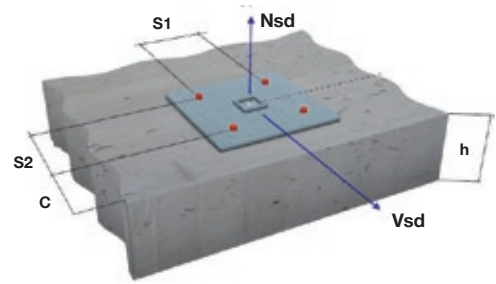

Anchor size	M8	M10	M12	M16	M20	M24
Typical embedment depth $h_{ef}$ [mm]	80	90	110	125	170	210
Base material thickness $h$ [mm]	110	120	150	200	250	300

ANCHOR <b>M8</b>	Edge C (mm)														
	40			80			100			150			200		
	tension		shear	tension		shear	tension		shear	tension		shear	tension		shear
spacing $s1=s2$ (mm)	$N^*_{Rd,p}$	$N^*_{Rd,c}$	$V^*_{Rd,c}$	$N^*_{Rd,p}$	$N^*_{Rd,c}$	$V^*_{Rd,c}$	$N^*_{Rd,p}$	$N^*_{Rd,c}$	$V^*_{Rd,c}$	$N^*_{Rd,p}$	$N^*_{Rd,c}$	$V^*_{Rd,c}$	$N^*_{Rd,p}$	$N^*_{Rd,c}$	$V^*_{Rd,c}$
40	18.5	16.6	12.6	25.1	21.0	17.7	28.8	23.3	19.9	32.0	29.8	25.4	32.0	32.6	30.9
80	24.1	21.2	15.8	31.9	26.4	23.8	36.1	29.2	26.0	40.0	36.6	31.5	40.0	39.8	36.8
100	27.4	23.8	17.2	35.6	29.3	26.8	40.1	32.3	29.0	44.2	40.3	34.4	44.2	43.8	39.7
120	30.6	26.4	18.8	39.5	32.4	29.8	44.3	35.5	32.0	48.7	44.2	37.3	48.7	47.8	42.6
150	35.8	30.7	18.8	45.6	37.2	34.3	50.9	40.8	36.4	55.7	50.2	41.7	55.7	54.2	47.0
200	45.0	38.5	18.8	56.5	46.2	41.2	62.6	50.3	43.7	68.2	61.2	49.0	68.2	65.9	54.2

ANCHOR <b>M10</b>	Edge C (mm)														
	50			80			100			150			200		
	tension		shear	tension		shear	tension		shear	tension		shear	tension		shear
spacing $s1=s2$ (mm)	$N^*_{Rd,p}$	$N^*_{Rd,c}$	$V^*_{Rd,c}$	$N^*_{Rd,p}$	$N^*_{Rd,c}$	$V^*_{Rd,c}$	$N^*_{Rd,p}$	$N^*_{Rd,c}$	$V^*_{Rd,c}$	$N^*_{Rd,p}$	$N^*_{Rd,c}$	$V^*_{Rd,c}$	$N^*_{Rd,p}$	$N^*_{Rd,c}$	$V^*_{Rd,c}$
50	25.1	20.5	17.4	30.6	23.9	21.0	34.6	26.3	23.4	42.0	32.8	29.3	42.0	39.5	35.1
100	34.1	26.6	22.6	40.8	30.6	29.2	45.6	33.4	31.5	54.6	40.9	37.2	54.6	48.8	43.0
150	44.4	33.5	27.0	52.3	38.2	37.2	58.0	41.4	39.4	68.6	50.2	45.1	68.6	59.3	50.7
200	55.9	41.2	27.0	65.2	46.4	45.0	71.9	50.3	47.2	84.2	60.2	52.8	84.2	70.6	58.4
250	68.6	49.6	27.0	79.4	55.7	49.6	87.0	59.3	54.8	101.2	71.2	60.5	101.4	82.9	66.0
300	74.0	58.8	27.0	85.4	65.6	49.6	93.5	70.4	59.8	108.4	83.2	68.0	108.4	96.2	73.5

ANCHOR <b>M12</b>	Edge C (mm)														
	60			80			100			150			200		
	tension		shear	tension		shear	tension		shear	tension		shear	tension		shear
spacing $s1=s2$ (mm)	$N^*_{Rd,p}$	$N^*_{Rd,c}$	$V^*_{Rd,c}$	$N^*_{Rd,p}$	$N^*_{Rd,c}$	$V^*_{Rd,c}$	$N^*_{Rd,p}$	$N^*_{Rd,c}$	$V^*_{Rd,c}$	$N^*_{Rd,p}$	$N^*_{Rd,c}$	$V^*_{Rd,c}$	$N^*_{Rd,p}$	$N^*_{Rd,c}$	$V^*_{Rd,c}$
60	34.3	29.0	24.1	38.3	31.8	26.9	42.6	34.4	29.6	54.2	41.9	36.3	58.0	49.8	42.9
100	42.7	34.8	28.8	47.3	37.8	34.4	52.2	40.8	37.1	65.5	49.0	43.6	69.8	58.0	50.1
150	54.5	42.6	33.8	60.0	46.0	43.4	65.8	49.4	46.2	81.2	58.8	52.7	86.2	68.9	59.1
200	67.7	51.2	37.0	74.0	55.1	49.0	80.6	58.9	55.2	98.5	69.5	61.5	104.2	80.8	67.9
250	82.2	60.6	37.0	89.4	64.8	53.4	97.1	69.2	64.0	117.5	81.0	70.3	124.0	93.6	76.6
300	98.0	70.7	37.0	106.3	75.5	53.4	115.0	80.4	71.4	138.0	93.4	79.0	145.3	107.3	85.2

**Shear design:** The concrete edge resistance value in this table uses all 4 anchors in shear. You will need to ensure the gap between anchor and the plate is filled. This can be achieved using the Hilti Dynamic Set. (Refer page 41 for further details)

The concrete edge resistance values have been obtained by taking the lesser of:

1. First row resistance multiplied by number of rows and
2. The concrete edge resistance of the furthest row.

ANCHOR <b>M16</b>	Edge C (mm)														
	80			100			150			200			250		
	tension		shear	tension		shear	tension		shear	tension		shear	tension		shear
spacing s1=s2 (mm)	N*Rd,p	N*Rd,c	V*Rrd,c	N*Rd,p	N*Rd,c	V*Rrd,c	N*Rd,p	N*Rd,c	V*Rrd,c	N*Rd,p	N*Rd,c	V*Rrd,c	N*Rd,p	N*Rd,c	V*Rrd,c
80	52.6	47.5	37.8	57.7	52.1	40.9	71.6	64.8	48.8	83.2	75.1	56.6	83.2	75.1	64.3
100	58.0	52.4	41.0	63.5	57.5	45.4	78.4	70.9	53.2	90.6	81.8	60.9	90.6	81.8	68.6
150	72.8	65.9	47.2	79.3	71.6	56.3	96.6	86.6	64.0	110.6	100.0	71.5	110.6	100.0	79.1
200	89.4	80.6	53.2	96.7	86.9	64.1	116.6	103.2	74.5	132.7	120.0	82.0	132.7	120.0	89.5
250	107.5	95.9	58.0	115.9	102.8	70.6	138.6	121.2	85.0	156.8	141.1	92.4	156.8	141.7	99.7
300	127.3	112.4	58.0	136.9	120.1	77.2	162.4	140.6	95.2	182.9	163.0	102.6	182.9	165.2	110.0

ANCHOR <b>M20</b>	Edge C (mm)														
	100			150			200			250			300		
	tension		shear	tension		shear	tension		shear	tension		shear	tension		shear
spacing s1=s2 (mm)	N*Rd,p	N*Rd,c	V*Rrd,c	N*Rd,p	N*Rd,c	V*Rrd,c	N*Rd,p	N*Rd,c	V*Rrd,c	N*Rd,p	N*Rd,c	V*Rrd,c	N*Rd,p	N*Rd,c	V*Rrd,c
100	83.8	64.6	55.5	99.6	74.6	64.6	116.9	85.4	73.5	135.4	97.0	82.4	137.3	109.2	91.2
150	100.4	75.2	65.0	118.4	86.4	77.2	137.8	98.3	86.0	158.5	110.9	94.7	160.7	124.3	103.4
200	118.9	86.8	72.2	139.0	99.0	89.6	160.4	112.0	98.2	183.6	125.8	106.8	186.0	140.4	115.4
250	138.7	99.0	79.4	160.9	112.4	101.7	184.9	126.6	110.3	210.5	141.6	118.8	213.1	157.4	127.3
300	160.0	112.1	86.8	184.7	126.6	113.7	211.0	142.0	122.2	239.2	158.3	130.7	242.0	175.4	139.1
350	182.9	126.0	86.8	210.0	141.7	125.6	238.9	158.4	134.0	269.6	175.9	142.4	272.9	194.4	150.8

ANCHOR <b>M24</b>	Edge C (mm)														
	120			150			200			250			350		
	tension		shear	tension		shear	tension		shear	tension		shear	tension		shear
spacing s1=s2 (mm)	N*Rd,p	N*Rd,c	V*Rrd,c	N*Rd,p	N*Rd,c	V*Rrd,c	N*Rd,p	N*Rd,c	V*Rrd,c	N*Rd,p	N*Rd,c	V*Rrd,c	N*Rd,p	N*Rd,c	V*Rrd,c
120	113.4	84.2	75.5	123.7	90.4	81.6	141.8	101.0	91.6	161.2	111.7	101.5	188.2	136.7	121.2
150	124.3	90.7	84.2	135.2	97.2	90.2	154.6	108.4	100.1	175.0	120.2	109.9	203.5	145.6	129.4
200	143.5	102.1	92.8	155.6	109.1	104.2	176.8	121.2	114.0	199.2	133.8	123.7	230.4	161.0	142.9
250	164.2	114.1	101.0	177.4	121.6	118.0	200.5	134.6	127.7	225.0	148.2	137.2	259.1	177.4	156.3
300	186.2	126.7	109.4	200.6	134.8	130.6	225.7	148.7	141.1	252.5	163.3	150.6	289.3	194.5	169.5
350	208.9	140.0	117.6	225.2	148.7	139.4	252.5	163.6	154.5	281.4	179.2	163.9	321.2	212.4	182.6

## Materials

### Mechanical properties of HIT-V / HAS

Anchor size			Data according ETA-04/0027, issue 2013-06-26							Additional Hilti technical data
			M8	M10	M12	M16	M20	M24	M30	M36
Nominal tensile strength $f_{uk}$	HIT-V/HAS 5.8 [N/mm <sup>2</sup> ]		500	500	500	500	500	500	500	500
	HIT-V/HAS 8.8 [N/mm <sup>2</sup> ]		800	800	800	800	800	800	800	800
	HIT-V/HAS -R [N/mm <sup>2</sup> ]		700	700	700	700	700	700	500	500
	HIT-V/HAS -HCR [N/mm <sup>2</sup> ]		800	800	800	800	800	700	700	500
Yield strength $f_{yk}$	HIT-V/HAS 5.8 [N/mm <sup>2</sup> ]		400	400	400	400	400	400	400	400
	HIT-V/HAS 8.8 [N/mm <sup>2</sup> ]		640	640	640	640	640	640	640	640
	HIT-V/HAS -R [N/mm <sup>2</sup> ]		450	450	450	450	450	450	210	210
	HIT-V/HAS -HCR [N/mm <sup>2</sup> ]		600	600	600	600	600	400	400	250
Stressed cross-section $A_s$	HAS [mm <sup>2</sup> ]		32.8	52.3	76.2	144	225	324	519	759
	HIT-V [mm <sup>2</sup> ]		36.6	58.0	84.3	157	245	353	561	817
Section Modulus $Z$	HAS [mm <sup>3</sup> ]		27.0	54.1	93.8	244	474	809	1706	2949
	HIT-V [mm <sup>3</sup> ]		31.2	62.3	109	277	541	935	1874	3294
<b>Steel failure with lever arm</b>			<b>M8</b>	<b>M10</b>	<b>M12</b>	<b>M16</b>	<b>M20</b>	<b>M24</b>	<b>M30</b>	<b>M36</b>
Design bending moment $M_{Rd,s}$	HIT-V-5.8 [Nm]		15	30	53	134	260	449	900	1581
	HIT-V-8.8 [Nm]		24	48	84	213	415	718	1439	2530
	HIT-V-R [Nm]		17	33	59	149	291	504	472	830
	HIT-V-HCR [Nm]		24	48	84	213	416	449	899	1129
	HAS-E-5.8 [Nm]		13	26	45	118	227	389	NA	NA
	HAS-E-8.8 [Nm]		NA	NA	NA	NA	NA	NA	1310	2265
	HAS-E-R [Nm]		15	29	51	131	255	436	430	743
	HAS-E-HCR [Nm]		21	42	72	187	364	389	819	1011



## Material quality

Part	Material
Threaded rod HIT-V(F), HAS 5.8 M8 – M24	Strength class 5.8, EN ISO 898-1, A5 > 8% ductile steel galvanized $\geq 5 \mu\text{m}$ , EN ISO 4042 (F) hot dipped galvanized $\geq 45 \mu\text{m}$ , EN ISO 10684
Threaded rod HIT-V(F), HAS 8.8 M27 – M39	Strength class 8.8, EN ISO 898-1, A5 > 8% ductile steel galvanized $\geq 5 \mu\text{m}$ , EN ISO 4042 (F) hot dipped galvanized $\geq 45 \mu\text{m}$ , EN ISO 10684
Threaded rod HIT-V-R, HAS-R	Stainless steel grade A4, A5 > 8% ductile strength class 70 for $\leq M24$ and class 50 for M27 to M30, EN ISO 3506-1, EN 10088: 1.4401
Threaded rod HIT-V-HCR, HAS-HCR	High corrosion resistant steel, EN ISO 3506-1, EN 10088: 1.4529; 1.4565 strength $\leq M20$ : $R_m = 800 \text{ N/mm}^2$ , $R_p 0.2 = 640 \text{ N/mm}^2$ , A5 > 8% ductile M24 to M30: $R_m = 700 \text{ N/mm}^2$ , $R_p 0.2 = 400 \text{ N/mm}^2$ , A5 > 8% ductile
Washer ISO 7089	Steel galvanized, EN ISO 4042; hot dipped galvanized, EN ISO 10684
	Stainless steel, EN 10088: 1.4401
	High corrosion resistant steel, EN 10088: 1.4529; 1.4565
Nut EN ISO 4032	Strength class 8, ISO 898-2 steel galvanized $\geq 5 \mu\text{m}$ , EN ISO 4042 hot dipped galvanized $\geq 45 \mu\text{m}$ , EN ISO 10684
	Strength class 70, EN ISO 3506-2, stainless steel grade A4, EN 10088: 1.4401
	Strength class 70, EN ISO 3506-2, high corrosion resistant steel, EN 10088: 1.4529; 1.4565

## Anchor dimensions

Anchor size	M8	M10	M12	M16	M20	M24	M30 <sup>a)</sup>	M36 <sup>a)</sup>
Anchor rod HAS, HAS-E, HAS-R, HAS-ER HAS-HCR	M8x80	M10x90	M12x110	M16x125	M20x170	M24x210	M30x270	M36x330
Anchor embedment depth [mm]	80	90	110	125	170	210	270	330
Anchor rod HIT-V, HIT-V-R, HIT-V-HCR	Anchor rods HIT-V (-R / -HCR) are available in variable length							

a) M30 and M36 please use anchor design software PROFIS anchor.

## Setting

### Installation equipment

Anchor size	M8	M10	M12	M16	M20	M24	M30
Rotary hammer	TE 2 – TE 30				TE 40 – TE 70		
Other tools	compressed air gun or blow out pump, set of cleaning brushes, dispenser						

## Setting instructions

### Bore hole drilling

#### a) Hilti hollow drill bit (for dry and wet concrete only)

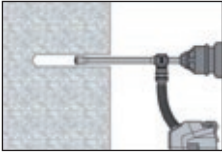

Drill hole to the required embedment depth with an appropriately sized Hilti TE-CD or TE-YD hollow drill bit with Hilti vacuum attachment. This drilling system removes the dust and cleans the bore hole while drilling when used in accordance with the user's manual.

After drilling is complete, proceed to the "injection preparation" step in the instructions for use.

#### b) Hammer drilling (dry or wet concrete and installation in flooded holes (no sea water))

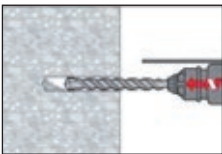

Drill Hole to the required embedment depth with a hammer drill set in rotation-hammer mode using an appropriately sized carbide drill bit.

### Bore hole cleaning Just before setting an anchor, the bore hole must be free of dust and debris.

#### a) Manual Cleaning (MC) for bore hole diameters $d_0 \leq 20\text{mm}$ and bore hole depth $h_0 \leq 20d$ or $h_0 \leq 250\text{ mm}$ ( $d = \text{diameter of element}$ )

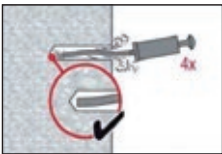

The Hilti manual pump may be used for blowing out bore holes up to diameters  $d_0 \leq 20\text{ mm}$  and embedment depths up to  $h_{ef} \leq 10d$ .

Blow out at least 4 times from the back of the bore hole until return air stream is free of noticeable dust

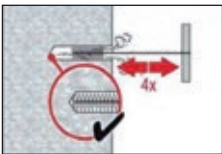

Brush 4 times with the specified brush size (brush  $\phi \geq \text{bore hole } \phi$ ) by inserting the steel brush Hilti HIT-RB to the back of the hole (if needed with extension) in a twisting motion and removing it.

The brush must produce natural resistance as it enters the bore hole -- if not the brush is too small and must be replaced with the proper brush diameter.

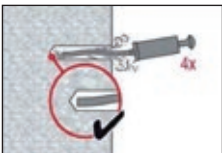

Blow out again with manual pump at least 4 times until return air stream is free of noticeable dust.

#### b) Compressed air cleaning (CAC) for all bore hole diameters $d_0$ and all bore hole depth $h_0$



Blow 2 times from the back of the hole (if needed with nozzle extension) over the hole length with oil-free compressed air (min. 6 bar at 6 m<sup>3</sup>/h) until return air stream is free of noticeable dust. Bore hole diameter  $\geq 32\text{ mm}$  the compressor must supply a minimum air flow of 140 m<sup>3</sup>/hour.

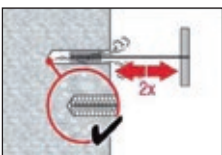

Brush 2 times with the specified brush size by inserting the steel brush Hilti HIT-RB to the back of the hole (if needed with extension) in a twisting motion and removing it.

The brush must produce natural resistance as it enters the bore hole -- if not the brush is too small and must be replaced with the proper brush diameter.



Blow again with compressed air 2 times until return air stream is free of noticeable dust.

## Setting instructions

**Bore hole cleaning** Just before setting an anchor, the bore hole must be free of dust and debris.

c) Cleaning for under water for all bore hole diameters  $d_0$  and all bore hole depth  $h_0$

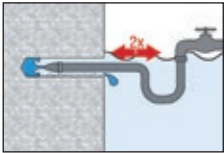

Flush 2 times the hole by inserting a water hose (water-line pressure) to the back of the hole until water runs clear.

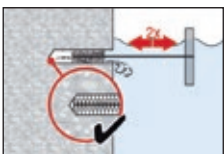

Brush 2 times with the specified brush size (brush  $\phi \geq$  bore hole  $\phi$ ) by inserting the steel brush Hilti HIT-RB to the back of the hole (if needed with extension) in a twisting motion and removing it.

The brush must produce natural resistance as it enters the bore hole -- if not the brush is too small and must be replaced with the proper brush diameter.

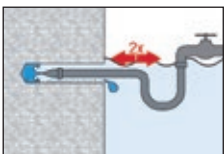

Flush the hole again 2 times by inserting a water hose (water-line pressure) to the back of the hole until water runs clear.

d) Cleaning of hammer drilled flooded holes for all bore hole diameters  $d_0$  and all bore hole depth  $h_0$

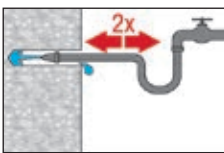

Flush 2 times the hole by inserting a water hose (water-line pressure) to the back of the hole until water runs clear.



Brush 2 times with the specified brush size (brush  $\phi \geq$  bore hole  $\phi$ ) by inserting the steel brush Hilti HIT-RB to the back of the hole (if needed with extension) in a twisting motion and removing it.

The brush must produce natural resistance as it enters the bore hole -- if not the brush is too small and must be replaced with the proper brush diameter.

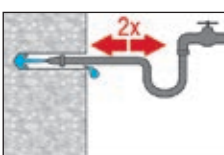

Flush 2 times the hole by inserting a water hose (water-line pressure) to the back of the hole until water runs clear.

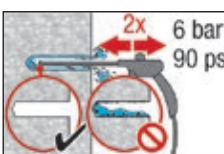

Blow 2 times from the back of the hole (if needed with nozzle extension) over the hole length with oil-free compressed air (min. 6 bar at 6 m<sup>3</sup>/h) until return air stream is free of noticeable dust and water

Bore hole diameter  $\geq$  32 mm the compressor must supply a minimum air flow of 140 m<sup>3</sup>/hour.

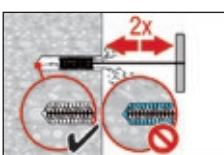

Brush 2 times with the specified brush size (brush  $\phi \geq$  bore hole  $\phi$ ) by inserting the steel brush Hilti HIT-RB to the back of the hole (if needed with extension) in a twisting motion and removing it.

The brush must produce natural resistance as it enters the bore hole -- if not the brush is too small and must be replaced with the proper brush diameter.

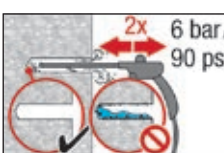

Blow again with compressed air 2 times until return air stream is free of noticeable dust.

## Setting instructions

### Injection preparation

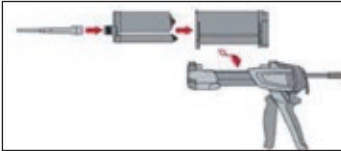

Tightly attach new Hilti mixing nozzle HIT-RE-M to foil pack manifold (snug fit). Do not modify the mixing nozzle. Observe the instruction for use of the dispenser. Check foil pack holder for proper function. Do not use damaged foil packs / holders. Swing foil pack holder with foil pack into HIT dispenser.

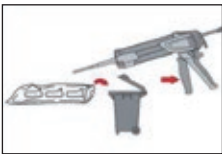

The foil pack opens automatically as dispensing is initiated. Discard initial adhesive. Depending on the size of the foil pack an initial amount of adhesive has to be discarded.

Discard quantities are:

3 strokes for 330 ml foil pack,

4 strokes for 500 ml foil pack

65 ml for 1400 ml foil pack

### Inject adhesive from the back of the borehole without forming air voids



Inject the adhesive starting at the back of the hole, slowly withdrawing the mixer with each trigger pull. Fill holes approximately 2/3 full. It is required that the annular gap between the anchor and the concrete is completely filled with adhesive along the embedment length.

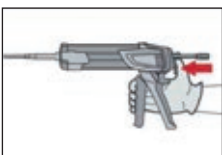

After injection is completed, depressurise the dispenser by pressing the release trigger. This will prevent further adhesive discharge from the mixer.

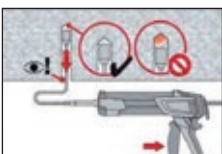

Overhead installation and/or installation with embedment depth  $h_{ef} > 250\text{mm}$ . For overhead installation the injection is only possible with the aid of extensions and piston plugs. Assemble HIT-RE-M mixer, extension(s) and appropriately sized piston plug HIT-SZ. Insert piston plug to back of the hole and inject adhesive. During injection the piston plug will be naturally extruded out of the bore hole by the adhesive pressure.

**Under water application:** fill bore hole completely with mortar

### Setting the element



Before use, verify that the element is dry and free of oil and other contaminants.

Mark and set element to the required embedment depth until working time  $t_{work}$  has elapsed

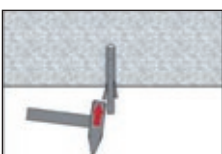

For overhead installation use piston plugs and fix embedded parts with e.g. wedges HIT-OHW

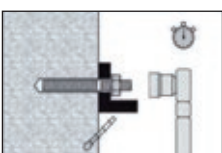

Loading the anchor:

After required curing time  $t_{cure}$  the anchor can be loaded.

The applied installation torque shall not exceed  $T_{max}$ .

## Curing time for general conditions

Data according ETA-07/0260, issue 2013-06-26		
Temperature of the base material	Working time in which anchor can be inserted and adjusted $t_{gel}$	Curing time before anchor can be fully loaded $t_{cure}$
40 °C	12 min	4 h
30 °C to 39 °C	12 min	8 h
20 °C to 29 °C	20 min	12 h
15 °C to 19 °C	30 min	24 h
10 °C to 14 °C	90 min	48 h
5 °C to 9 °C	120 min	72 h

For dry concrete curing times may be reduced according to the following table. For installation temperatures below +5 °C all load values have to be reduced according to the load reduction factors given below.

## Curing time for dry concrete

Additional Hilti technical data			
Temperature of the base material	Reduced curing time before anchor can be fully loaded $t_{cure,dry}$	Working time in which anchor can be inserted and adjusted $t_{gel}$	Load reduction factor
40 °C	4 h	12 min	1
30 °C	8 h	12 min	1
20 °C	12 h	20 min	1
15 °C	18 h	30 min	1
10 °C	24 h	90 min	1
5 °C	36 h	120 min	1
0 °C	50 h	3 h	0.7
-5 °C	72 h	4 h	0.6





## Setting details

Anchor size		Data according ETA-04/0027, issue 2013-06-26							Additional Hilti technical data
		M8	M10	M12	M16	M20	M24	M30	
Nominal diameter of drill bit	$d_0$ [mm]	10	12	14	18	24	28	35	40
Effective anchorage and drill hole depth range a)	$h_{ef,min}$ [mm]	40	40	48	64	80	96	120	144
	$h_{ef,max}$ [mm]	160	200	240	320	400	480	600	720
Minimum base material thickness	$h_{min}$ [mm]	$h_{ef} + 30 \text{ mm} \geq 100 \text{ mm}$			$h_{ef} + 2 d_0$				
Diameter of clearance hole in the fixture	$d_f$ [mm]	9	12	14	18	22	26	33	39
Minimum spacing	$s_{min}$ [mm]	40	50	60	80	100	120	150	180
Minimum edge distance	$c_{min}$ [mm]	40	50	60	80	100	120	150	180
Torque moment b)	$T_{max}^{b)}$ [Nm]	10	20	40	80	150	200	300	360

a)  $h_{ef,min} \leq h_{ef} \leq h_{ef,max}$  ( $h_{ef}$ : embedment depth)

b) This is the maximum recommended torque moment to avoid splitting during installation for anchors with minimum spacing and/or edge distance.

## Hilti HIT-RE 500 with HIT-V / HAS in diamond drilled holes

Injection Mortar System		Benefits
	Hilti HIT-RE 500 330 ml foil pack (also available as 500 ml and 1400 ml foil pack)	<ul style="list-style-type: none"> <li>■ suitable for non-cracked concrete C 20/25 to C 50/60</li> <li>■ high loading capacity</li> <li>■ suitable for dry and water saturated concrete</li> <li>■ under water application</li> <li>■ large diameter applications</li> <li>■ high corrosion resistant</li> <li>■ long working time at elevated temperatures</li> <li>■ odourless epoxy</li> <li>■ embedment depth range: from 40 ... 160 mm for M8 to 120 ... 600 mm for M30</li> </ul>
	Static mixer	
	HAS-E rod	
	HIT-V rods HIT-V (Zinc) HIT-V-F (Gal) HIT-V-R (A4-70) HIT-V-HCR rods	



Concrete



Small edge distance & spacing



Variable embedment depth



Corrosion resistance



High corrosion resistance



Diamond drilled holes



PROFIS anchor design software

### Approvals / certificates

Description	Authority / Laboratory	No. / date of issue
European technical approval a)	DIBt, Berlin	ETA-04/0027 / 2013-06-26
Fire test report	IBMB, Braunschweig	UB 3565 / 4595 / 2006-10-29 UB 3588 / 4825 / 2005-11-15
Assessment report (fire)	warringtonfire	WF 166402 / 2007-10-26 & suppl. WF 172920 / 2008-05-27

a) All data given in this section according ETA-04/0027, issue 2013-06-26.

### Service temperature range

Hilti HIT-RE 500 injection mortar may be applied in the temperature ranges given below. An elevated base material temperature may lead to a reduction of the design bond resistance.

Temperature range	Base material temperature	Maximum long term base material temperature	Maximum short term base material temperature
Temperature range I	-40 °C to +40 °C	+24 °C	+40 °C
Temperature range II	-40 °C to +58 °C	+35 °C	+58 °C
Temperature range III	-40 °C to +70 °C	+43 °C	+70 °C

#### Max short term base material temperature

Short-term elevated base material temperatures are those that occur over brief intervals, e.g. as a result of diurnal cycling.

#### Max long term base material temperature

Long-term elevated base material temperatures are roughly constant over significant periods of time



## Design process for typical anchor layouts

The design values in the tables are obtained from Profis V2.4.2 in compliance with the design method according to EOTA TR 029. Design resistance according to data given in ETA-04/0027, issue 2013-06-26.

- Influence of concrete strength
- Influence of edge distance
- Influence of spacing

The design method is based on the following simplification:

- No different loads are acting on individual anchors (no eccentricity)

The values are valid for the anchor configuration.

For more complex fastening applications please use the anchor design software PROFIS Anchor.

### STEP 1: TENSION LOADING

The design tensile resistance  $N_{Rd}$  is the lower of:

- Combined pull-out and concrete cone resistance

$$N_{Rd,p} = f_{B,p} \cdot N^*_{Rd,p}^1$$

$N^*_{Rd,p}$  is obtained from the relevant design tables

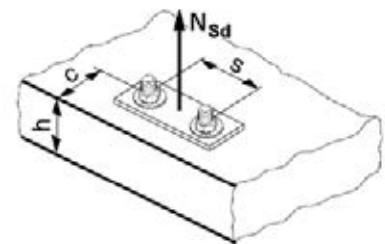

$f_{B,p}$  influence of concrete strength on combined pull-out and concrete cone resistance

Concrete Strengths $f'_{c,cyl}$ (MPa)	20	25	32	40	50
$f_{B,p}$	0.95	0.97	1.00	1.021	1.04

<sup>1</sup> Data apply for wet concrete and diamond cored holes.

For hammer drilled holes please see chapter "HIT-RE 500 with HIT-V / HAS rods in hammer drilled holes".

- Concrete cone or concrete splitting resistance

$$N_{Rd,c} = f_B \cdot N^*_{Rd,c}^2$$

$N^*_{Rd,c}$  is obtained from the relevant design tables

$f_B$  influence of concrete strength on concrete cone resistance

Concrete Strengths $f'_{c,cyl}$ (MPa)	20	25	32	40	50
$f_B$	0.79	0.87	1.00	1.11	1.22

<sup>2</sup> Data apply for wet concrete and diamond cored holes.

For hammer drilled holes please see chapter "HIT-RE 500 with HIT-V / HAS rods in hammer drilled holes".

- Design steel resistance (tension)  $N_{Rd,s}$

Anchor size		M8	M10	M12	M16	M20	M24	M30	
$N_{Rd,s}$	HAS - E 5.8	[kN]	11.3	17.3	25.3	48.0	74.7	106.7	-
	HIT-V 5.8	[kN]	12.0	19.3	28.0	52.7	82.0	118.0	187.3
	HIT-V 8.8	[kN]	19.3	30.7	44.7	84.0	130.7	188.0	299.3
	HAS-E-R	[kN]	12.3	19.8	28.3	54.0	84.0	119.8	92.0
	HIT-V-R	[kN]	13.9	21.9	31.6	58.8	92.0	132.1	98.3

$$N_{Rd} = \min \{ N_{Rd,p}, N_{Rd,c}, N_{Rd,s} \}$$

$$\text{CHECK } N_{Rd} \geq N_{Sd}$$

## STEP 2: SHEAR LOADING

The design shear resistance  $V_{Rd}$  is the lower of:

### ■ Design Concrete Edge Resistance

$$V_{Rd,c} = f_B \cdot V^*_{Rd,c}$$

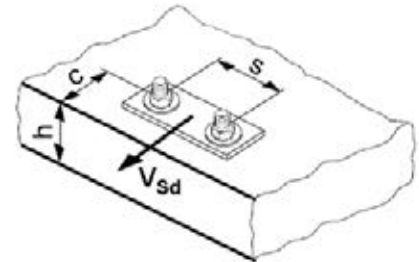

$V^*_{Rd,c}$  is obtained from the relevant design table

### $f_B$ influence of concrete strength

Concrete Strengths $f'_{c,cyl}$ (MPa)	20	25	32	40	50
$f_B$	0.79	0.87	1.00	1.11	1.22

#### Shear load acting parallel to edge:

These tables are for a single free edge only

#### 2 anchors:

For shear loads acting parallel to this edge, the concrete resistance  $V^*_{Rd,c}$  can be multiplied by the factor = 2.5

#### 4 anchors:

For shear loads acting parallel to the edge - the anchor row closest to the edge is checked to resist half the total design load.

To obtain the concrete resistance use the corresponding 2 anchor configuration  $V^*_{Rd,c}$  and multiply by the factor = 2.5

### ■ Design steel resistance (shear): $V_{Rd,s}$

Anchor size		M8	M10	M12	M16	M20	M24	M30
$V_{Rd,s}$ HAS - E 5.8	[kN]	6.8	10.4	15.2	28.8	44.8	64.0	-
HIT-V 5.8	[kN]	7.2	12.0	16.8	31.2	48.8	70.4	112.0
HIT-V 8.8	[kN]	12.0	18.4	27.2	50.4	78.4	112.8	179.2
HAS-E-R	[kN]	7.7	12,2	17.3	32.7	50.6	71.8	55.5
HIT-V-R	[kN]	8.3	12.8	19.2	35.3	55.1	79.5	58.8

$$V_{Rd} = \min \{ V_{Rd,c}, V_{Rd,s} \}$$

**CHECK  $V_{Rd} \geq V_{Sd}$**

## STEP 3: COMBINED TENSION AND SHEAR LOADING

The following equations must be satisfied:

$$N_{Sd}/N_{Rd} + V_{Sd}/V_{Rd} \leq 1.2$$

and

$$N_{Sd}/N_{Rd} \leq 1, V_{Sd}/V_{Rd} \leq 1$$

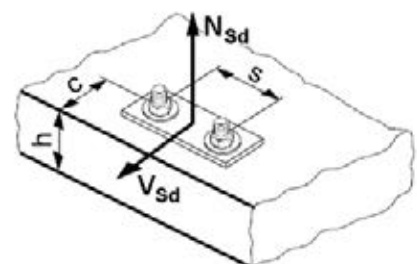



## Precalculated table values – design resistance values

### General:

The following tables provide the total ultimate limit state design resistance for the configurations. All tables are based upon:

- correct setting (See setting instruction)
- non-cracked concrete –  $f_{c,cyl} = 32$  MPa
- temperature range I (see service temperature range)
- base material thickness, as specified in the table
- One typical embedment depth, as specified in the tables
- wet concrete, diamond cored holes
- for hammer drilled holes please see chapter “HIT-RE 500 with HIT-V / HAS rods in hammer drilled holes”

The following tables give design values for typical embedment depths. The latest version of the Hilti software Profis allows the engineer to optimise their design by varying the embedment depth according to the applied loads to achieve an economical solution every time. This is done by selecting HIT-V-Rods.

For more information on the HIT V rods please refer to the Chemical Anchor Components & Accessories section on page 240. The anchor design software program Profis can be download from the Hilti Australia website, [www.hilti.com.au](http://www.hilti.com.au).

## Basic loading data (for a single anchor) – no edge distance and spacing influence

### Embedment depth and base material thickness for the basic loading data



Anchor size	M8	M10	M12	M16	M20	M24	M30
Typical embedment depth $h_{ef}$ [mm]	80	90	110	125	170	210	270
Base material thickness $h$ [mm]	110	120	150	200	250	300	350

### Design resistance [kN] - wet concrete, 32 Mpa

Anchor size		M8	M10	M12	M16	M20	M24	M30
Non-cracked concrete								
Tensile	Pull-out $N_{Rd,p}^*$	15.2	21.4	31.4	37.6	58.6	79.0	108.0
	Concrete $N_{Rd,c}^*$	25.4	30.3	40.9	42.5	67.4	92.6	135.0
Shear	$V_{Rd,s}$	Steel governed refer $V_{Rd,s}$ table						

## Basic loading data (for a single anchor) – with minimum edge distance

### Design resistance [kN] - wet concrete, 32 Mpa

Anchor size		M8	M10	M12	M16	M20	M24
Min. edge distance $c_{min}$ [mm]		40	50	60	80	100	120
Min Base thickness $h_{min}$ [mm]		110	120	150	200	250	300
<b>Tensile <math>N_{Rd}</math></b>							
	Pull-out $N_{Rd,p}^*$	8.5	12.0	17.7	22.2	34.1	47.0
	Concrete $N_{Rd,c}^*$	12.1	14.7	20.9	25.1	38.0	50.4
<b>Shear <math>V_{Rd}</math></b>							
	Shear (without lever arm) $V_{Rd,c}$	4.7	6.8	9.3	14.5	21.7	29.8

## Two Anchors

**Table 1:** One edge influence

Design Data:  $f_{c,cyl}=32$  MPa

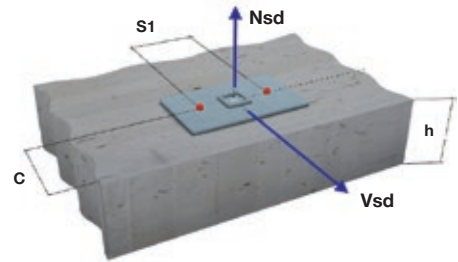

Anchor size	M8	M10	M12	M16	M20	M24
Typical embedment depth $h_{ef}$ [mm]	80	90	110	125	170	210
Base material thickness $h$ [mm]	110	120	150	200	250	300

ANCHOR <b>M8</b>	Edge C (mm)														
	40			80			100			150			170		
	tension		shear	tension		shear	tension		shear	tension		shear	tension		shear
spacing $s_1$ (mm)	$N^*_{Rd,p}$	$N^*_{Rd,c}$	$V^*_{Rd,c}$	$N^*_{Rd,p}$	$N^*_{Rd,c}$	$V^*_{Rd,c}$	$N^*_{Rd,p}$	$N^*_{Rd,c}$	$V^*_{Rd,c}$	$N^*_{Rd,p}$	$N^*_{Rd,c}$	$V^*_{Rd,c}$	$N^*_{Rd,p}$	$N^*_{Rd,c}$	$V^*_{Rd,c}$
40	11.4	13.5	6.3	16.6	17.6	13.1	19.5	19.8	15.4	20.4	25.8	21.0	20.4	28.4	23.2
80	12.8	14.9	7.9	18.6	19.4	15.0	21.9	21.8	17.2	22.8	28.5	22.7	22.8	31.4	24.9
100	13.5	15.6	8.7	19.6	20.3	15.9	23.0	22.9	18.1	24.0	29.9	23.9	24.0	32.9	25.8
120	14.1	16.4	9.4	20.6	21.2	16.9	24.2	23.9	19.0	25.2	31.2	24.5	25.2	34.4	26.6
150	15.1	17.4	9.4	22.0	22.6	18.3	25.9	25.5	20.4	27.0	33.2	25.7	27.0	36.6	27.9
200	16.8	19.2	9.4	24.4	24.9	20.6	28.6	28.1	22.7	29.8	36.6	27.9	29.8	40.3	30.0

ANCHOR <b>M10</b>	Edge C (mm)														
	50			80			100			150			200		
	tension		shear	tension		shear	tension		shear	tension		shear	tension		shear
spacing $s_1$ (mm)	$N^*_{Rd,p}$	$N^*_{Rd,c}$	$V^*_{Rd,c}$	$N^*_{Rd,p}$	$N^*_{Rd,c}$	$V^*_{Rd,c}$	$N^*_{Rd,p}$	$N^*_{Rd,c}$	$V^*_{Rd,c}$	$N^*_{Rd,p}$	$N^*_{Rd,c}$	$V^*_{Rd,c}$	$N^*_{Rd,p}$	$N^*_{Rd,c}$	$V^*_{Rd,c}$
50	15.6	16.6	9.0	19.8	19.7	15.0	22.7	21.9	17.5	27.9	27.8	23.4	27.9	34.1	29.3
100	17.6	18.4	11.3	22.3	21.9	17.6	25.6	24.3	19.9	31.4	30.9	25.8	31.4	38.0	31.6
150	19.6	20.3	13.5	24.8	24.1	20.2	28.5	26.8	22.4	35.0	34.0	28.1	35.0	41.8	33.8
200	21.6	22.2	13.5	27.3	26.3	22.8	31.4	29.2	24.9	38.5	37.2	30.5	38.5	45.6	36.1
250	23.5	24.0	13.5	29.7	28.5	24.9	34.2	31.7	27.4	41.9	40.3	32.8	41.9	49.4	38.3
300	24.0	25.9	13.5	30.4	30.7	24.9	35.0	34.1	29.9	42.8	43.4	35.1	42.8	53.8	40.6

ANCHOR <b>M12</b>	Edge C (mm)														
	60			80			100			150			200		
	tension		shear	tension		shear	tension		shear	tension		shear	tension		shear
spacing $s_1$ (mm)	$N^*_{Rd,p}$	$N^*_{Rd,c}$	$V^*_{Rd,c}$	$N^*_{Rd,p}$	$N^*_{Rd,c}$	$V^*_{Rd,c}$	$N^*_{Rd,p}$	$N^*_{Rd,c}$	$V^*_{Rd,c}$	$N^*_{Rd,p}$	$N^*_{Rd,c}$	$V^*_{Rd,c}$	$N^*_{Rd,p}$	$N^*_{Rd,c}$	$V^*_{Rd,c}$
60	22.6	23.5	12.3	25.8	25.9	16.7	29.2	28.5	21.4	38.6	35.2	28.3	40.2	42.6	35.0
100	24.6	25.3	14.4	28.1	27.9	18.9	31.8	30.6	23.8	42.0	37.8	30.5	43.8	45.8	37.1
150	27.1	27.5	17.0	30.9	30.3	21.7	35.0	33.3	26.8	46.3	41.1	33.2	48.2	49.8	39.8
200	29.6	29.7	18.5	33.8	32.8	24.5	38.3	35.9	29.8	50.6	44.5	36.0	52.7	53.8	42.4
250	32.0	31.9	18.5	36.6	35.2	26.7	41.5	38.6	32.7	54.8	47.8	38.8	57.1	57.8	45.1
300	34.5	34.1	18.5	39.4	37.6	26.7	44.6	41.3	35.7	58.9	51.1	41.6	61.4	61.8	47.7

ANCHOR <b>M16</b>	Edge C (mm)														
	80			100			150			200			250		
	tension		shear	tension		shear	tension		shear	tension		shear	tension		shear
spacing s1 (mm)	N*Rd,p	N*Rd,c	V*Rrd,c	N*Rd,p	N*Rd,c	V*Rrd,c	N*Rd,p	N*Rd,c	V*Rrd,c	N*Rd,p	N*Rd,c	V*Rrd,c	N*Rd,p	N*Rd,c	V*Rrd,c
80	27.9	30.5	19.4	31.2	34.0	24.4	40.0	43.6	36.2	47.3	51.6	44.1	47.3	51.6	52.0
100	29.1	33.7	20.6	32.4	35.5	25.7	41.6	45.6	37.6	49.2	53.8	45.4	49.2	53.8	53.2
150	31.9	36.9	23.6	35.6	39.2	28.9	45.7	50.4	41.0	54.0	59.5	48.7	54.0	59.5	56.4
200	34.7	38.5	26.6	38.7	43.0	32.1	49.7	55.1	44.4	58.7	65.2	51.9	58.7	65.2	59.5
250	37.5	41.8	29.1	41.9	46.7	35.3	53.7	59.9	47.8	63.5	70.9	55.2	63.5	70.9	62.6
300	40.3	45.2	29.1	45.0	50.5	38.6	57.7	64.4	51.2	68.2	76.5	58.4	68.2	76.5	65.7

ANCHOR <b>M20</b>	Edge C (mm)														
	120			150			200			250			300		
	tension		shear	tension		shear	tension		shear	tension		shear	tension		shear
spacing s1 (mm)	N*Rd,p	N*Rd,c	V*Rrd,c	N*Rd,p	N*Rd,c	V*Rrd,c	N*Rd,p	N*Rd,c	V*Rrd,c	N*Rd,p	N*Rd,c	V*Rrd,c	N*Rd,p	N*Rd,c	V*Rrd,c
100	42.9	45.9	28.9	52.8	51.6	44.1	63.7	60.0	55.6	73.7	69.0	64.6	73.7	78.6	73.6
150	46.2	46.6	32.5	56.9	54.9	48.1	68.7	63.9	59.5	79.4	73.5	68.4	79.4	83.7	77.2
200	49.5	53.4	36.2	61.0	58.3	52.1	73.6	67.8	63.5	85.1	78.0	72.2	85.1	88.8	80.9
250	52.8	52.3	39.8	65.1	61.7	56.1	78.6	71.8	67.5	90.8	82.5	76.0	90.8	94.0	84.6
300	56.2	55.2	43.4	69.2	65.0	60.0	83.5	75.7	71.4	96.5	87.0	79.8	96.5	99.1	88.3
350	59.5	58.0	43.4	73.3	68.4	64.1	88.4	79.6	75.4	102.2	91.5	83.6	102.2	104.3	92.0

ANCHOR <b>M24</b>	Edge C (mm)														
	120			150			200			250			350		
	tension		shear	tension		shear	tension		shear	tension		shear	tension		shear
spacing s1 (mm)	N*Rd,p	N*Rd,c	V*Rrd,c	N*Rd,p	N*Rd,c	V*Rrd,c	N*Rd,p	N*Rd,c	V*Rrd,c	N*Rd,p	N*Rd,c	V*Rrd,c	N*Rd,p	N*Rd,c	V*Rrd,c
120	59.8	57.5	39.8	66.8	62.3	49.7	79.3	70.7	67.5	92.8	79.5	77.6	100.5	98.6	97.6
150	62.2	59.3	42.3	69.5	64.2	52.3	82.5	72.9	70.3	96.5	82.0	80.3	104.5	101.7	100.1
200	66.1	62.3	46.4	73.9	67.5	56.7	87.7	76.5	75.0	102.7	86.1	84.7	111.2	106.8	104.3
250	70.1	65.2	50.6	78.3	70.7	61.0	93.0	80.1	79.7	108.8	90.2	89.2	117.9	111.8	108.5
300	74.1	68.2	54.7	82.8	73.9	65.4	98.3	83.8	84.4	115.0	94.3	93.7	124.5	116.9	112.6
350	78.0	71.1	58.9	87.2	77.1	69.7	103.5	87.4	89.1	121.1	98.4	98.1	131.2	122.0	116.8

## Four anchors

**Table 2:** One edge influence

Design Data:  $f_{c,cyl}=32$  MPa

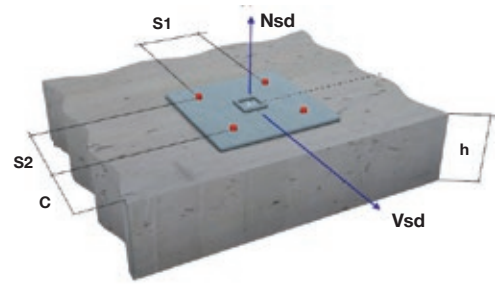

Anchor size	M8	M10	M12	M16	M20	M24
Typical embedment depth $h_{ef}$ [mm]	80	90	110	125	170	210
Base material thickness $h$ [mm]	110	120	150	200	250	300

ANCHOR <b>M8</b>	Edge C (mm)														
	40			80			100			150			200		
	tension		shear	tension		shear	tension		shear	tension		shear	tension		shear
spacing $s1=s2$ (mm)	$N^*_{Rd,p}$	$N^*_{Rd,c}$	$V^*_{Rd,c}$	$N^*_{Rd,p}$	$N^*_{Rd,c}$	$V^*_{Rd,c}$	$N^*_{Rd,p}$	$N^*_{Rd,c}$	$V^*_{Rd,c}$	$N^*_{Rd,p}$	$N^*_{Rd,c}$	$V^*_{Rd,c}$	$N^*_{Rd,p}$	$N^*_{Rd,c}$	$V^*_{Rd,c}$
40	16.9	16.1	12.6	23.4	20.4	17.7	27.0	22.7	19.9	28.0	29.0	25.4	28.0	31.7	30.9
80	22.0	20.6	15.8	29.6	25.6	23.8	33.7	28.3	26.0	34.9	35.6	31.5	34.9	38.7	36.8
100	24.8	23.1	17.4	32.9	28.5	26.9	37.4	31.3	29.0	38.6	39.2	34.4	38.6	42.5	39.8
120	27.7	25.7	18.8	36.3	31.4	29.9	41.1	34.5	32.0	42.4	42.9	37.4	42.4	46.5	42.7
150	32.2	29.9	18.8	41.7	36.2	34.3	46.9	39.6	36.4	48.3	48.8	41.8	48.3	52.7	47.0
200	40.1	37.5	18.8	51.0	44.9	41.2	57.0	48.9	43.7	58.6	59.5	49.0	58.6	64.1	54.2

ANCHOR <b>M10</b>	Edge C (mm)														
	50			80			100			150			200		
	tension		shear	tension		shear	tension		shear	tension		shear	tension		shear
spacing $s1=s2$ (mm)	$N^*_{Rd,p}$	$N^*_{Rd,c}$	$V^*_{Rd,c}$	$N^*_{Rd,p}$	$N^*_{Rd,c}$	$V^*_{Rd,c}$	$N^*_{Rd,p}$	$N^*_{Rd,c}$	$V^*_{Rd,c}$	$N^*_{Rd,p}$	$N^*_{Rd,c}$	$V^*_{Rd,c}$	$N^*_{Rd,p}$	$N^*_{Rd,c}$	$V^*_{Rd,c}$
50	22.4	19.9	17.5	27.4	23.2	21.0	31.0	25.5	23.4	37.2	31.8	29.3	37.2	38.4	35.1
100	29.7	25.9	22.6	35.6	29.8	29.2	39.8	32.5	31.6	47.0	39.8	37.3	47.0	47.5	43.0
150	37.8	32.6	27.0	44.7	37.1	37.2	49.6	40.2	39.5	57.9	48.7	45.1	57.9	57.6	50.8
200	46.7	40.0	27.0	54.6	45.2	45.0	60.2	48.8	47.3	69.7	58.5	52.8	69.7	68.6	58.4
250	56.2	48.2	27.0	65.2	54.1	49.8	71.5	58.2	54.8	82.2	69.2	60.5	82.2	80.6	66.0
300	58.9	57.2	27.0	68.1	63.8	49.8	74.7	68.5	59.8	85.6	80.8	68.1	85.6	93.6	73.6

ANCHOR <b>M12</b>	Edge C (mm)														
	60			80			100			150			200		
	tension		shear	tension		shear	tension		shear	tension		shear	tension		shear
spacing $s1=s2$ (mm)	$N^*_{Rd,p}$	$N^*_{Rd,c}$	$V^*_{Rd,c}$	$N^*_{Rd,p}$	$N^*_{Rd,c}$	$V^*_{Rd,c}$	$N^*_{Rd,p}$	$N^*_{Rd,c}$	$V^*_{Rd,c}$	$N^*_{Rd,p}$	$N^*_{Rd,c}$	$V^*_{Rd,c}$	$N^*_{Rd,p}$	$N^*_{Rd,c}$	$V^*_{Rd,c}$
60	31.6	28.3	24.2	35.5	30.9	26.9	39.6	33.5	29.6	50.7	40.7	36.3	52.6	48.5	42.9
100	38.6	33.8	28.8	43.0	36.7	34.5	47.6	39.7	37.1	60.0	47.6	43.7	62.1	56.3	50.2
150	48.3	41.4	34.0	53.3	44.7	43.4	58.6	48.1	46.2	72.7	57.1	52.7	75.1	66.9	59.1
200	58.8	49.8	37.0	64.5	53.5	49.0	70.5	57.3	55.2	86.5	67.5	61.6	89.2	78.5	67.9
250	70.2	58.9	37.0	76.6	63.0	53.4	83.3	67.3	64.0	101.3	78.7	70.3	104.3	90.9	76.6
300	82.3	68.7	37.0	89.5	73.4	53.4	97.0	78.1	71.4	116.9	90.8	79.0	120.3	104.3	85.3

**Shear design:** The concrete edge resistance value in this table uses all 4 anchors in shear. You will need to ensure the gap between anchor and the plate is filled. This can be achieved using the Hilti Dynamic Set. (Refer page 41 for further details)

The concrete edge resistance values have been obtained by taking the lesser of:

1. First row resistance multiplied by number of rows and
2. The concrete edge resistance of the furthest row.

ANCHOR <b>M16</b>	Edge C (mm)														
	80			100			150			200			250		
	tension		shear	tension		shear	tension		shear	tension		shear	tension		shear
spacing s1=s2 (mm)	N <sup>*</sup> Rd,p	N <sup>*</sup> Rd,c	V <sup>*</sup> Rrd,c	N <sup>*</sup> Rd,p	N <sup>*</sup> Rd,c	V <sup>*</sup> Rrd,c	N <sup>*</sup> Rd,p	N <sup>*</sup> Rd,c	V <sup>*</sup> Rrd,c	N <sup>*</sup> Rd,p	N <sup>*</sup> Rd,c	V <sup>*</sup> Rrd,c	N <sup>*</sup> Rd,p	N <sup>*</sup> Rd,c	V <sup>*</sup> Rrd,c
80	38.1	39.6	37.8	41.8	43.5	41.0	51.9	54.0	48.8	60.2	62.6	56.6	60.2	62.6	64.3
100	41.7	43.7	41.2	45.7	47.9	45.4	56.4	59.1	53.2	65.1	68.2	60.9	65.1	74.6	68.6
150	51.4	54.9	46.2	56.0	59.7	56.3	68.2	72.2	64.6	78.1	83.3	71.6	78.1	83.3	79.1
200	62.2	67.2	53.2	67.3	72.4	64.2	81.1	86.0	74.6	92.3	99.9	82.1	92.3	99.9	89.5
250	73.8	79.9	58.2	79.6	85.7	70.6	95.1	101.0	85.0	107.6	117.6	92.4	107.6	118.1	99.8
300	86.3	93.7	58.2	92.8	101.0	77.2	110.1	117.3	95.3	124.0	135.8	102.6	124.0	137.7	110.0

ANCHOR <b>M20</b>	Edge C (mm)														
	100			150			200			250			300		
	tension		shear	tension		shear	tension		shear	tension		shear	tension		shear
spacing s1=s2 (mm)	N <sup>*</sup> Rd,p	N <sup>*</sup> Rd,c	V <sup>*</sup> Rrd,c	N <sup>*</sup> Rd,p	N <sup>*</sup> Rd,c	V <sup>*</sup> Rrd,c	N <sup>*</sup> Rd,p	N <sup>*</sup> Rd,c	V <sup>*</sup> Rrd,c	N <sup>*</sup> Rd,p	N <sup>*</sup> Rd,c	V <sup>*</sup> Rrd,c	N <sup>*</sup> Rd,p	N <sup>*</sup> Rd,c	V <sup>*</sup> Rrd,c
100	58.5	53.8	55.6	70.0	62.2	64.6	82.5	71.2	73.6	93.9	80.8	82.4	93.9	91.0	91.2
150	69.5	62.7	65.0	82.3	72.0	77.2	96.2	81.9	86.0	108.8	92.4	94.8	108.8	103.6	103.4
200	81.4	72.3	72.4	95.6	82.5	89.6	110.9	93.3	98.3	124.7	104.8	106.9	124.7	117.0	115.5
250	94.2	82.5	79.6	109.8	93.7	101.8	126.6	105.5	110.3	141.7	118.0	118.9	141.8	131.2	127.3
300	107.8	93.4	86.8	124.9	105.5	113.8	143.3	118.3	122.3	159.8	131.9	130.7	159.8	146.2	139.1
350	122.2	105.0	86.8	140.9	118.1	125.6	160.9	132.0	134.1	178.8	146.6	142.4	178.8	162.0	150.8

ANCHOR <b>M24</b>	Edge C (mm)														
	120			150			200			250			350		
	tension		shear	tension		shear	tension		shear	tension		shear	tension		shear
spacing s1=s2 (mm)	N <sup>*</sup> Rd,p	N <sup>*</sup> Rd,c	V <sup>*</sup> Rrd,c	N <sup>*</sup> Rd,p	N <sup>*</sup> Rd,c	V <sup>*</sup> Rrd,c	N <sup>*</sup> Rd,p	N <sup>*</sup> Rd,c	V <sup>*</sup> Rrd,c	N <sup>*</sup> Rd,p	N <sup>*</sup> Rd,c	V <sup>*</sup> Rrd,c	N <sup>*</sup> Rd,p	N <sup>*</sup> Rd,c	V <sup>*</sup> Rrd,c
120	82.6	70.2	75.6	90.8	75.3	81.6	105.4	84.2	91.6	120.9	93.7	101.6	129.8	113.9	121.2
150	90.4	75.6	84.3	99.1	80.1	90.2	114.4	90.3	100.1	130.8	100.2	110.0	140.2	121.3	129.4
200	104.1	85.1	92.8	113.6	90.9	104.3	130.3	101.0	114.0	148.2	111.5	123.7	158.4	134.3	143.0
250	118.6	95.1	101.2	129.0	101.3	118.1	147.2	112.2	127.7	166.6	123.5	137.3	177.6	147.9	156.3
300	134.1	105.6	109.4	145.3	112.3	130.8	165.0	123.9	141.2	186.0	136.1	150.7	197.9	162.1	169.5
350	150.3	116.7	117.8	162.5	123.9	139.4	183.8	136.3	154.5	206.4	149.3	163.9	219.2	177.0	182.6

## Materials

### Mechanical properties of HIT-V / HAS

Anchor size			Data according ETA-04/0027, issue 2013-06-26							Additional Hilti technical data
			M8	M10	M12	M16	M20	M24	M30	M36
Nominal tensile strength $f_{uk}$	HIT-V/HAS 5.8 [N/mm <sup>2</sup> ]		500	500	500	500	500	500	500	500
	HIT-V/HAS 8.8 [N/mm <sup>2</sup> ]		800	800	800	800	800	800	800	800
	HIT-V/HAS -R [N/mm <sup>2</sup> ]		700	700	700	700	700	700	500	500
	HIT-V/HAS -HCR [N/mm <sup>2</sup> ]		800	800	800	800	800	700	700	500
Yield strength $f_{yk}$	HIT-V/HAS 5.8 [N/mm <sup>2</sup> ]		400	400	400	400	400	400	400	400
	HIT-V/HAS 8.8 [N/mm <sup>2</sup> ]		640	640	640	640	640	640	640	640
	HIT-V/HAS -R [N/mm <sup>2</sup> ]		450	450	450	450	450	450	210	210
	HIT-V/HAS -HCR [N/mm <sup>2</sup> ]		600	600	600	600	600	400	400	250
Stressed cross-section $A_s$	HAS [mm <sup>2</sup> ]		32.8	52.3	76.2	144	225	324	519	759
	HIT-V [mm <sup>2</sup> ]		36.6	58.0	84.3	157	245	353	561	817
Section Modulus $Z$	HAS [mm <sup>3</sup> ]		27.0	54.1	93.8	244	474	809	1706	2949
	HIT-V [mm <sup>3</sup> ]		31.2	62.3	109	277	541	935	1874	3294
<b>Steel failure with lever arm</b>			<b>M8</b>	<b>M10</b>	<b>M12</b>	<b>M16</b>	<b>M20</b>	<b>M24</b>	<b>M30</b>	<b>M36</b>
Design bending moment $M_{Rd,s}$	HIT-V-5.8 [Nm]		15	30	53	134	260	449	900	1581
	HIT-V-8.8 [Nm]		24	48	84	213	415	718	1439	2530
	HIT-V-R [Nm]		17	33	59	149	291	504	472	830
	HIT-V-HCR [Nm]		24	48	84	213	416	449	899	1129
	HAS-E-5.8 [Nm]		13	26	45	118	227	389	NA	NA
	HAS-E-8.8 [Nm]		NA	NA	NA	NA	NA	NA	1310	2265
	HAS-E-R [Nm]		15	29	51	131	255	436	430	743
	HAS-E-HCR [Nm]		21	42	72	187	364	389	819	1011

## Material quality

Part	Material
Threaded rod HIT-V(F), HAS 5.8 M8 – M24	Strength class 5.8, EN ISO 898-1, A5 > 8% ductile steel galvanized $\geq 5 \mu\text{m}$ , EN ISO 4042 (F) hot dipped galvanized $\geq 45 \mu\text{m}$ , EN ISO 10684
Threaded rod HIT-V(F), HAS 8.8 M27 – M39	Strength class 8.8, EN ISO 898-1, A5 > 8% ductile steel galvanized $\geq 5 \mu\text{m}$ , EN ISO 4042 (F) hot dipped galvanized $\geq 45 \mu\text{m}$ , EN ISO 10684
Threaded rod HIT-V-R, HAS-R	Stainless steel grade A4, A5 > 8% ductile strength class 70 for $\leq M24$ and class 50 for M27 to M30, EN ISO 3506-1, EN 10088: 1.4401
Threaded rod HIT-V-HCR, HAS-HCR	High corrosion resistant steel, EN ISO 3506-1, EN 10088: 1.4529; 1.4565 strength $\leq M20$ : $R_m = 800 \text{ N/mm}^2$ , $R_p 0.2 = 640 \text{ N/mm}^2$ , A5 > 8% ductile M24 to M30: $R_m = 700 \text{ N/mm}^2$ , $R_p 0.2 = 400 \text{ N/mm}^2$ , A5 > 8% ductile
Washer ISO 7089	Steel galvanized, EN ISO 4042; hot dipped galvanized, EN ISO 10684
	Stainless steel, EN 10088: 1.4401
	High corrosion resistant steel, EN 10088: 1.4529; 1.4565
Nut EN ISO 4032	Strength class 8, ISO 898-2 steel galvanized $\geq 5 \mu\text{m}$ , EN ISO 4042 hot dipped galvanized $\geq 45 \mu\text{m}$ , EN ISO 10684
	Strength class 70, EN ISO 3506-2, stainless steel grade A4, EN 10088: 1.4401
	Strength class 70, EN ISO 3506-2, high corrosion resistant steel, EN 10088: 1.4529; 1.4565

## Anchor dimensions

Anchor size	M8	M10	M12	M16	M20	M24	M30 <sup>a)</sup>	M36 <sup>a)</sup>
Anchor rod HAS, HAS-E, HAS-R, HAS-ER HAS-HCR	M8x80	M10x90	M12x110	M16x125	M20x170	M24x210	M30x270	M36x330
Anchor embedment depth [mm]	80	90	110	125	170	210	270	330
Anchor rod HIT-V, HIT-V-R, HIT-V-HCR	Anchor rods HIT-V (-R / -HCR) are available in variable length							

a) M30 and M36 please use anchor design software PROFIS anchor.

## Setting

### Installation equipment

Anchor size	M8	M10	M12	M16	M20	M24	M30
Drilling tools	DD EC-1, DD 100...DD XXX						
Other tools	compressed air gun or blow out pump, set of cleaning brushes, dispenser						

## Setting instructions

### Bore hole drilling

Diamond cored holes (for dry and wet concrete only)

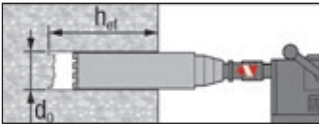

Diamond coring is permissible when diamond core drilling machine and the corresponding core bit are used.

### Bore hole cleaning

Just before setting an anchor, the bore hole must be free of dust and debris.

Cleaning of diamond cored hole for all bore hole diameters  $d_0$  and all bore hole depth  $h_0$

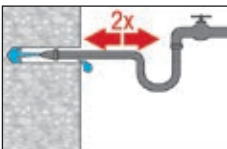

Flush 2 times the hole by inserting a water hose (water-line pressure) to the back of the hole until water runs clear.

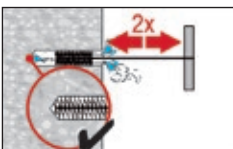

Brush 2 times with the specified brush size (brush  $\varnothing \geq$  bore hole  $\varnothing$ ) by inserting the steel brush Hilti HIT-RB to the back of the hole (if needed with extension) in a twisting motion and removing it.

The brush must produce natural resistance as it enters the bore hole -- if not the brush is too small and must be replaced with the proper brush diameter.

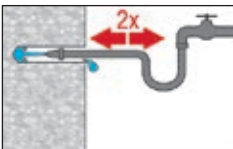

Flush 2 times the hole by inserting a water hose (water-line pressure) to the back of the hole until water runs clear.

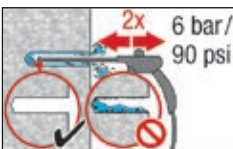

Blow 2 times from the back of the hole (if needed with nozzle extension) over the hole length with oil-free compressed air (min. 6 bar at 6 m<sup>3</sup>/h) until return air stream is free of noticeable dust and water

Bore hole diameter  $\geq$  32 mm the compressor must supply a minimum air flow of 140 m<sup>3</sup>/hour.

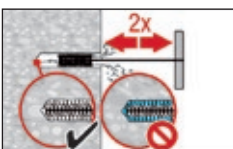

Brush 2 times with the specified brush size (brush  $\varnothing \geq$  bore hole  $\varnothing$ ) by inserting the steel brush Hilti HIT-RB to the back of the hole (if needed with extension) in a twisting motion and removing it.

The brush must produce natural resistance as it enters the bore hole -- if not the brush is too small and must be replaced with the proper brush diameter.

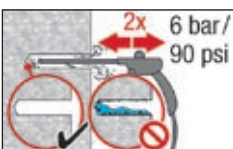

Blow again with compressed air 2 times until return air stream is free of noticeable dust.



## Setting instructions

### Injection preparation

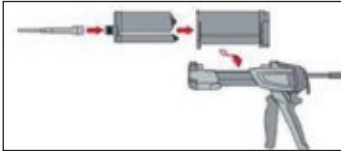

Tightly attach new Hilti mixing nozzle HIT-RE-M to foil pack manifold (snug fit). Do not modify the mixing nozzle. Observe the instruction for use of the dispenser. Check foil pack holder for proper function. Do not use damaged foil packs / holders. Swing foil pack holder with foil pack into HIT dispenser.

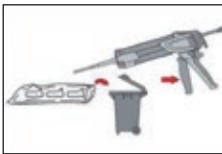

The foil pack opens automatically as dispensing is initiated. Discard initial adhesive. Depending on the size of the foil pack an initial amount of adhesive has to be discarded.

Discard quantities are:

3 strokes for 330 ml foil pack,

4 strokes for 500 ml foil pack

65 ml for 1400 ml foil pack

### Inject adhesive from the back of the borehole without forming air voids



Inject the adhesive starting at the back of the hole, slowly withdrawing the mixer with each trigger pull. Fill holes approximately 2/3 full. It is required that the annular gap between the anchor and the concrete is completely filled with adhesive along the embedment length.

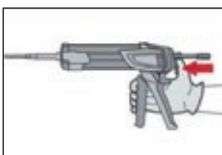

After injection is completed, depressurise the dispenser by pressing the release trigger. This will prevent further adhesive discharge from the mixer.

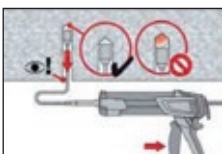

Overhead installation and/or installation with embedment depth  $h_{ef} > 250\text{mm}$ . For overhead installation the injection is only possible with the aid of extensions and piston plugs. Assemble HIT-RE-M mixer, extension(s) and appropriately sized piston plug HIT-SZ. Insert piston plug to back of the hole and inject adhesive. During injection the piston plug will be naturally extruded out of the bore hole by the adhesive pressure.

**Under water application:** fill bore hole completely with mortar

### Setting the element

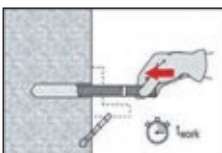

Before use, verify that the element is dry and free of oil and other contaminants.

Mark and set element to the required embedment depth until working time  $t_{work}$  has elapsed

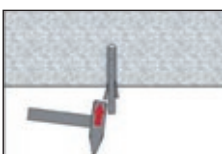

For overhead installation use piston plugs and fix embedded parts with e.g. wedges HIT-OHW

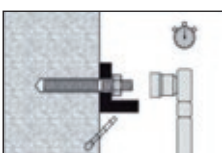

Loading the anchor:

After required curing time  $t_{cure}$  the anchor can be loaded.

The applied installation torque shall not exceed  $T_{max}$ .

## Curing time for general conditions

Data according ETA-07/0260, issue 2013-06-26		
Temperature of the base material	Working time in which anchor can be inserted and adjusted $t_{gel}$	Curing time before anchor can be fully loaded $t_{cure}$
40 °C	12 min	4 h
30 °C to 39 °C	12 min	8 h
20 °C to 29 °C	20 min	12 h
15 °C to 19 °C	30 min	24 h
10 °C to 14 °C	90 min	48 h
5 °C to 9 °C	120 min	72 h



## Setting details

Anchor size			Data according ETA-04/0027, issue 2013-06-26							Additional Hilti technical data
			M8	M10	M12	M16	M20	M24	M30	
Nominal diameter of drill bit	$d_0$	[mm]	10	12	14	18	24	28	35	40
Effective anchorage and drill hole depth range a)	$h_{ef,min}$	[mm]	40	40	48	64	80	96	120	144
	$h_{ef,max}$	[mm]	160	200	240	320	400	480	600	720
Minimum base material thickness	$h_{min}$	[mm]	$h_{ef} + 30 \text{ mm} \geq 100 \text{ mm}$			$h_{ef} + 2 d_0$				
Diameter of clearance hole in the fixture	$d_f$	[mm]	9	12	14	18	22	26	33	39
Minimum spacing	$s_{min}$	[mm]	40	50	60	80	100	120	150	180
Minimum edge distance	$c_{min}$	[mm]	40	50	60	80	100	120	150	180
Torque moment b)	$T_{max}^{b)}$	[Nm]	10	20	40	80	150	200	300	360

a)  $h_{ef,min} \leq h_{ef} \leq h_{ef,max}$  ( $h_{ef}$ : embedment depth)

b) This is the maximum recommended torque moment to avoid splitting during installation for anchors with minimum spacing and/or edge distance.

## Hilti HIT-RE 500 with rebar in hammer drilled holes

Injection Mortar System	Benefits
 <p>Hilti HIT-RE 500 330 ml foil pack (also available as 500 ml and 1400 ml foil pack)</p>  <p>Static mixer</p>  <p>Rebar BSt 500 S</p>	<ul style="list-style-type: none"> <li>■ suitable for non-cracked concrete C 20/25 to C 50/60</li> <li>■ high loading capacity</li> <li>■ suitable for dry and water saturated concrete</li> <li>■ under water application</li> <li>■ large diameter applications</li> <li>■ high corrosion resistant</li> <li>■ long working time at elevated temperatures</li> <li>■ odourless epoxy</li> <li>■ embedment depth range: from 60 ... 160 mm for Ø8 to 128 ... 640 mm for Ø32</li> </ul>



Concrete



Small edge distance & spacing



Variable embedment depth



European Technical Approval



CE conformity



PROFIS anchor design software



SAFEset approved automatic cleaning

### Approvals / certificates

Description	Authority / Laboratory	No. / date of issue
European technical approval a)	DIBt, Berlin	ETA-04/0027 / 2013-06-26

a) All data given in this section according ETA-04/0027, issue 2013-06-26.

### Service temperature range

Hilti HIT-RE 500 injection mortar may be applied in the temperature ranges given below. An elevated base material temperature may lead to a reduction of the design bond resistance.

Temperature range	Base material temperature	Maximum long term base material temperature	Maximum short term base material temperature
Temperature range I	-40 °C to +40 °C	+24 °C	+40 °C
Temperature range II	-40 °C to +58 °C	+35 °C	+58 °C
Temperature range III	-40 °C to +70 °C	+43 °C	+70 °C

#### Max short term base material temperature

Short-term elevated base material temperatures are those that occur over brief intervals, e.g. as a result of diurnal cycling.

#### Max long term base material temperature

Long-term elevated base material temperatures are roughly constant over significant periods of time

## Design process for typical anchor layouts

The design values in the tables are obtained from Profis V2.4.2 in compliance with the design method according to EOTA TR 029. Design resistance according to data given in ETA-04/0027, issue 2013-06-26.

- Influence of concrete strength
- Influence of edge distance
- Influence of spacing

The design method is based on the following simplification:

- No different loads are acting on individual anchors (no eccentricity)

The values are valid for the anchor configuration.

For more complex fastening applications please use the anchor design software PROFIS Anchor.

### STEP 1: TENSION LOADING

The design tensile resistance  $N_{Rd}$  is the lower of:

- Combined pull-out and concrete cone resistance

$$N_{Rd,p} = f_{B,p} \cdot N^*_{Rd,p}{}^1$$

$N^*_{Rd,p}$  is obtained from the relevant design tables

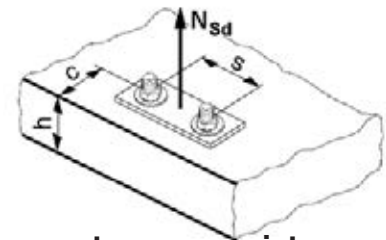

$f_{B,p}$  influence of concrete strength on combined pull-out and concrete cone resistance

Concrete Strengths $f'_{c,cyl}$ (MPa)	20	25	32	40	50
$f_{B,p}$	0.95	0.97	1.00	1.02	1.04

1 Data apply for dry concrete and hammer drilled holes only. For non-dry concrete multiply  $N_{Rd,p}$  by the factor 0.83. For diamond cored holes please see chapter "HIT-RE 500 with rebar in diamond cored holes"

- Concrete cone or concrete splitting resistance

$$N_{Rd,c} = f_B \cdot N^*_{Rd,c}{}^2$$

$N^*_{Rd,c}$  is obtained from the relevant design tables

$f_B$  influence of concrete strength on concrete cone resistance

Concrete Strengths $f'_{c,cyl}$ (MPa)	20	25	32	40	50
$f_B$	0.79	0.87	1.00	1.11	1.22

2 For non dry concrete multiply  $N_{Rd,c}$  by the factor 0.83.

The definition of Dry Concrete, as per Hilti is: concrete not in contact with water before/during installation and curing.

- Design steel resistance  $N_{Rd,s}$

Anchor size	Ø8	Ø10	Ø12	Ø14	Ø16	Ø20	Ø24	Ø28	Ø32
$N_{Rd,s}$ BSt 500 S [kN]	20.0	30.7	44.3	60.7	79.3	123.6	177.8	242.1	315.7

$$N_{Rd} = \min \{ N_{Rd,p}, N_{Rd,c}, N_{Rd,s} \}$$

$$\text{CHECK } N_{Rd} \geq N_{Sd}$$

## STEP 2: SHEAR LOADING

The design shear resistance  $V_{Rd}$  is the lower of:

### ■ Design Concrete Edge Resistance

$$V_{Rd,c} = f_B \cdot V^*_{Rd,c}$$

$V^*_{Rd,c}$  is obtained from the relevant design table

### $f_B$ influence of concrete strength

Concrete Strengths $f'_{c,cyl}$ (MPa)	20	25	32	40	50
$f_B$	0.79	0.87	1.00	1.11	1.22

### Shear load acting parallel to edge:

These tables are for a single free edge only

#### 2 anchors:

For shear loads acting parallel to this edge, the concrete resistance  $V^*_{Rd,c}$  can be multiplied by the factor = 2.5

#### 4 anchors:

For shear loads acting parallel to the edge - the anchor row closest to the edge is checked to resist half the total design load.

To obtain the concrete resistance use the corresponding 2 anchor configuration  $V^*_{Rd,c}$  and multiply by the factor = 2.5

### ■ Design steel resistance $V_{Rd,s}$

Anchor size	Ø8	Ø10	Ø12	Ø14	Ø16	Ø20	Ø24	Ø28	Ø32
$V_{Rd,s}$ BSt 500 S [kN]	9.3	14.7	20.7	28.0	36.7	57.3	83.0	112.7	147.3

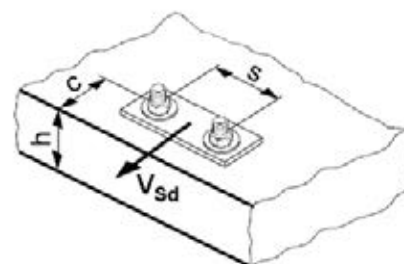

$$V_{Rd} = \min \{ V_{Rd,c}, V_{Rd,s} \}$$

**CHECK  $V_{Rd} \geq V_{Sd}$**

## STEP 3: COMBINED TENSION AND SHEAR LOADING

The following equations must be satisfied:

$$N_{Sd}/N_{Rd} + V_{Sd}/V_{Rd} \leq 1.2$$

and

$$N_{Sd}/N_{Rd} \leq 1, V_{Sd}/V_{Rd} \leq 1$$

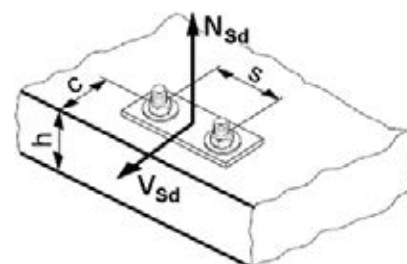

## Precalculated table values – design resistance values

### General:

The following tables provide the total ultimate limit state design resistance for the configurations.

All tables are based upon:

- correct setting (See setting instruction)
- non-cracked concrete –  $f_{c,cyl} = 32 \text{ MPa}$
- temperature range I (see service temperature range)
- base material thickness, as specified in the table
- Three typical embedment depths, as specified in the tables
- dry concrete, hammer drilled hole
- for non-dry concrete multiply values by the factor 0.83
- for diamond cored holes please see chapter “HIT-RE 500 with rebar in diamond cored holes”

The following tables give design values for typical embedment depths. The latest version of the Hilti software Profis allows the engineer to optimise their design by varying the embedment depth according to the applied loads to achieve an economical solution every time. This is done by selecting rebar.

The anchor design software program Profis can be download from the Hilti Australia website, [www.hilti.com.au](http://www.hilti.com.au).

## Single anchor - dry concrete - no edge and spacing influences

### Embedment 1

Design Resistance $f_{c,cyl} - 32\text{Mpa}$									
Rebar size		Ø8	Ø10	Ø12	Ø16	Ø20	Ø24	Ø28	Ø32
Embedment depth	[mm]	60	60	72	96	120	144	168	192
Base material thickness	[mm]	100	100	104	136	170	210	238	272
<b>Tensile Single anchor no edge</b>									
Pull-out	$N_{Rd,p}^*$ [kN]	13.6	16.9	24.4	40.4	63.1	88.0	115.1	150.2
Concrete	$N_{Rd,c}^*$ [kN]	16.9	16.9	22.2	34.3	48.0	63.0	79.4	97.1
<b>Shear Single anchor no edge</b>									
Shear	$V_{Rd,s}$ [kN]	9.3	14.7	20.7	36.7	57.3	83.0	112.7	147.3

### Embedment 2



Design Resistance $f_{c,cyl} - 32\text{Mpa}$									
Rebar size		Ø8	Ø10	Ø12	Ø16	Ø20	Ø24	Ø28	Ø32
Embedment depth	[mm]	80	90	110	125	170	210	270	300
Base material thickness	[mm]	110	120	142	165	220	270	340	380
<b>Tensile Single anchor no edge</b>									
Pull-out	$N_{Rd,p}^*$ [kN]	18.0	25.4	37.2	52.7	89.5	128.4	184.9	234.8
Concrete	$N_{Rd,c}^*$ [kN]	26.0	31.2	42.0	51.0	80.9	111.0	161.9	189.6
<b>Shear Single anchor no edge</b>									
Shear	$V_{Rd,s}$ [kN]	9.3	14.7	20.7	36.7	57.3	83.0	112.7	147.3

### Embedment 3



Design Resistance $f_{c,cyl} - 32\text{Mpa}$									
Rebar size		Ø8	Ø10	Ø12	Ø16	Ø20	Ø24	Ø28	Ø32
Embedment depth	[mm]	96	120	144	192	240	288	336	384
Base material thickness	[mm]	126	150	176	232	290	348	406	464
<b>Tensile Single anchor no edge</b>									
Pull-out	$N_{Rd,p}^*$ [kN]	21.7	33.8	48.7	80.9	126.4	176.0	230.0	300.5
Concrete	$N_{Rd,c}^*$ [kN]	34.3	48.0	63.1	97.1	135.7	178.3	224.8	274.7
<b>Shear Single anchor no edge</b>									
Shear	$V_{Rd,s}$ [kN]	9.3	14.7	20.7	36.7	57.3	83.0	112.7	147.3

## Single anchor - minimum edge distance influence



### Embedment 1

Design Resistance $f_{c,cyl}$ - 32Mpa											
Rebar size		Ø8	Ø10	Ø12	Ø16	Ø20	Ø24	Ø28	Ø32		
Embedment depth [mm]		60	60	72	96	120	144	168	192		
Base material thickness [mm]		100	100	104	136	170	210	238	272		
Edge Dist $c = c_{min}$ [mm]		40	50	60	80	100	120	140	160		
Tensile Single anchor min edge											
	Pull-out	$N_{Rd,p}^*$	[kN]	8.2	11.4	16.4	27.2	42.6	60.7	77.5	101.3
	Concrete	$N_{Rd,c}^*$	[kN]	9.8	11.0	13.0	19.8	27.7	37.9	46.0	56.2
Shear Single anchor min edge											
	Shear (without lever arm)	$V_{Rd,c}$	[kN]	4.4	6.2	8.4	13.6	19.9	28.6	35.0	43.8

### Embedment 2

Design Resistance $f_{c,cyl}$ - 32Mpa											
Rebar size		Ø8	Ø10	Ø12	Ø16	Ø20	Ø24	Ø28	Ø32		
Embedment depth [mm]		80	90	110	125	170	210	270	300		
Base material thickness [mm]		110	120	142	165	220	270	340	380		
Edge Dist $c = c_{min}$ [mm]		40	50	60	80	100	125	140	160		
Tensile Single anchor min edge											
	Pull-out	$N_{Rd,p}^*$	[kN]	9.8	14.0	20.5	31.1	50.9	73.4	103.8	131.5
	Concrete	$N_{Rd,c}^*$	[kN]	12.5	15.1	20.2	25.8	39.6	54.7	76.4	90.2
Shear Single anchor min edge											
	Shear (without lever arm)	$V_{Rd,c}$	[kN]	4.7	6.7	9.3	14.5	21.7	31.6	40.0	49.8

### Embedment 3

Design Resistance $f_{c,cyl}$ - 32Mpa											
Rebar size		Ø8	Ø10	Ø12	Ø16	Ø20	Ø24	Ø28	Ø32		
Embedment depth [mm]		96	120	144	192	240	288	336	384		
Base material thickness [mm]		126	150	176	232	290	348	406	464		
Edge Dist $c = c_{min}$ [mm]		40	50	60	80	100	125	140	160		
Tensile Single anchor min edge											
	Pull-out	$N_{Rd,p}^*$	[kN]	11.8	18.5	26.5	44.8	69.8	98.9	129.2	168.7
	Concrete	$N_{Rd,c}^*$	[kN]	15.4	21.5	28.2	43.4	60.7	82.3	100.6	122.8
Shear Single anchor min edge											
	Shear (without lever arm)	$V_{Rd,c}$	[kN]	4.9	7.2	9.9	16.3	23.9	34.7	42.8	53.9

## 2 Anchors - min spacing influence

### Embedment 1

Design Resistance $f_{c,cyl} - 32\text{Mpa}$											
Rebar size		Ø8	Ø10	Ø12	Ø16	Ø20	Ø24	Ø28	Ø32		
Embedment depth	[mm]	60	60	72	96	120	144	168	192		
Base material thicknes	[mm]	100	100	104	136	170	210	238	272		
Spacing Dist $s = s_{min}$	[mm]	40	50	60	80	100	125	140	160		
Tensile $N_{Rd}$											
	Pull-out	$N_{Rd,p}^*$	[kN]	17.5	21.6	31.2	51.6	80.8	113.5	147.0	101.3
	Concrete	$N_{Rd,c}^*$	[kN]	20.5	21.4	26.9	41.3	57.7	77.4	95.6	56.2
Shear $V_{Rd}$											
$V_{Rd,s}$ steel (per anchor)	[kN]	9.3	14.7	20.7	36.7	57.3	83.0	112.6	147.3		
$V_{Rd,s}$ pryout	[kN]	N/A				113.0	190.0	236.9	289.5		

### Embedment 2

Design Resistance $f_{c,cyl} - 32\text{Mpa}$											
Rebar size		Ø8	Ø10	Ø12	Ø16	Ø20	Ø24	Ø28	Ø32		
Embedment depth	[mm]	80	90	110	125	170	210	270	300		
Base material thicknes	[mm]	110	120	142	165	220	270	340	380		
Spacing Dist $s = s_{min}$	[mm]	40	50	60	80	100	125	140	160		
Tensile $N_{Rd}$											
	Pull-out	$N_{Rd,p}^*$	[kN]	23.4	31.9	45.7	64.0	107.2	151.4	220.0	279.4
	Concrete	$N_{Rd,c}^*$	[kN]	29.2	35.0	47.2	58.3	91.4	125.8	180.5	211.9
Shear $V_{Rd}$											
$V_{Rd,s}$ steel (per anchor)	[kN]	9.3	14.7	20.7	36.7	57.3	83.0	112.6	147.3		

### Embedment 3

Design Resistance $f_{c,cyl} - 32\text{Mpa}$											
Rebar size		Ø8	Ø10	Ø12	Ø16	Ø20	Ø24	Ø28	Ø32		
Embedment depth	[mm]	96	120	144	192	240	288	336	384		
Base material thicknes	[mm]	126	150	176	232	290	348	406	464		
Spacing Dist $s = s_{min}$	[mm]	40	50	60	80	100	125	140	160		
Tensile $N_{Rd}$											
	Pull-out	$N_{Rd,p}^*$	[kN]	28.4	43.7	61.7	101.0	152.9	210.1	273.8	357.6
	Concrete	$N_{Rd,c}^*$	[kN]	37.4	52.4	68.9	106.1	148.2	199.9	245.5	300.0
Shear $V_{Rd}$											
$V_{Rd,s}$ steel (per anchor)	[kN]	9.3	14.7	20.7	36.7	57.3	83.0	112.6	147.3		



## Materials

### Mechanical properties of rebar BSt 500S

Anchor size			Ø8	Ø10	Ø12	Ø14	Ø16	Ø20	Ø24	Ø28	Ø32
Nominal tensile strength $f_{uk}$	BSt 500 S	[N/mm <sup>2</sup> ]	550	550	550	550	550	550	550	550	550
Yield strength $f_{yk}$	BSt 500 S	[N/mm <sup>2</sup> ]	500	500	500	500	500	500	500	500	500
Stressed cross-section $A_s$	BSt 500 S	[mm <sup>2</sup> ]	50.3	78.5	113.1	153.9	201.1	314.2	452.0	615.8	804.2
Moment of resistance	BSt 500 S	[mm <sup>3</sup> ]	50.3	98.2	169.6	269.4	402.1	785.4	1415	2155	3217

## Material quality

Part	Material
rebar BSt 500 S	Geometry and mechanical properties according to DIN 488-2:1986 or E DIN 488-2:2006

## Setting

### installation equipment

Anchor size	Ø8	Ø10	Ø12	Ø14	Ø16	Ø20	Ø25	Ø28	Ø32
Rotary hammer	TE 2 - TE 30					TE 40- TE 70			
Other tools	compressed air gun or blow out pump, set of cleaning brushes, dispenser								

## Setting instructions

### Bore hole drilling

#### a) Hilti hollow drill bit (for dry and wet concrete only)

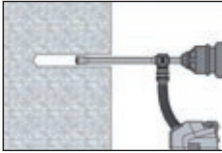

Drill hole to the required embedment depth with an appropriately sized Hilti TE-CD or TE-YD hollow drill bit with Hilti vacuum attachment. This drilling system removes the dust and cleans the bore hole while drilling when used in accordance with the user's manual.

After drilling is complete, proceed to the "injection preparation" step in the instructions for use.

#### b) Hammer drilling (dry or wet concrete and installation in flooded holes (no sea water))

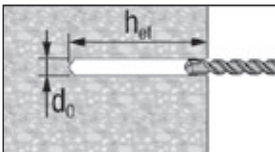

Drill Hole to the required embedment depth with a hammer drill set in rotation-hammer mode using an appropriately sized carbide drill bit.

### Bore hole cleaning Just before setting an anchor, the bore hole must be free of dust and debris.

#### a) Manual Cleaning (MC) for bore hole diameters $d_0 \leq 20\text{mm}$ and bore hole depth $h_0 \leq 20d$ or $h_0 \leq 250\text{ mm}$ ( $d$ = diameter of element)

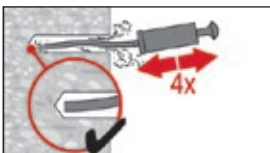

The Hilti manual pump may be used for blowing out bore holes up to diameters  $d_0 \leq 20\text{ mm}$  and embedment depths up to  $h_{ef} \leq 10d$ . Blow out at least 4 times from the back of the bore hole until return air stream is free of noticeable dust

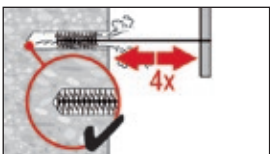

Brush 4 times with the specified brush size (brush  $\phi \geq$  bore hole  $\phi$ ) by inserting the steel brush Hilti HIT-RB to the back of the hole (if needed with extension) in a twisting motion and removing it.

The brush must produce natural resistance as it enters the bore hole -- if not the brush is too small and must be replaced with the proper brush diameter.

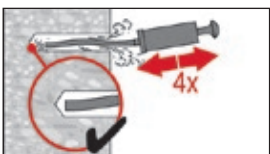

Blow out again with manual pump at least 4 times until return air stream is free of noticeable dust.

#### b) Compressed air cleaning (CAC) for all bore hole diameters $d_0$ and all bore hole depth $h_0$

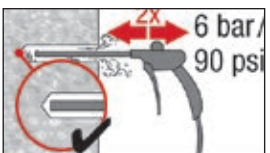

Blow 2 times from the back of the hole (if needed with nozzle extension) over the hole length with oil-free compressed air (min. 6 bar at  $6\text{ m}^3/\text{h}$ ) until return air stream is free of noticeable dust. Bore hole diameter  $\geq 32\text{ mm}$  the compressor must supply a minimum air flow of  $140\text{ m}^3/\text{hour}$ .

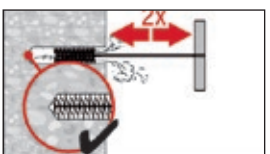

Brush 2 times with the specified brush size by inserting the steel brush Hilti HIT-RB to the back of the hole (if needed with extension) in a twisting motion and removing it.

The brush must produce natural resistance as it enters the bore hole -- if not the brush is too small and must be replaced with the proper brush diameter.

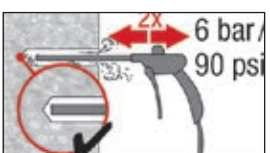

Blow again with compressed air 2 times until return air stream is free of noticeable dust.

## Setting instructions

### Bore hole cleaning Just before setting an anchor, the bore hole must be free of dust and debris.

#### c) Cleaning for under water for all bore hole diameters $d_0$ and all bore hole depth $h_0$

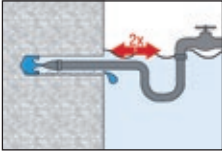

Flush 2 times the hole by inserting a water hose (water-line pressure) to the back of the hole until water runs clear.

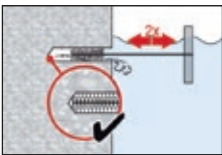

Brush 2 times with the specified brush size (brush  $\varnothing \geq$  bore hole  $\varnothing$ ) by inserting the steel brush Hilti HIT-RB to the back of the hole (if needed with extension) in a twisting motion and removing it.

The brush must produce natural resistance as it enters the bore hole -- if not the brush is too small and must be replaced with the proper brush diameter.

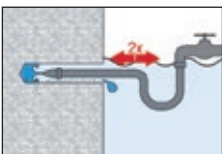

Flush the hole again 2 times by inserting a water hose (water-line pressure) to the back of the hole until water runs clear.

#### d) Cleaning of hammer drilled flooded holes for all bore hole diameters $d_0$ and all bore hole depth $h_0$

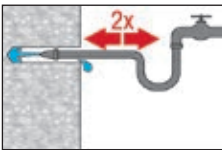

Flush 2 times the hole by inserting a water hose (water-line pressure) to the back of the hole until water runs clear.

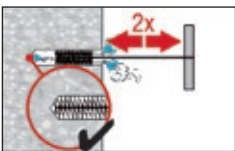

Brush 2 times with the specified brush size (brush  $\varnothing \geq$  bore hole  $\varnothing$ ) by inserting the steel brush Hilti HIT-RB to the back of the hole (if needed with extension) in a twisting motion and removing it.

The brush must produce natural resistance as it enters the bore hole -- if not the brush is too small and must be replaced with the proper brush diameter.

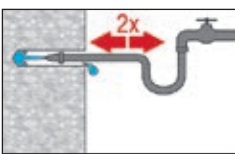

Flush 2 times the hole by inserting a water hose (water-line pressure) to the back of the hole until water runs clear.

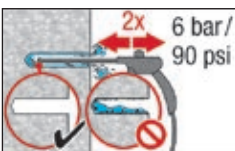

Blow 2 times from the back of the hole (if needed with nozzle extension) over the hole length with oil-free compressed air (min. 6 bar at 6 m<sup>3</sup>/h) until return air stream is free of noticeable dust and water

Bore hole diameter  $\geq$  32 mm the compressor must supply a minimum air flow of 140 m<sup>3</sup>/hour.

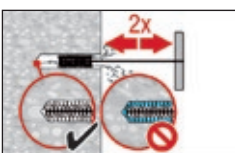

Brush 2 times with the specified brush size (brush  $\varnothing \geq$  bore hole  $\varnothing$ ) by inserting the steel brush Hilti HIT-RB to the back of the hole (if needed with extension) in a twisting motion and removing it.

The brush must produce natural resistance as it enters the bore hole -- if not the brush is too small and must be replaced with the proper brush diameter.

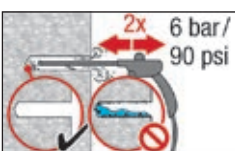

Blow again with compressed air 2 times until return air stream is free of noticeable dust.

## Setting instructions

### Injection preparation

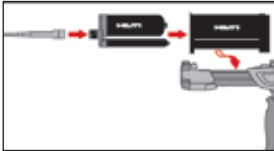

Tightly attach new Hilti mixing nozzle HIT-RE-M to foil pack manifold (snug fit). Do not modify the mixing nozzle. Observe the instruction for use of the dispenser. Check foil pack holder for proper function. Do not use damaged foil packs / holders. Swing foil pack holder with foil pack into HIT dispenser.

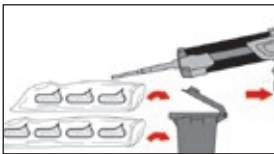

The foil pack opens automatically as dispensing is initiated. Discard initial adhesive. Depending on the size of the foil pack an initial amount of adhesive has to be discarded.

Discard quantities are:

3 strokes for 330 ml foil pack,

4 strokes for 500 ml foil pack

65 ml for 1400 ml foil pack

### Inject adhesive from the back of the borehole without forming air voids

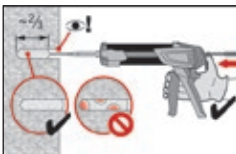

Inject the adhesive starting at the back of the hole, slowly withdrawing the mixer with each trigger pull. Fill holes approximately 2/3 full. It is required that the annular gap between the anchor and the concrete is completely filled with adhesive along the embedment length.



After injection is completed, depressurise the dispenser by pressing the release trigger. This will prevent further adhesive discharge from the mixer.

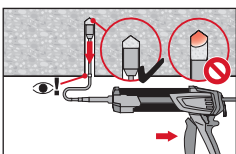

Overhead installation and/or installation with embedment depth  $h_{ef} > 250\text{mm}$ . For overhead installation the injection is only possible with the aid of extensions and piston plugs. Assemble HIT-RE-M mixer, extension(s) and appropriately sized piston plug HIT-SZ. Insert piston plug to back of the hole and inject adhesive. During injection the piston plug will be naturally extruded out of the bore hole by the adhesive pressure.  
**Under water application:** fill bore hole completely with mortar

### Setting the element

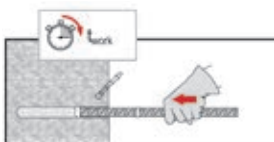

Before use, verify that the element is dry and free of oil and other contaminants.

Mark and set element to the required embedment depth until working time  $t_{work}$  has elapsed



For overhead installation use piston plugs and fix embedded parts with e.g. wedges HIT-OHW

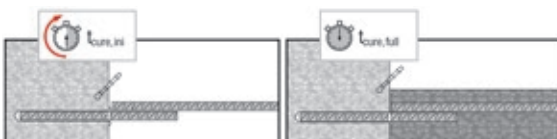

Loading the anchor:

After required curing time  $t_{cure}$  the anchor can be loaded.

## Curing time for general conditions

Data according ETA-04/0027, issue 2013-06-26		
Temperature of the base material	Working time in which anchor can be inserted and adjusted $t_{gel}$	Curing time before anchor can be fully loaded $t_{cure}$
40 °C	12 min	4 h
30 °C to 39 °C	12 min	8 h
20 °C to 29 °C	20 min	12 h
15 °C to 19 °C	30 min	24 h
10 °C to 14 °C	90 min	48 h
5 °C to 9 °C	120 min	72 h

For dry concrete curing times may be reduced according to the following table. For installation temperatures below +5 °C all load values have to be reduced according to the load reduction factors given below.

## Curing time for dry concrete



Additional Hilti technical data			
Temperature of the base material	Reduced curing time before anchor can be fully loaded $t_{cure,dry}$	Working time in which anchor can be inserted and adjusted $t_{gel}$	Load reduction factor
40 °C	4 h	12 min	1
30 °C	8 h	12 min	1
20 °C	12 h	20 min	1
15 °C	18 h	30 min	1
10 °C	24 h	90 min	1
5 °C	36 h	120 min	1
0 °C	50 h	3 h	0.7
-5 °C	72 h	4 h	0.6

## Setting details

Anchor size		Data according ETA-04/0027, issue 2013-06-26								
		Ø8	Ø10	Ø12	Ø14	Ø16	Ø20	Ø24	Ø28	Ø32
Nominal diameter of drill bit	$d_0$ [mm]	12	14	16	18	20	25	32	35	40
Effective anchorage and drill hole depth range a)	$h_{ef,min}$ [mm]	60	60	70	75	80	90	100	112	128
	$h_{ef,max}$ [mm]	160	200	240	280	320	400	500	560	640
Minimum base material thickness	$h_{min}$ [mm]	$h_{ef} + 30 \text{ mm}$ $\geq 100 \text{ mm}$			$h_{ef} + 2 d_0$					
Minimum spacing	$s_{min}$ [mm]	40	50	60	70	80	100	125	140	160
Minimum edge distance	$c_{min}$ [mm]	40	50	60	70	80	100	125	140	160

a)  $h_{ef,min} \leq h_{ef} \leq h_{ef,max}$  ( $h_{ef}$ : embedment depth)

## Hilti HIT-RE 500 with rebar in diamond drilled holes

Injection Mortar System	Benefits
 <p>Hilti HIT-RE 500 330 ml foil pack (also available as 500 ml and 1400 ml foil pack)</p>  <p>Static mixer</p>  <p>Rebar BSt 500 S</p>	<ul style="list-style-type: none"> <li>■ suitable for non-cracked concrete C 20/25 to C 50/60</li> <li>■ high loading capacity</li> <li>■ suitable for dry and water saturated concrete</li> <li>■ under water application</li> <li>■ large diameter applications</li> <li>■ high corrosion resistant</li> <li>■ long working time at elevated temperatures</li> <li>■ odourless epoxy</li> <li>■ embedment depth range: from 60 ... 160 mm for Ø8 to 128 ... 640 mm for Ø32</li> </ul>



Concrete



Small edge distance & spacing



Variable embedment depth



Diamond drilled holes



PROFIS anchor design software

### Approvals / certificates

Description	Authority / Laboratory	No. / date of issue
European technical approval a)	DIBt, Berlin	ETA-04/0027 / 2013-06-26

a) All data given in this section according ETA-04/0027, issue 2013-06-26.

### Service temperature range

Hilti HIT-RE 500 injection mortar may be applied in the temperature ranges given below. An elevated base material temperature may lead to a reduction of the design bond resistance.

Temperature range	Base material temperature	Maximum long term base material temperature	Maximum short term base material temperature
Temperature range I	-40 °C to +40 °C	+24 °C	+40 °C
Temperature range II	-40 °C to +58 °C	+35 °C	+58 °C
Temperature range III	-40 °C to +70 °C	+43 °C	+70 °C

#### Max short term base material temperature

Short-term elevated base material temperatures are those that occur over brief intervals, e.g. as a result of diurnal cycling.

#### Max long term base material temperature

Long-term elevated base material temperatures are roughly constant over significant periods of time

## Design process for typical anchor layouts

The design values in the tables are obtained from Profis V2.4.2 in compliance with the design method according to EOTA TR 029. Design resistance according to data given in ETA-04/0027, issue 2013-06-26.

- Influence of concrete strength
- Influence of edge distance
- Influence of spacing

The design method is based on the following simplification:

- No different loads are acting on individual anchors (no eccentricity)

The values are valid for the anchor configuration.

For more complex fastening applications please use the anchor design software PROFIS Anchor.

### STEP 1: TENSION LOADING

The design tensile resistance  $N_{Rd}$  is the lower of:

- Combined pull-out and concrete cone resistance

$$N_{Rd,p} = f_{B,p} \cdot N^*_{Rd,p}{}^1$$

$N^*_{Rd,p}$  is obtained from the relevant design tables

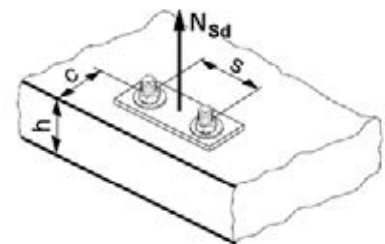

$f_{B,p}$  influence of concrete strength on combined pull-out and concrete cone resistance

Concrete Strengths $f'_{c,cyl}$ (MPa)	20	24	32	40	50
$f_{B,p}$	0.95	0.97	1.00	1.02	1.04

<sup>1</sup> Data apply for wet concrete and diamond cored holes.

For hammer drilled holes please see chapter "HIT-RE 500 with rebar in hammer drilled holes".

- Concrete cone or concrete splitting resistance

$$N_{Rd,c} = f_B \cdot N^*_{Rd,c}{}^2$$

$N^*_{Rd,c}$  is obtained from the relevant design tables

$f_B$  influence of concrete strength on concrete cone resistance

Concrete Strengths $f'_{c,cyl}$ (MPa)	20	24	32	40	50
$f_B$	0.79	0.87	1.00	1.11	1.22

<sup>2</sup> Data apply for wet concrete and diamond cored holes.

For hammer drilled holes please see chapter "HIT-RE 500 with rebar in hammer drilled holes".

- Design steel resistance  $N_{Rd,s}$

Anchor size	Ø8	Ø10	Ø12	Ø14	Ø16	Ø20	Ø24	Ø28	Ø32
$N_{Rd,s}$ BSt 500 S [kN]	20.0	30.7	44.3	60.7	79.3	123.6	177.8	242.1	315.7

$$N_{Rd} = \min \{ N_{Rd,p}, N_{Rd,c}, N_{Rd,s} \}$$

**CHECK  $N_{Rd} \geq N_{Sd}$**



## STEP 2: SHEAR LOADING

The design shear resistance  $V_{Rd}$  is the lower of:

### ■ Design Concrete Edge Resistance

$$V_{Rd,c} = f_B \cdot V^*_{Rd,c}$$

$V^*_{Rd,c}$  is obtained from the relevant design table

### $f_B$ influence of concrete strength

Concrete Strengths $f'_{c,cyl}$ (MPa)	20	24	32	40	50
$f_B$	0.79	0.87	1.00	1.11	1.22

### Shear load acting parallel to edge:

These tables are for a single free edge only

#### 2 anchors:

For shear loads acting parallel to this edge, the concrete resistance  $V^*_{Rd,c}$  can be multiplied by the factor = 2.5

#### 4 anchors:

For shear loads acting parallel to the edge - the anchor row closest to the edge is checked to resist half the total design load.

To obtain the concrete resistance use the corresponding 2 anchor configuration  $V^*_{Rd,c}$  and multiply by the factor = 2.5

### ■ Design steel resistance $V_{Rd,s}$

Anchor size	Ø8	Ø10	Ø12	Ø14	Ø16	Ø20	Ø24	Ø28	Ø32
$V_{Rd,s}$ BSt 500 S [kN]	9.3	14.7	20.7	28.0	36.7	57.3	83.0	112.7	147.3

$$V_{Rd} = \min \{ V_{Rd,c}, V_{Rd,s} \}$$

$$\text{CHECK } V_{Rd} \geq V_{Sd}$$

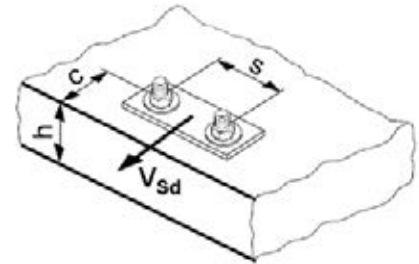

## STEP 3: COMBINED TENSION AND SHEAR LOADING

The following equations must be satisfied:

$$N_{Sd}/N_{Rd} + V_{Sd}/V_{Rd} \leq 1.2$$

and

$$N_{Sd}/N_{Rd} \leq 1, V_{Sd}/V_{Rd} \leq 1$$

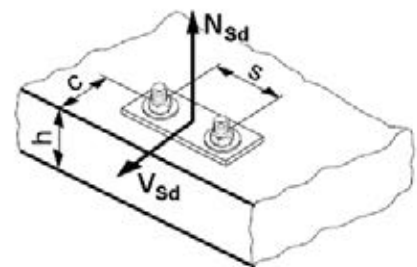



## Precalculated table values – design resistance values

### General:

The following tables provide the total ultimate limit state design resistance for the configurations. All tables are based upon:

- correct setting (See setting instruction)
- non-cracked concrete –  $f_{c,cyl} = 32 \text{ MPa}$
- temperature range I (see service temperature range)
- base material thickness, as specified in the table
- Three typical embedment depths, as specified in the tables
- wet concrete, diamond cored holes
- for hammer drilled holes please see chapter “HIT-RE 500 with rebar in hammer drilled holes”

The following tables give design values for 3 embedment depths. The latest version of the Hilti software Profis allows the engineer to optimise their design by varying the embedment depth according to the applied loads to achieve an economical solution every time. This is done by selecting rebar.

The anchor design software program Profis can be download from the Hilti Australia website, [www.hilti.com.au](http://www.hilti.com.au).

## Single anchor - no edge and spacing influences

### Embedment 1

Design Resistance $f_{c,cyl} - 32\text{Mpa}$									
Rebar size		Ø8	Ø10	Ø12	Ø16	Ø20	Ø24	Ø28	Ø32
Embedment depth	[mm]	60	60	72	96	120	144	168	192
Base material thickness	[mm]	100	100	104	136	170	210	238	272
<b>Tensile Single anchor no edge</b>									
Pull-out	$N_{Rd,p}^*$ [kN]	10.5	13.2	19.0	26.5	37.6	48.0	59.0	67.4
Concrete	$N_{Rd,c}^*$ [kN]	16.5	16.5	21.7	28.6	40.0	52.5	66.2	80.9
<b>Shear Single anchor no edge</b>									
Shear	$V_{Rd,s}$ [kN]	9.3	14.7	20.7	36.7	57.3	83.0	112.7	147.3

### Embedment 2



Design Resistance $f_{c,cyl} - 32\text{Mpa}$									
Rebar size		Ø8	Ø10	Ø12	Ø16	Ø20	Ø24	Ø28	Ø32
Embedment depth	[mm]	80	90	110	125	170	210	270	300
Base material thickness	[mm]	110	120	142	165	220	274	340	380
<b>Tensile Single anchor no edge</b>									
Pull-out	$N_{Rd,p}^*$ [kN]	14.0	19.8	29.0	34.5	53.3	70.0	94.8	105.4
Concrete	$N_{Rd,c}^*$ [kN]	25.4	30.3	40.9	42.5	67.4	92.6	135.0	158.1
<b>Shear Single anchor no edge</b>									
Shear	$V_{Rd,s}$ [kN]	9.3	14.7	20.7	36.7	57.3	83.0	112.7	147.3

### Embedment 3



Design Resistance $f_{c,cyl} - 32\text{Mpa}$									
Rebar size		Ø8	Ø10	Ø12	Ø16	Ø20	Ø24	Ø28	Ø32
Embedment depth	[mm]	96	120	144	192	240	288	336	384
Base material thickness	[mm]	126	150	176	232	290	352	406	464
<b>Tensile Single anchor no edge</b>									
Pull-out	$N_{Rd,p}^*$ [kN]	16.9	26.3	37.9	53.0	75.3	96.0	118.0	134.9
Concrete	$N_{Rd,c}^*$ [kN]	33.4	46.6	61.3	80.9	113.1	148.7	187.3	228.9
<b>Shear Single anchor no edge</b>									
Shear	$V_{Rd,s}$ [kN]	9.3	14.7	20.7	36.7	57.3	83.0	112.7	147.3

## Single anchor - minimum edge distance influence



### Embedment 1

Design Resistance $f_{c,cyl}$ - 32Mpa											
Rebar size		Ø8	Ø10	Ø12	Ø16	Ø20	Ø24	Ø28	Ø32		
Embedment depth [mm]		60	60	72	96	120	144	168	192		
Base material thickness [mm]		100	100	104	136	170	210	238	272		
Edge Dist $c = c_{min}$ [mm]		40	50	60	80	100	125	140	160		
Tensile Single anchor min edge											
	Pull-out	$N_{Rd,p}^*$	[kN]	6.3	8.9	12.8	17.9	25.4	33.1	39.8	45.5
	Concrete	$N_{Rd,c}^*$	[kN]	9.6	10.7	12.7	16.5	23.1	31.7	38.3	46.8
Shear Single anchor min edge											
	Shear (without lever arm)	$V_{Rd,c}$	[kN]	4.4	6.2	8.4	13.6	19.9	28.6	35.0	43.8

### Embedment 2

Design Resistance $f_{c,cyl}$ - 32Mpa											
Rebar size		Ø8	Ø10	Ø12	Ø16	Ø20	Ø24	Ø28	Ø32		
Embedment depth [mm]		80	90	110	125	170	210	270	300		
Base material thickness [mm]		110	120	142	165	220	274	340	380		
Edge Dist $c = c_{min}$ [mm]		40	50	60	80	100	125	140	160		
Tensile Single anchor min edge											
	Pull-out	$N_{Rd,p}^*$	[kN]	8.0	11.3	16.5	20.4	31.7	43.2	59.5	68.4
	Concrete	$N_{Rd,c}^*$	[kN]	12.1	14.7	19.6	21.5	33.1	45.6	63.8	75.3
Shear Single anchor min edge											
	Shear (without lever arm)	$V_{Rd,c}$	[kN]	4.7	6.7	9.3	14.5	21.7	31.6	40.0	49.8

### Embedment 3

Design Resistance $f_{c,cyl}$ - 32Mpa											
Rebar size		Ø8	Ø10	Ø12	Ø16	Ø20	Ø24	Ø28	Ø32		
Embedment depth [mm]		96	120	144	192	240	288	336	384		
Base material thickness [mm]		126	150	176	232	290	352	406	464		
Edge Dist $c = c_{min}$ [mm]		40	50	60	80	100	125	140	160		
Tensile Single anchor min edge											
	Pull-out	$N_{Rd,p}^*$	[kN]	9.6	15.0	21.7	30.8	44.8	59.3	74.0	87.5
	Concrete	$N_{Rd,c}^*$	[kN]	15.0	20.9	27.4	36.2	50.6	67.1	83.8	102.4
Shear Single anchor min edge											
	Shear (without lever arm)	$V_{Rd,c}$	[kN]	4.9	7.2	9.9	16.3	23.9	34.7	42.8	53.9

## 2 Anchors - min spacing influence

### Embedment 1

Design Resistance $f_{c,cyl} - 32\text{Mpa}$											
Rebar size		Ø8	Ø10	Ø12	Ø16	Ø20	Ø24	Ø28	Ø32		
Embedment depth	[mm]	60	60	72	96	120	144	168	192		
Base material thickness	[mm]	100	100	104	136	170	210	238	272		
Spacing Dist $s = s_{min}$	[mm]	40	50	60	80	100	125	140	160		
Tensile $N_{Rd}$											
	Pull-out	$N_{Rd,p}^*$	[kN]	14.2	17.8	25.0	34.5	48.8	63.3	77.7	90.1
	Concrete	$N_{Rd,c}^*$	[kN]	19.9	20.8	26.2	34.4	48.1	64.5	79.7	97.4
Shear $V_{Rd}$											
$V_{Rd,s}$ steel (per anchor)	[kN]	9.3	14.7	20.7	36.7	57.3	83	112.6	147.3		
$V_{Rd,c}$ pryout	[kN]	N/A					177.2	217.5	252.3		

### Embedment 2

Design Resistance $f_{c,cyl} - 32\text{Mpa}$											
Rebar size		Ø8	Ø10	Ø12	Ø16	Ø20	Ø24	Ø28	Ø32		
Embedment depth	[mm]	80	90	110	125	170	210	270	300		
Base material thickness	[mm]	110	120	142	165	220	270	340	380		
Spacing Dist $s = s_{min}$	[mm]	40	50	60	80	100	125	140	160		
Tensile $N_{Rd}$											
	Pull-out	$N_{Rd,p}^*$	[kN]	19.1	26.2	37.9	44.3	69.0	92.6	127.9	144.8
	Concrete	$N_{Rd,c}^*$	[kN]	28.4	34.1	45.9	48.6	76.2	104.8	150.4	176.7
Shear $V_{Rd}$											
$V_{Rd,s}$ steel (per anchor)	[kN]	9.3	14.7	20.7	36.7	57.3	83.0	112.7	147.3		

### Embedment 3

Design Resistance $f_{c,cyl} - 32\text{Mpa}$											
Rebar size		Ø8	Ø10	Ø12	Ø16	Ø20	Ø24	Ø28	Ø32		
Embedment depth	[mm]	96	120	144	192	240	288	336	384		
Base material thickness	[mm]	126	150	176	232	290	348	406	464		
Spacing Dist $s = s_{min}$	[mm]	40	50	60	80	100	125	140	160		
Tensile $N_{Rd}$											
	Pull-out	$N_{Rd,p}^*$	[kN]	23.1	35.7	50.8	70.6	100.8	130.6	161.9	188.6
	Concrete	$N_{Rd,c}^*$	[kN]	36.5	51.0	67.0	88.4	123.5	162.9	204.6	250.0
Shear $V_{Rd}$											
$V_{Rd,s}$ steel (per anchor)	[kN]	9.3	14.7	20.7	36.7	57.3	90	112.7	147.3		

## Materials

### Mechanical properties of rebar BSt 500S

Anchor size			Ø8	Ø10	Ø12	Ø14	Ø16	Ø20	Ø24	Ø28	Ø32
Nominal tensile strength $f_{uk}$	BSt 500 S	[N/mm <sup>2</sup> ]	550	550	550	550	550	550	550	550	550
Yield strength $f_{yk}$	BSt 500 S	[N/mm <sup>2</sup> ]	500	500	500	500	500	500	500	500	500
Stressed cross-section $A_s$	BSt 500 S	[mm <sup>2</sup> ]	50.3	78.5	113.1	153.9	201.1	314.2	452.0	615.8	804.2
Moment of resistance	BSt 500 S	[mm <sup>3</sup> ]	50.3	98.2	169.6	269.4	402.1	785.4	1415	2155	3217

## Material quality

Part	Material
rebar BSt 500 S	Geometry and mechanical properties according to DIN 488-2:1986 or E DIN 488-2:2006

## Setting

### installation equipment

Anchor size	Ø8	Ø10	Ø12	Ø14	Ø16	Ø20	Ø24	Ø28	Ø32	
Drilling tools	DD EC-1, DD 100 ... DD xxx									
Other tools	compressed air gun or blow out pump, set of cleaning brushes, dispenser									

## Setting instructions

### Bore hole drilling

#### Diamond coring

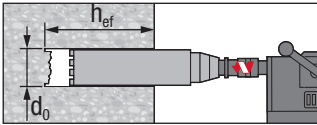

Diamond coring is permissible when diamond core drilling machine and the corresponding core bit are used.

### Bore hole cleaning

Just before setting an anchor, the bore hole must be free of dust and debris.

#### Cleaning of diamond cored holes for all bore hole diameters $d_0$ and all bore hole depth $h_0$

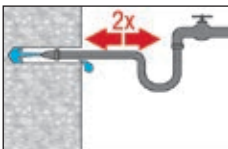

Flush 2 times the hole by inserting a water hose (water-line pressure) to the back of the hole until water runs clear.

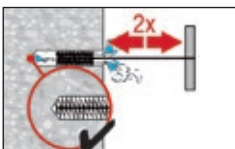

Brush 2 times with the specified brush size (brush  $\varnothing \geq$  bore hole  $\varnothing$ ) by inserting the steel brush Hilti HIT-RB to the back of the hole (if needed with extension) in a twisting motion and removing it.

The brush must produce natural resistance as it enters the bore hole -- if not the brush is too small and must be replaced with the proper brush diameter.

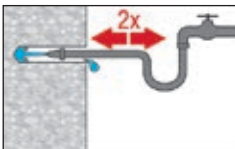

Flush 2 times the hole by inserting a water hose (water-line pressure) to the back of the hole until water runs clear.

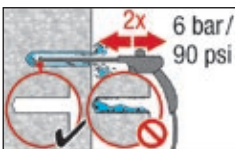

Blow 2 times from the back of the hole (if needed with nozzle extension) over the hole length with oil-free compressed air (min. 6 bar at 6 m<sup>3</sup>/h) until return air stream is free of noticeable dust and water

Bore hole diameter  $\geq$  32 mm the compressor must supply a minimum air flow of 140 m<sup>3</sup>/hour.

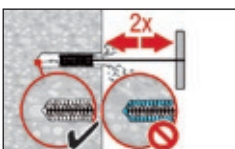

Brush 2 times with the specified brush size (brush  $\varnothing \geq$  bore hole  $\varnothing$ ) by inserting the steel brush Hilti HIT-RB to the back of the hole (if needed with extension) in a twisting motion and removing it.

The brush must produce natural resistance as it enters the bore hole -- if not the brush is too small and must be replaced with the proper brush diameter.

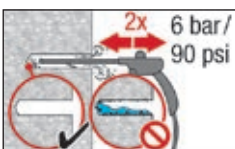

Blow again with compressed air 2 times until return air stream is free of noticeable dust.

## Setting instructions

### Injection preparation

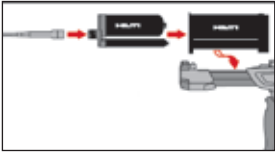

Tightly attach new Hilti mixing nozzle HIT-RE-M to foil pack manifold (snug fit). Do not modify the mixing nozzle. Observe the instruction for use of the dispenser. Check foil pack holder for proper function. Do not use damaged foil packs / holders. Swing foil pack holder with foil pack into HIT dispenser.

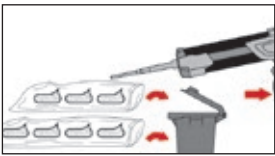

The foil pack opens automatically as dispensing is initiated. Discard initial adhesive. Depending on the size of the foil pack an initial amount of adhesive has to be discarded.

Discard quantities are:  
3 strokes for 330 ml foil pack,  
4 strokes for 500 ml foil pack  
65 ml for 1400 ml foil pack

### Inject adhesive from the back of the borehole without forming air voids

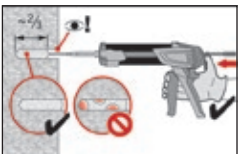

Inject the adhesive starting at the back of the hole, slowly withdrawing the mixer with each trigger pull. Fill holes approximately 2/3 full. It is required that the annular gap between the anchor and the concrete is completely filled with adhesive along the embedment length.



After injection is completed, depressurise the dispenser by pressing the release trigger. This will prevent further adhesive discharge from the mixer.

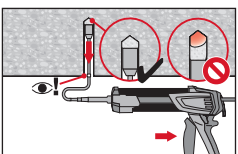

Overhead installation and/or installation with embedment depth  $h_{ef} > 250\text{mm}$ . For overhead installation the injection is only possible with the aid of extensions and piston plugs. Assemble HIT-RE-M mixer, extension(s) and appropriately sized piston plug HIT-SZ. Insert piston plug to back of the hole and inject adhesive. During injection the piston plug will be naturally extruded out of the bore hole by the adhesive pressure.  
**Under water application:** fill bore hole completely with mortar

### Setting the element

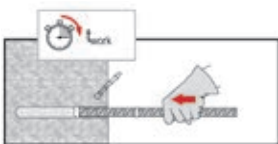

Before use, verify that the element is dry and free of oil and other contaminants.  
Mark and set element to the required embedment depth until working time  $t_{work}$  has elapsed

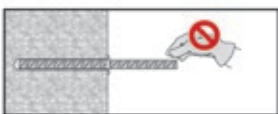

For overhead installation use piston plugs and fix embedded parts with e.g. wedges HIT-OHW

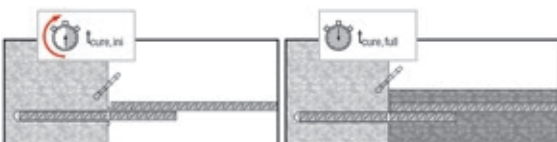

Loading the anchor:  
After required curing time  $t_{cure}$  the anchor can be loaded.

## Curing time for general conditions



Data according ETA-07/0260, issue 2013-06-26		
Temperature of the base material	Working time in which anchor can be inserted and adjusted $t_{\text{gel}}$	Curing time before anchor can be fully loaded $t_{\text{cure}}$
40 °C	12 min	4 h
30 °C to 39 °C	12 min	8 h
20 °C to 29 °C	20 min	12 h
15 °C to 19 °C	30 min	24 h
10 °C to 14 °C	90 min	48 h
5 °C to 9 °C	120 min	72 h

## Setting details

Anchor size		Data according ETA-04/0027, issue 2013-06-26								Additional Hilti technical data
		Ø8	Ø10	Ø12	Ø14	Ø16	Ø20	Ø24	Ø28	
Nominal diameter of drill bit	$d_0$ [mm]	12	14	16	18	20	25	32	35	40
Effective anchorage and drill hole depth range a)	$h_{\text{ef,min}}$ [mm]	60	60	70	75	80	90	100	112	128
	$h_{\text{ef,max}}$ [mm]	160	200	240	280	320	400	500	560	640
Minimum base material thickness	$h_{\text{min}}$ [mm]	$h_{\text{ef}} + 30 \text{ mm}$ $\geq 100 \text{ mm}$		$h_{\text{ef}} + 2 d_0$						
Minimum spacing	$s_{\text{min}}$ [mm]	40	50	60	70	80	100	125	140	160
Minimum edge distance	$c_{\text{min}}$ [mm]	40	50	60	70	80	100	125	140	160

a)  $h_{\text{ef,min}} \leq h_{\text{ef}} \leq h_{\text{ef,max}}$  ( $h_{\text{ef}}$ : embedment depth)

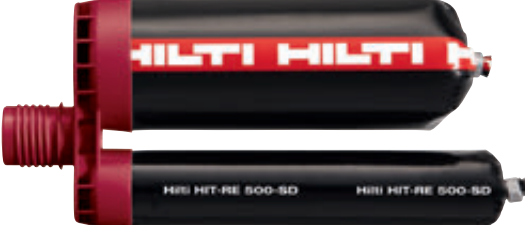
## Hilti HIT-RE 500-SD with HIT-V

Injection Mortar System	Benefits
 <p>Hilti HIT-RE 500-SD 330 ml foil pack (also available as 500 ml and 1400 ml foil pack)</p>	<ul style="list-style-type: none"> <li>■ suitable for cracked concrete C 20/25 to C 50/60</li> <li>■ high loading capacity</li> <li>■ suitable for dry and water saturated concrete</li> <li>■ large diameter applications</li> <li>■ high corrosion resistant</li> <li>■ long working time at elevated temperatures</li> <li>■ odourless epoxy</li> <li>■ embedment depth range: from 40 ... 160 mm for M8 to 120 ... 600 mm for M30</li> </ul>
 <p>Static mixer</p>	
 <p>HIT-V rods HIT-V (Zinc) HIT-V-F (Gal) HIT-V-R (A4-70) HIT-V-HCR rods</p>	



Concrete



Tensile zone



Small edge  
distance  
& spacing



Variable  
embedment  
depth



Fire  
resistance



Shock



Seismic



Corrosion  
resistance



High  
corrosion  
resistance



European  
Technical  
Approval



CE  
conformity



PROFIS  
anchor design  
software



SAFEset  
approved  
automatic  
cleaning

### Approvals / certificates

Description	Authority / Laboratory	No. / date of issue
European technical approval a)	DIBt, Berlin	ETA-07/0260 / 2013-06-26
ES report	ICC evaluation service	ESR 2322 / 2007-11-01
Fire test report	MFPA, Leipzig	GS-III/B-07-070 / 2008-01-18
Assessment report (fire)	warringtonfire	WF 166402 / 2007-10-26 & suppl. WF 172920 / 2008-05-27

a) All data given in this section according ETA-07/0260, issue 2013-06-26.

### Service temperature range

Hilti HIT-RE 500-SD injection mortar may be applied in the temperature ranges given below. An elevated base material temperature may lead to a reduction of the design bond resistance.

Temperature range	Base material temperature	Maximum long term base material temperature	Maximum short term base material temperature
Temperature range I	-40 °C to +40 °C	+24 °C	+40 °C
Temperature range II	-40 °C to +58 °C	+35 °C	+58 °C
Temperature range III	-40 °C to +70 °C	+43 °C	+70 °C

#### Max short term base material temperature

Short-term elevated base material temperatures are those that occur over brief intervals, e.g. as a result of diurnal cycling.

#### Max long term base material temperature

Long-term elevated base material temperatures are roughly constant over significant periods of time



## Design process for typical anchor layouts

The design values in the tables are obtained from Profis V2.4.2 in compliance with the design method according to EOTA TR 029. Design resistance according to data given in ETA-07/0260, issue 2013-06-26.

- Influence of concrete strength
- Influence of edge distance
- Influence of spacing

The design method is based on the following simplification:

- No different loads are acting on individual anchors (no eccentricity)

The values are valid for the anchor configuration.

For more complex fastening applications please use the anchor design software PROFIS Anchor.

### STEP 1: TENSION LOADING

The design tensile resistance  $N_{Rd}$  is the lower of:

- Combined pull-out and concrete cone resistance  
 $N_{Rd,p} = f_{B,p} \cdot N^*_{Rd,p}$ <sup>1</sup>

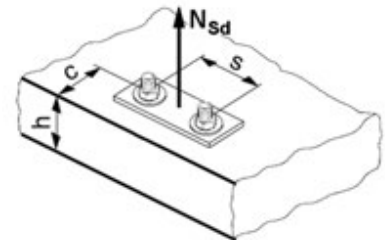

$N^*_{Rd,p}$  is obtained from the relevant design tables

$f_{B,p}$  influence of concrete strength on combined pull-out and concrete cone resistance

Concrete Strengths $f'_{c,cyl}$ (MPa)	20	25	32	40	50
$f_{B,p}$	0.95	0.97	1.00	1.021	1.04

<sup>1</sup> Data apply for dry concrete and hammer drilled holes only. For non-dry concrete multiply  $N_{rd,p}$  by the factor 0.83

- Concrete cone or concrete splitting resistance  
 $N_{Rd,c} = f_B \cdot N^*_{Rd,c}$ <sup>2</sup>

$N^*_{Rd,c}$  is obtained from the relevant design tables

$f_B$  influence of concrete strength on concrete cone resistance

Concrete Strengths $f'_{c,cyl}$ (MPa)	20	25	32	40	50
$f_B$	0.79	0.87	1.00	1.11	1.22

<sup>2</sup> For non dry concrete multiply  $N_{Rd,c}$  by the factor 0.83.

The definition of Dry Concrete, as per Hilti is: concrete not in contact with water before/during installation and curing.

- Design steel resistance (tension)  $N_{Rd,s}$

Anchor size		M8	M10	M12	M16	M20	M24	M30	
$N_{Rd,s}$	HIT-V 5.8	[kN]	12.0	19.3	28.0	52.7	82.0	118.0	187.3
	HIT-V 8.8	[kN]	19.3	30.7	44.7	84.0	130.7	188.0	299.3
	HIT-V-R	[kN]	13.9	21.9	31.6	58.8	92.0	132.1	98.3

$$N_{Rd} = \min \{ N_{Rd,p}, N_{Rd,c}, N_{Rd,s} \}$$

**CHECK  $N_{Rd} \geq N_{Sd}$**

## STEP 2: SHEAR LOADING

The design shear resistance  $V_{Rd}$  is the lower of:

### ■ Design Concrete Edge Resistance

$$V_{Rd,c} = f_B \cdot V^*_{Rd,c} \cdot \psi_{re,V}$$

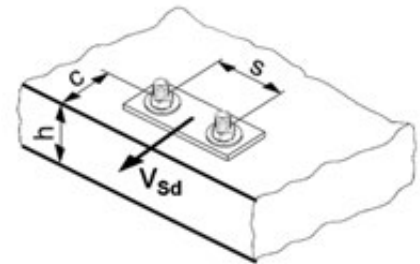

$V^*_{Rd,c}$  is obtained from the relevant design table

The factor  $\psi_{re,V}$  takes account of the effect of the type of reinforcement used in cracked concrete.

$\psi_{re,V} = 1.0$  anchorage in cracked concrete without edge reinforcement

$\psi_{re,V} = 1.2$  anchorage in cracked concrete with straight edge reinforcement ( $\geq \phi 12$  mm)

$\psi_{re,V} = 1.4$  anchorage in cracked concrete with edge reinforcement and closely spaced stirrups ( $a \leq 100$  mm)

### $f_B$ influence of concrete strength

Concrete Strengths $f'_{c,cyl}$ (MPa)	20	25	32	40	50
$f_B$	0.79	0.87	1.00	1.11	1.22

#### Shear load acting parallel to edge:

These tables are for a single free edge only

#### 2 anchors:

For shear loads acting parallel to this edge, the concrete resistance  $V^*_{Rd,c}$  can be multiplied by the factor = 2.5

#### 4 anchors:

For shear loads acting parallel to the edge - the anchor row closest to the edge is checked to resist half the total design load. To obtain the concrete resistance use the corresponding 2 anchor configuration  $V^*_{Rd,c}$  and multiply by the factor = 2.5

### ■ Design steel resistance (shear): $V_{Rd,s}$

Anchor size		M8	M10	M12	M16	M20	M24	M30	
$V_{Rd,s}$	HIT-V 5.8	[kN]	7.2	12.0	16.8	31.2	48.8	70.4	112.0
	HIT-V 8.8	[kN]	12.0	18.4	27.2	50.4	78.4	112.8	179.2
	HIT-V-R	[kN]	8.3	12.8	19.2	35.3	55.1	79.5	58.8

$$V_{Rd} = \min \{ V_{Rd,c}, V_{Rd,s} \}$$

$$\text{CHECK } V_{Rd} \geq V_{Sd}$$

## STEP 3: COMBINED TENSION AND SHEAR LOADING

The following equations must be satisfied:

$$N_{Sd}/N_{Rd} + V_{Sd}/V_{Rd} \leq 1.2$$

and

$$N_{Sd}/N_{Rd} \leq 1, V_{Sd}/V_{Rd} \leq 1$$

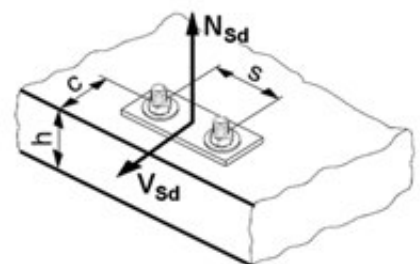

## Precalculated table values – design resistance values

### General:

The following tables provide the total ultimate limit state design resistance for the configurations. All tables are based upon:

- correct setting (See setting instruction)
- cracked concrete –  $f_{c,cyl} = 32$  MPa
- temperature range I (see service temperature range)
- base material thickness, as specified in the table
- One typical embedment depth, as specified in the tables
- dry concrete, hammer drilled hole
- for non-dry concrete multiply values by the factor 0.83

The following tables give design values for typical embedment depths. The latest version of the Hilti software Profis allows the engineer to optimise their design by varying the embedment depth according to the applied loads to achieve an economical solution every time. This is done by selecting HIT-V-Rods.

For more information on the HIT V rods please refer to the Chemical Anchor Components & Accessories section on page 240. The anchor design software program Profis can be download from the Hilti Australia website, [www.hilti.com.au](http://www.hilti.com.au).

## Basic loading data (for a single anchor) – no edge distance and spacing influence

### Embedment depth and base material thickness for the basic loading data

Anchor size	M8	M10	M12	M16	M20	M24	M30
Typical embedment depth $h_{ef}$ [mm]	80	90	110	125	170	210	270
Base material thickness $h$ [mm]	110	120	150	200	250	300	350

### Design resistance [kN]: dry cracked concrete, 32 Mpa

Anchor size		M8	M10	M12	M16	M20	M24	M30
Cracked concrete								
Tensile	Pull-out $N_{Rd,p}^*$	11.3	15.7	21.7	26.4	44.8	66.3	91.4
	Concrete $N_{Rd,c}^*$	21.7	25.9	35.0	36.4	57.7	79.2	115.4
Shear	$V_{Rd,s}$	Steel governed refer $V_{Rd,s}$ table						

## Basic loading data (for a single anchor) – with minimum edge distance

### Design resistance [kN] - dry cracked concrete, 32 Mpa

Anchor size		M8	M10	M12	M16	M20	M24
Min. edge distance $c_{min}$ [mm]		40	50	60	80	100	120
Min Base thickness $h_{min}$ [mm]		110	120	150	200	250	300
<b>Tensile <math>N_{Rd}</math></b>							
	Pull-out $N_{Rd,p}^*$	6.0	8.8	12.0	15.6	25.4	37.3
	Concrete $N_{Rd,c}^*$	10.3	12.6	17.9	21.5	32.5	43.1
<b>Shear <math>V_{Rd}</math></b>							
	Shear (without lever arm) $V_{Rd,c}$	3.3	4.8	6.6	10.3	15.4	21.1

## Two Anchors

**Table 1:** One edge influence – cracked concrete

Design Data:  $f_{c,cyl}=32$  MPa

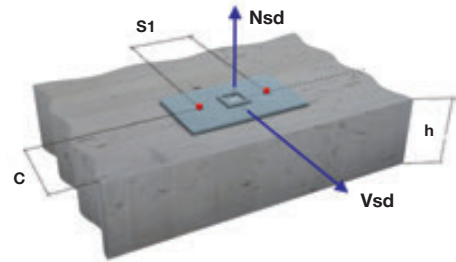
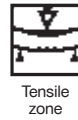

Anchor size	M8	M10	M12	M16	M20	M24
Typical embedment depth $h_{ef}$ [mm]	80	90	110	125	170	210
Base material thickness $h$ [mm]	110	120	150	200	250	300

ANCHOR <b>M8</b>	Edge E (mm)														
	40			80			100			150			170		
	tension		shear	tension		shear	tension		shear	tension		shear	tension		shear
spacing $s_1$ (mm)	$N^*_{Rd,p}$	$N^*_{Rd,c}$	$V^*_{Rd,c}$	$N^*_{Rd,p}$	$N^*_{Rd,c}$	$V^*_{Rd,c}$	$N^*_{Rd,p}$	$N^*_{Rd,c}$	$V^*_{Rd,c}$	$N^*_{Rd,p}$	$N^*_{Rd,c}$	$V^*_{Rd,c}$	$N^*_{Rd,p}$	$N^*_{Rd,c}$	$V^*_{Rd,c}$
40	8.2	11.5	4.5	11.5	15.0	9.3	13.4	16.9	10.9	15.1	22.1	14.9	15.1	24.2	16.5
80	9.0	12.7	5.6	12.7	16.6	10.6	14.9	18.7	12.2	16.7	24.4	16.1	16.7	26.9	17.7
100	9.5	13.4	6.1	13.3	17.4	11.3	15.5	19.6	12.8	17.5	25.6	16.7	17.5	28.1	18.3
120	9.8	14.0	6.7	13.9	18.1	12.0	16.2	20.4	13.5	18.2	26.6	17.3	18.2	29.4	18.9
150	10.4	14.9	6.7	14.8	19.3	13.0	17.2	21.8	14.4	19.4	28.4	18.2	19.4	31.3	19.8
200	11.4	16.4	6.7	16.2	21.4	14.6	18.8	24.0	16.1	21.2	31.3	19.8	21.2	34.4	21.2

ANCHOR <b>M10</b>	Edge C (mm)														
	50			80			100			150			200		
	tension		shear	tension		shear	tension		shear	tension		shear	tension		shear
spacing $s_1$ (mm)	$N^*_{Rd,p}$	$N^*_{Rd,c}$	$V^*_{Rd,c}$	$N^*_{Rd,p}$	$N^*_{Rd,c}$	$V^*_{Rd,c}$	$N^*_{Rd,p}$	$N^*_{Rd,c}$	$V^*_{Rd,c}$	$N^*_{Rd,p}$	$N^*_{Rd,c}$	$V^*_{Rd,c}$	$N^*_{Rd,p}$	$N^*_{Rd,c}$	$V^*_{Rd,c}$
50	11.8	14.2	6.4	14.8	16.8	10.6	16.9	18.7	12.4	21.0	23.8	16.6	21.0	29.2	20.8
100	13.1	15.7	8.0	16.4	18.7	12.5	18.8	20.8	14.1	23.5	26.4	18.5	23.5	32.5	22.3
150	14.4	17.4	9.6	18.1	20.6	14.3	20.9	22.9	15.9	25.9	29.2	19.9	25.9	35.8	24.0
200	15.7	19.0	9.6	19.8	22.4	16.2	22.8	25.0	17.7	28.3	31.8	21.6	28.3	39.0	25.5
250	17.0	20.5	9.6	21.5	24.4	17.6	24.6	27.1	19.4	30.7	34.4	23.2	30.7	42.2	27.1
300	17.5	22.1	9.6	22.1	26.3	17.6	25.3	29.2	21.2	31.6	37.1	24.9	31.6	45.6	28.7

ANCHOR <b>M12</b>	Edge C (mm)														
	60			80			100			150			200		
	tension		shear	tension		shear	tension		shear	tension		shear	tension		shear
spacing $s_1$ (mm)	$N^*_{Rd,p}$	$N^*_{Rd,c}$	$V^*_{Rd,c}$	$N^*_{Rd,p}$	$N^*_{Rd,c}$	$V^*_{Rd,c}$	$N^*_{Rd,p}$	$N^*_{Rd,c}$	$V^*_{Rd,c}$	$N^*_{Rd,p}$	$N^*_{Rd,c}$	$V^*_{Rd,c}$	$N^*_{Rd,p}$	$N^*_{Rd,c}$	$V^*_{Rd,c}$
60	15.8	20.2	8.7	18.1	22.2	11.8	20.4	24.4	15.2	26.8	30.1	20.0	28.8	36.5	24.8
100	17.2	21.6	10.2	19.4	23.9	13.4	22.0	26.2	16.9	28.8	32.4	21.6	31.1	39.1	26.3
150	18.6	23.5	12.0	21.2	25.9	15.4	23.9	28.4	19.0	31.4	35.2	23.6	33.8	42.6	28.2
200	20.2	25.4	13.1	22.9	28.1	17.4	25.9	30.7	21.1	34.0	38.0	25.5	36.6	46.1	30.0
250	21.6	27.4	13.1	24.6	30.1	18.9	27.8	33.0	23.2	36.5	40.9	27.5	39.2	49.4	31.9
300	23.2	29.2	13.1	26.3	32.2	18.9	29.6	35.3	25.3	38.9	43.7	29.4	41.9	52.8	33.8

ANCHOR <b>M16</b>	Edge C (mm)														
	80			100			150			200			250		
	tension		shear	tension		shear	tension		shear	tension		shear	tension		shear
spacing s1 (mm)	N <sup>*Rd,p</sup>	N <sup>*Rd,c</sup>	V <sup>*Rrd,c</sup>	N <sup>*Rd,p</sup>	N <sup>*Rd,c</sup>	V <sup>*Rrd,c</sup>	N <sup>*Rd,p</sup>	N <sup>*Rd,c</sup>	V <sup>*Rrd,c</sup>	N <sup>*Rd,p</sup>	N <sup>*Rd,c</sup>	V <sup>*Rrd,c</sup>	N <sup>*Rd,p</sup>	N <sup>*Rd,c</sup>	V <sup>*Rrd,c</sup>
80	20.5	26.0	13.7	22.9	29.0	17.3	29.4	37.3	25.6	34.7	44.2	31.3	34.7	44.2	36.8
100	21.2	27.2	14.6	23.8	30.4	18.2	30.4	39.0	26.6	35.9	46.1	32.2	35.9	46.1	37.7
150	23.0	30.1	16.7	25.8	33.6	20.5	33.0	43.1	29.0	39.0	50.9	34.5	39.0	50.9	39.9
200	24.8	32.9	18.9	27.8	36.7	22.8	35.6	47.2	31.4	42.1	55.8	36.8	42.1	55.8	42.1
250	26.6	35.8	20.6	29.8	40.0	25.0	38.3	51.2	33.9	45.2	60.6	39.1	45.2	60.6	44.3
300	28.4	38.6	20.6	31.8	43.2	27.3	40.8	55.1	36.3	48.2	65.4	41.4	48.2	65.4	46.6

ANCHOR <b>M20</b>	Edge C (mm)														
	120			150			200			250			300		
	tension		shear	tension		shear	tension		shear	tension		shear	tension		shear
spacing s1 (mm)	N <sup>*Rd,p</sup>	N <sup>*Rd,c</sup>	V <sup>*Rrd,c</sup>	N <sup>*Rd,p</sup>	N <sup>*Rd,c</sup>	V <sup>*Rrd,c</sup>	N <sup>*Rd,p</sup>	N <sup>*Rd,c</sup>	V <sup>*Rrd,c</sup>	N <sup>*Rd,p</sup>	N <sup>*Rd,c</sup>	V <sup>*Rrd,c</sup>	N <sup>*Rd,p</sup>	N <sup>*Rd,c</sup>	V <sup>*Rrd,c</sup>
100	32.8	37.4	20.5	40.0	44.0	31.2	48.0	51.4	39.4	56.5	59.0	45.8	57.5	67.2	52.1
150	34.9	39.8	23.1	42.7	47.0	34.0	51.2	54.7	42.2	60.5	62.9	48.5	61.4	71.6	54.7
200	37.2	42.2	25.6	45.5	49.9	36.9	54.6	58.1	45.0	64.4	66.7	51.1	65.4	76.0	57.3
250	39.5	44.8	28.2	48.2	52.8	39.7	57.8	61.3	47.8	68.3	70.6	53.8	69.4	80.4	59.9
300	41.8	47.2	30.7	51.0	55.7	42.6	61.2	64.8	50.6	72.1	74.4	56.5	73.3	84.8	62.5
350	43.9	49.7	30.7	53.8	58.6	45.4	64.4	68.0	53.4	76.1	78.2	59.2	77.3	89.2	65.1

ANCHOR <b>M24</b>	Edge C (mm)														
	120			150			200			250			350		
	tension		shear	tension		shear	tension		shear	tension		shear	tension		shear
spacing s1 (mm)	N <sup>*Rd,p</sup>	N <sup>*Rd,c</sup>	V <sup>*Rrd,c</sup>	N <sup>*Rd,p</sup>	N <sup>*Rd,c</sup>	V <sup>*Rrd,c</sup>	N <sup>*Rd,p</sup>	N <sup>*Rd,c</sup>	V <sup>*Rrd,c</sup>	N <sup>*Rd,p</sup>	N <sup>*Rd,c</sup>	V <sup>*Rrd,c</sup>	N <sup>*Rd,p</sup>	N <sup>*Rd,c</sup>	V <sup>*Rrd,c</sup>
120	46.9	49.2	28.2	46.9	49.2	35.2	60.7	60.5	47.8	70.2	68.0	55.0	83.4	84.4	69.1
150	48.5	50.8	29.9	48.5	50.8	37.0	62.8	62.3	49.8	72.6	70.1	56.9	86.3	87.0	71.0
200	51.2	53.3	32.9	51.2	53.3	40.1	66.4	65.3	53.1	76.7	73.7	60.0	91.2	91.3	73.9
250	54.0	55.8	35.8	54.0	55.8	43.2	70.0	68.5	56.4	80.9	77.2	63.2	96.1	95.6	76.8
300	56.8	58.3	38.8	56.8	58.3	46.3	73.4	71.6	59.8	85.0	80.6	66.3	100.9	100.0	79.8
350	59.5	60.8	41.7	59.5	60.8	49.4	77.0	74.8	63.1	89.0	84.1	69.5	105.8	104.4	82.7

## Four anchors

**Table 2:** One edge influence – cracked concrete

Design Data:  $f_{c,cyl}=32$  MPa

Anchor size	M8	M10	M12	M16	M20	M24
Typical embedment depth $h_{ef}$ [mm]	80	90	110	125	170	210
Base material thickness $h$ [mm]	110	120	150	200	250	300



Tensile zone

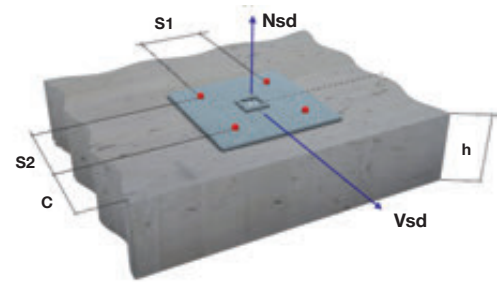

ANCHOR <b>M8</b>	Edge E (mm)														
	40			80			100			150			200		
	tension		shear	tension		shear	tension		shear	tension		shear	tension		shear
spacing $s1=s2$ (mm)	$N^*_{Rd,p}$	$N^*_{Rd,c}$	$V^*_{Rd,c}$	$N^*_{Rd,p}$	$N^*_{Rd,c}$	$V^*_{Rd,c}$	$N^*_{Rd,p}$	$N^*_{Rd,c}$	$V^*_{Rd,c}$	$N^*_{Rd,p}$	$N^*_{Rd,c}$	$V^*_{Rd,c}$	$N^*_{Rd,p}$	$N^*_{Rd,c}$	$V^*_{Rd,c}$
40	12.2	13.8	9.0	16.4	17.4	12.5	19.0	19.4	14.1	21.1	24.8	18.0	21.1	27.1	19.6
80	15.5	17.6	11.2	20.4	21.8	16.9	23.2	24.2	18.4	25.6	30.5	22.3	25.6	33.1	23.8
100	17.3	19.8	12.2	22.4	24.4	19.0	25.3	26.8	20.6	27.8	33.5	24.4	27.8	36.4	25.9
120	19.1	22.0	13.4	24.6	26.9	21.2	27.6	29.5	22.7	30.4	36.7	26.5	30.4	39.7	28.0
150	21.8	25.6	13.4	28.0	31.0	24.3	31.2	33.8	25.8	34.1	41.8	29.6	34.1	45.1	31.1
200	26.8	32.0	13.4	33.6	38.4	29.2	37.3	41.8	31.0	40.6	50.9	34.7	40.6	54.7	36.2

ANCHOR <b>M10</b>	Edge C (mm)														
	50			80			100			150			200		
	tension		shear	tension		shear	tension		shear	tension		shear	tension		shear
spacing $s1=s2$ (mm)	$N^*_{Rd,p}$	$N^*_{Rd,c}$	$V^*_{Rd,c}$	$N^*_{Rd,p}$	$N^*_{Rd,c}$	$V^*_{Rd,c}$	$N^*_{Rd,p}$	$N^*_{Rd,c}$	$V^*_{Rd,c}$	$N^*_{Rd,p}$	$N^*_{Rd,c}$	$V^*_{Rd,c}$	$N^*_{Rd,p}$	$N^*_{Rd,c}$	$V^*_{Rd,c}$
50	17.2	17.0	12.4	21.0	19.8	14.9	23.6	21.8	16.6	28.8	27.2	20.8	28.8	32.9	24.9
100	22.3	22.1	16.0	26.8	25.4	20.7	29.9	27.7	22.4	35.8	34.1	26.4	35.8	40.7	30.4
150	28.1	27.8	19.2	33.1	31.7	26.4	36.6	34.4	28.0	43.3	41.6	32.0	43.3	49.3	36.0
200	34.2	34.2	19.2	39.8	38.6	31.9	43.9	41.8	33.5	51.4	50.0	37.4	51.4	58.7	41.4
250	40.6	41.3	19.2	46.9	46.3	35.2	51.5	49.8	38.8	59.8	59.2	42.9	59.8	69.0	46.8
300	43.2	49.0	19.2	49.8	54.6	35.2	54.5	58.6	42.4	63.2	69.1	48.2	63.2	80.0	52.1

ANCHOR <b>M12</b>	Edge C (mm)														
	60			80			100			150			200		
	tension		shear	tension		shear	tension		shear	tension		shear	tension		shear
spacing $s1=s2$ (mm)	$N^*_{Rd,p}$	$N^*_{Rd,c}$	$V^*_{Rd,c}$	$N^*_{Rd,p}$	$N^*_{Rd,c}$	$V^*_{Rd,c}$	$N^*_{Rd,p}$	$N^*_{Rd,c}$	$V^*_{Rd,c}$	$N^*_{Rd,p}$	$N^*_{Rd,c}$	$V^*_{Rd,c}$	$N^*_{Rd,p}$	$N^*_{Rd,c}$	$V^*_{Rd,c}$
60	23.3	24.2	17.1	23.3	24.2	19.1	28.9	28.7	21.0	36.7	34.8	25.7	39.4	41.4	30.4
100	27.7	28.9	20.4	27.7	28.9	24.4	34.0	34.0	26.3	42.6	40.8	30.9	45.5	48.1	35.6
150	34.0	35.4	24.0	34.0	35.4	30.8	40.9	41.2	32.7	50.6	48.8	37.3	53.6	57.2	41.9
200	40.4	42.6	26.2	40.4	42.6	34.8	48.2	49.1	39.1	59.0	57.7	43.6	62.4	67.1	48.1
250	47.4	50.4	26.2	47.4	50.4	37.8	56.0	57.6	45.4	67.8	67.3	49.8	71.6	77.8	54.3
300	54.7	58.8	26.2	54.7	58.8	37.8	64.1	66.8	50.6	77.0	77.6	56.0	81.1	89.3	60.4

**Shear design:** The concrete edge resistance value in this table uses all 4 anchors in shear. You will need to ensure the gap between anchor and the plate is filled. This can be achieved using the Hilti Dynamic Set. (Refer page 41 for further details)

The concrete edge resistance values have been obtained by taking the lesser of:

1. First row resistance multiplied by number of rows and
2. The concrete edge resistance of the furthest row.

ANCHOR <b>M16</b>	Edge C (mm)														
	80			100			150			200			250		
	tension		shear	tension		shear	tension		shear	tension		shear	tension		shear
spacing s1=s2 (mm)	N*Rd,p	N*Rd,c	V*Rd,c	N*Rd,p	N*Rd,c	V*Rd,c	N*Rd,p	N*Rd,c	V*Rd,c	N*Rd,p	N*Rd,c	V*Rd,c	N*Rd,p	N*Rd,c	V*Rd,c
80	29.6	33.8	26.8	32.5	37.2	29.0	40.4	46.2	34.6	46.8	53.5	40.1	46.8	53.5	45.6
100	32.2	37.3	29.2	35.2	40.9	32.2	43.4	50.5	37.7	50.2	58.3	43.2	50.2	58.3	48.6
150	38.9	46.9	33.4	42.2	51.1	39.9	51.5	61.7	45.3	58.9	71.3	50.7	58.9	71.3	56.0
200	46.1	57.5	37.8	49.9	61.9	45.4	60.1	73.6	52.8	68.4	85.4	58.1	68.4	85.4	63.4
250	53.6	69.2	41.2	58.0	73.3	50.0	69.2	86.4	60.2	78.4	100.7	65.4	78.4	101.9	70.7
300	61.8	80.2	41.2	66.5	85.7	54.6	78.8	100.3	67.5	88.8	116.2	72.7	88.8	117.8	77.9

ANCHOR <b>M20</b>	Edge C (mm)														
	100			150			200			250			300		
	tension		shear	tension		shear	tension		shear	tension		shear	tension		shear
spacing s1=s2 (mm)	N*Rd,p	N*Rd,c	V*Rd,c	N*Rd,p	N*Rd,c	V*Rd,c	N*Rd,p	N*Rd,c	V*Rd,c	N*Rd,p	N*Rd,c	V*Rd,c	N*Rd,p	N*Rd,c	V*Rd,c
100	46.1	46.1	39.3	54.7	53.3	45.7	64.2	61.0	52.1	74.4	69.1	58.4	75.5	77.8	64.6
150	53.8	53.6	46.2	63.4	61.6	54.7	73.7	70.1	60.9	84.8	79.0	67.1	85.9	88.6	73.3
200	62.0	61.8	51.2	72.6	70.6	63.5	83.9	79.8	69.6	95.9	89.6	75.7	97.2	100.1	81.8
250	70.9	70.6	56.4	82.3	80.2	72.1	94.6	90.2	78.2	107.6	100.9	84.2	109.0	112.2	90.2
300	80.3	79.9	61.4	92.6	90.2	80.6	105.8	101.3	86.6	119.9	112.8	92.6	121.3	125.0	98.5
350	90.0	89.9	61.4	103.3	101.0	88.8	117.6	112.9	95.0	132.7	125.4	100.9	134.3	138.6	106.8

ANCHOR <b>M24</b>	Edge C (mm)														
	120			150			200			250			350		
	tension		shear	tension		shear	tension		shear	tension		shear	tension		shear
spacing s1=s2 (mm)	N*Rd,p	N*Rd,c	V*Rd,c	N*Rd,p	N*Rd,c	V*Rd,c	N*Rd,p	N*Rd,c	V*Rd,c	N*Rd,p	N*Rd,c	V*Rd,c	N*Rd,p	N*Rd,c	V*Rd,c
120	64.2	60.0	53.4	70.1	64.4	57.8	80.4	72.1	64.9	91.3	80.2	72.0	106.7	97.4	85.9
150	69.7	64.7	59.7	75.8	69.2	63.9	86.6	77.3	70.9	98.2	85.7	77.9	114.1	103.8	91.7
200	79.2	72.7	65.8	85.8	77.8	73.9	97.6	86.4	80.8	109.9	95.4	87.6	127.1	114.8	101.2
250	89.3	81.4	71.6	96.5	86.6	83.6	109.1	96.0	90.4	122.4	105.7	97.2	140.9	126.5	110.7
300	100.0	90.4	77.6	107.6	96.1	92.6	121.2	106.0	100.0	135.5	116.4	106.7	155.3	138.6	120.1
350	111.0	99.8	83.4	119.4	106.0	98.4	133.8	116.6	109.5	149.2	127.7	116.8	170.3	151.4	129.4

## Materials

### Mechanical properties of HIT-V / HAS

			Data according ETA-04/0027, issue 2008-11-03						Additional Hilti technical data	
Anchor size			M8	M10	M12	M16	M20	M24	M30	M36
Nominal tensile strength $f_{uk}$	HIT-V 5.8	[N/mm <sup>2</sup> ]	500	500	500	500	500	500	500	500
	HIT-V 8.8	[N/mm <sup>2</sup> ]	800	800	800	800	800	800	800	800
	HIT-V-R	[N/mm <sup>2</sup> ]	700	700	700	700	700	700	500	500
	HIT-V-HCR	[N/mm <sup>2</sup> ]	800	800	800	800	800	700	700	500
Yield strength $f_{yk}$	HIT-V 5.8	[N/mm <sup>2</sup> ]	400	400	400	400	400	400	400	400
	HIT-V 8.8	[N/mm <sup>2</sup> ]	640	640	640	640	640	640	640	640
	HIT-V-R	[N/mm <sup>2</sup> ]	450	450	450	450	450	450	210	210
	HIT-V/HAS -HCR	[N/mm <sup>2</sup> ]	600	600	600	600	600	400	400	250
Stressed cross-section $A_s$	HIT-V	[mm <sup>2</sup> ]	36.6	58.0	84.3	157	245	353	561	817
Section Modulus $Z$	HIT-V	[mm <sup>3</sup> ]	31.2	62.3	109	277	541	935	1874	3294
Steel failure with lever arm			M8	M10	M12	M16	M20	M24	M30	M36
Design bending moment $M_{Rd,s}$	HIT-V-5.8	[Nm]	15	30	53	134	260	449	900	1581
	HIT-V-8.8	[Nm]	24	48	84	213	415	718	1439	2530
	HIT-V-R	[Nm]	17	33	59	149	291	504	472	830
	HIT-V-HCR	[Nm]	24	48	84	213	416	449	899	1129



## Material quality

Part	Material
Threaded rod HIT-V(F)	Strength class 5.8, EN ISO 898-1, A5 > 8% ductile steel galvanized $\geq 5 \mu\text{m}$ , EN ISO 4042 (F) hot dipped galvanized $\geq 45 \mu\text{m}$ , EN ISO 10684
Threaded rod HIT-V(F)	Strength class 8.8, EN ISO 898-1, A5 > 8% ductile steel galvanized $\geq 5 \mu\text{m}$ , EN ISO 4042 (F) hot dipped galvanized $\geq 45 \mu\text{m}$ , EN ISO 10684
Threaded rod HIT-V-R	Stainless steel grade A4, A5 > 8% ductile strength class 70 for $\leq \text{M}24$ and class 50 for M27 to M30, EN ISO 3506-1, EN 10088: 1.4401
Threaded rod HIT-V-HCR	High corrosion resistant steel, EN ISO 3506-1, EN 10088: 1.4529; 1.4565 strength $\leq \text{M}20$ : $R_m = 800 \text{ N/mm}^2$ , $R_p 0.2 = 640 \text{ N/mm}^2$ , A5 > 8% ductile M24 to M30: $R_m = 700 \text{ N/mm}^2$ , $R_p 0.2 = 400 \text{ N/mm}^2$ , A5 > 8% ductile
Washer ISO 7089	Steel galvanized, EN ISO 4042; hot dipped galvanized, EN ISO 10684
	Stainless steel, EN 10088: 1.4401
	High corrosion resistant steel, EN 10088: 1.4529; 1.4565
Nut EN ISO 4032	Strength class 8, ISO 898-2 steel galvanized $\geq 5 \mu\text{m}$ , EN ISO 4042 hot dipped galvanized $\geq 45 \mu\text{m}$ , EN ISO 10684
	Strength class 70, EN ISO 3506-2, stainless steel grade A4, EN 10088: 1.4401
	Strength class 70, EN ISO 3506-2, high corrosion resistant steel, EN 10088: 1.4529; 1.4565

## Anchor dimensions

Anchor size	M8	M10	M12	M16	M20	M24	M30 <sup>a)</sup>
Anchor embedment depth [mm]	80	90	110	125	170	210	270
Anchor rod HIT-V, HIT-V-R, HIT-V-HCR	Anchor rods HIT-V (-R / -HCR) are available in variable length						

a) M30 please use anchor design software PROFIS anchor.

## Setting

### Installation equipment

Anchor size	M8	M10	M12	M16	M20	M24	M30
Rotary hammer	TE 2 - TE 30				TE 40 - TE 70		
Other tools	compressed air gun or blow out pump, set of cleaning brushes, dispenser						

## Setting instructions

### Bore hole drilling

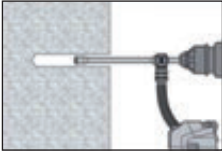

Drill hole to the required embedment depth with an appropriately sized Hilti TE-CD or TE-YD hollow drill bit with Hilti vacuum attachment. This drilling method properly cleans the borehole and removes dust while drilling. After drilling is complete, proceed to the "injection preparation" step in the instructions for use

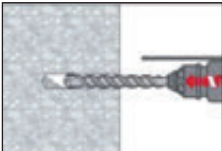

Drill Hole to the required embedment depth with a hammer drill set in rotation-hammer mode using an appropriately sized carbide drill bit.

### Bore hole cleaning Just before setting an anchor, the bore hole must be free of dust and debris.

#### b) Compressed air cleaning (CAC) for all bore hole diameters $d_0$ and all bore hole depth $h_0$



Blow 2 times from the back of the hole (if needed with nozzle extension) over the hole length with oil-free compressed air (min. 6 bar at 6 m<sup>3</sup>/h) until return air stream is free of noticeable dust. Bore hole diameter  $\geq$  32 mm the compressor must supply a minimum air flow of 140 m<sup>3</sup>/hour.

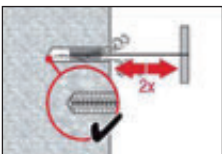

Brush 2 times with the specified brush size (brush  $\varnothing \geq$  bore hole  $\varnothing$ ) by inserting the steel brush Hilti HIT-RB to the back of the hole (if needed with extension) in a twisting motion and removing it.

The brush must produce natural resistance as it enters the bore hole -- if not the brush is too small and must be replaced with the proper brush diameter.



Blow again with compressed air 2 times until return air stream is free of noticeable dust.

### Injection preparation

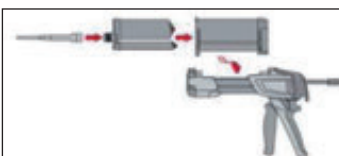

Tightly attach new Hilti mixing nozzle HIT-RE-M to foil pack manifold (snug fit). Do not modify the mixing nozzle. Observe the instruction for use of the dispenser. Check foil pack holder for proper function. Do not use damaged foil packs / holders. Swing foil pack holder with foil pack into HIT dispenser.



The foil pack opens automatically as dispensing is initiated. Discard initial adhesive. Depending on the size of the foil pack an initial amount of adhesive has to be discarded.

Discard quantities are:

3 strokes for 330 ml foil pack,

4 strokes for 500 ml foil pack

65 ml for 1400 ml foil pack

## Setting instructions

### Inject adhesive from the back of the borehole without forming air voids



Inject the adhesive starting at the back of the hole, slowly withdrawing the mixer with each trigger pull. Fill holes approximately 2/3 full. It is required that the annular gap between the anchor and the concrete is completely filled with adhesive along the embedment length.



After injection is completed, depressurise the dispenser by pressing the release trigger. This will prevent further adhesive discharge from the mixer.

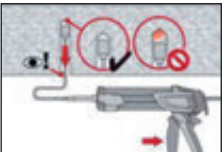

Overhead installation and/or installation with embedment depth  $h_{ef} > 250\text{mm}$ . For overhead installation the injection is only possible with the aid of extensions and piston plugs. Assemble HIT-RE-M mixer, extension(s) and appropriately sized piston plug HIT-SZ. Insert piston plug to back of the hole and inject adhesive. During injection the piston plug will be naturally extruded out of the bore hole by the adhesive pressure.

### Setting the element

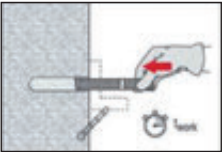

Before use, verify that the element is dry and free of oil and other contaminants.  
Mark and set element to the required embedment depth until working time  $t_{work}$  has elapsed

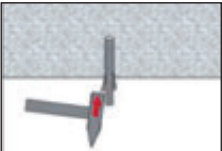

For overhead installation use piston plugs and fix embedded parts with e.g. wedges HIT-OHW

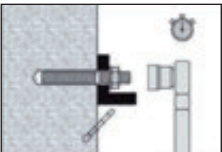

Loading the anchor:  
After required curing time  $t_{cure}$  the anchor can be loaded.  
The applied installation torque shall not exceed  $T_{max}$ .

## Curing time for general conditions

Data according ETA-07/0260, issue 2013-06-26		
Temperature of the base material	Working time in which anchor can be inserted and adjusted $t_{gel}$	Curing time before anchor can be fully loaded $t_{cure}$
40 °C	12 min	4 h
30 °C to 39 °C	12 min	8 h
20 °C to 29 °C	20 min	12 h
15 °C to 19 °C	30 min	24 h
10 °C to 14 °C	90 min	48 h
5 °C to 9 °C	120 min	72 h



## Setting details

Anchor size			Data according ETA-07/0260, issue 2013-06-26						
			M8	M10	M12	M16	M20	M24	M30
Nominal diameter of drill bit	$d_0$	[mm]	10	12	14	18	24	28	35
Effective anchorage and drill hole depth range a)	$h_{ef,min}$	[mm]	40	40	48	64	80	96	120
	$h_{ef,max}$	[mm]	160	200	240	320	400	480	600
Minimum base material thickness	$h_{min}$	[mm]	$h_{ef} + 30 \text{ mm} \geq 100 \text{ mm}$			$h_{ef} + 2 d_0$			
Diameter of clearance hole in the fixture	$d_f$	[mm]	9	12	14	18	22	26	33
Minimum spacing	$s_{min}$	[mm]	40	50	60	80	100	120	150
Minimum edge distance	$c_{min}$	[mm]	40	50	60	80	100	120	150
Torque moment b)	$T_{max}^{b)}$	[Nm]	10	20	40	80	150	200	300

a)  $h_{ef,min} \leq h_{ef} \leq h_{ef,max}$  ( $h_{ef}$ : embedment depth)

b) This is the maximum recommended torque moment to avoid splitting during installation for anchors with minimum spacing and/or edge distance.

## Hilti HIT-RE 500-SD with rebar

Injection Mortar System	Benefits
 <p>Hilti HIT-RE 500-SD 330 ml foil pack (also available as 500 ml and 1400 ml foil pack)</p>	<ul style="list-style-type: none"> <li>■ suitable for cracked concrete C 20/25 to C 50/60</li> <li>■ high loading capacity</li> <li>■ suitable for dry and water saturated concrete</li> <li>■ large diameter applications</li> <li>■ high corrosion resistant</li> <li>■ long working time at elevated temperatures</li> <li>■ odourless epoxy</li> </ul>
 <p>Static mixer</p>	
 <p>Rebar BSt 500 S</p>	



Concrete



Tensile zone



Small edge  
distance  
& spacing



Variable  
embedment  
depth



Fire  
resistance



Shock



Seismic



Corrosion  
resistance



High  
corrosion  
resistance



European  
Technical  
Approval



CE  
conformity



PROFIS  
anchor design  
software



SAFEset  
approved  
automatic  
cleaning

### Approvals / certificates

Description	Authority / Laboratory	No. / date of issue
European technical approval a)	DIBt, Berlin	ETA-07/0260 / 2013-06-26
ES report	ICC evaluation service	ESR 2322 / 2007-11-01
Fire test report	MFPA, Leipzig	GS-III/B-07-070 / 2008-01-18
Assessment report (fire)	warringtonfire	WF 166402 / 2007-10-26 & suppl. WF 172920 / 2008-05-27

a) All data given in this section according ETA-07/0260, issue 2013-06-26.

### Service temperature range

Hilti HIT-RE 500-SD injection mortar may be applied in the temperature ranges given below. An elevated base material temperature may lead to a reduction of the design bond resistance.

Temperature range	Base material temperature	Maximum long term base material temperature	Maximum short term base material temperature
Temperature range I	-40 °C to +40 °C	+24 °C	+40 °C
Temperature range II	-40 °C to +58 °C	+35 °C	+58 °C
Temperature range III	-40 °C to +70 °C	+43 °C	+70 °C

#### Max short term base material temperature

Short-term elevated base material temperatures are those that occur over brief intervals, e.g. as a result of diurnal cycling.

#### Max long term base material temperature

Long-term elevated base material temperatures are roughly constant over significant periods of time

## Design process for typical anchor layouts

The design values in the tables are obtained from Profis V2.4.2 in compliance with the design method according to EOTA TR 029. Design resistance according to data given in ETA-07/0260, issue 2013-06-26.

- Influence of concrete strength
- Influence of edge distance
- Influence of spacing

The design method is based on the following simplification:

- No different loads are acting on individual anchors (no eccentricity)

The values are valid for the anchor configuration.

For more complex fastening applications please use the anchor design software PROFIS Anchor.

### STEP 1: TENSION LOADING

The design tensile resistance  $N_{Rd}$  is the lower of:

- Combined pull-out and concrete cone resistance

$$N_{Rd,p} = f_{B,p} \cdot N^*_{Rd,p}$$

$N^*_{Rd,p}$  is obtained from the relevant design tables

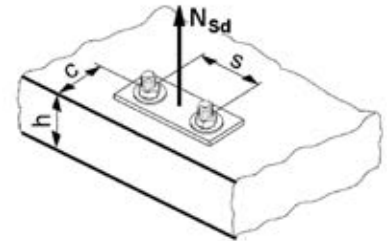

$f_{B,p}$  influence of concrete strength on combined pull-out and concrete cone resistance

Concrete Strengths $f'_{c,cyl}$ (MPa)	20	25	32	40	50
$f_{B,p}$	0.95	0.97	1.00	1.02	1.04

- Concrete cone or concrete splitting resistance

$$N_{Rd,c} = f_B \cdot N^*_{Rd,c}$$

$N^*_{Rd,c}$  is obtained from the relevant design tables

$f_B$  influence of concrete strength on concrete cone resistance

Concrete Strengths $f'_{c,cyl}$ (MPa)	20	25	32	40	50
$f_B$	0.79	0.87	1.00	1.11	1.22

- Design steel resistance  $N_{Rd,s}$

Anchor size			Ø8	Ø10	Ø12	Ø14	Ø16	Ø20	Ø24	Ø28	Ø32
$N_{Rd,s}$	BSt 500 S	[kN]	20.0	30.7	44.3	60.7	79.3	123.6	177.8	242.1	315.7

$$N_{Rd} = \min \{ N_{Rd,p}, N_{Rd,c}, N_{Rd,s} \}$$

$$\text{CHECK } N_{Rd} \geq N_{Sd}$$

## STEP 2: SHEAR LOADING

The design shear resistance  $V_{Rd}$  is the lower of:

### ■ Design Concrete Edge Resistance

$$V_{Rd,c} = f_B \cdot V^*_{Rd,c} \cdot \psi_{re,V}$$

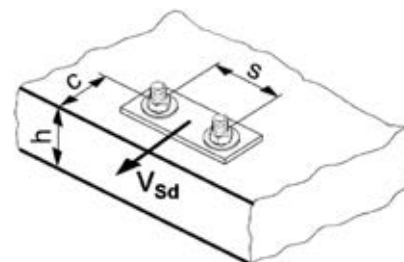

$V^*_{Rd,c}$  is obtained from the relevant design table

The factor  $\psi_{re,V}$  takes account of the effect of the type of reinforcement used in cracked concrete.

$\psi_{re,V} = 1.0$  anchorage in cracked concrete without edge reinforcement

$\psi_{re,V} = 1.2$  anchorage in cracked concrete with straight edge reinforcement ( $\geq \varnothing 12$  mm)

$\psi_{re,V} = 1.4$  anchorage in cracked concrete with edge reinforcement and closely spaced stirrups ( $a \leq 100$  mm)

### $f_B$ influence of concrete strength

Concrete Strengths $f'_{c,cyl}$ (MPa)	20	25	32	40	50
$f_B$	0.79	0.87	1.00	1.11	1.22

#### Shear load acting parallel to edge:

These tables are for a single free edge only

#### 2 anchors:

For shear loads acting parallel to this edge, the concrete resistance  $V^*_{Rd,c}$  can be multiplied by the factor = 2.5

#### 4 anchors:

For shear loads acting parallel to the edge - the anchor row closest to the edge is checked to resist half the total design load. To obtain the concrete resistance use the corresponding 2 anchor configuration  $V^*_{Rd,c}$  and multiply by the factor = 2.5

### ■ Design steel resistance $V_{Rd,s}$

Anchor size	$\varnothing 8$	$\varnothing 10$	$\varnothing 12$	$\varnothing 14$	$\varnothing 16$	$\varnothing 20$	$\varnothing 24$	$\varnothing 28$	$\varnothing 32$
$V_{Rd,s}$ BSt 500 S [kN]	9.3	14.7	20.7	28.0	36.7	57.3	83.0	112.7	147.3

$$V_{Rd} = \min \{ V_{Rd,c}, V_{Rd,s} \}$$

**CHECK  $V_{Rd} \geq V_{Sd}$**

## STEP 3: COMBINED TENSION AND SHEAR LOADING

The following equations must be satisfied:

$$N_{Sd}/N_{Rd} + V_{Sd}/V_{Rd} \leq 1.2$$

and

$$N_{Sd}/N_{Rd} \leq 1, V_{Sd}/V_{Rd} \leq 1$$

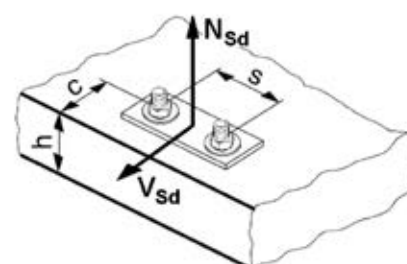

## Precalculated table values – design resistance values

### General:

The following tables provide the total ultimate limit state design resistance for the configurations.

All tables are based upon:

- correct setting (See setting instruction)
- cracked concrete –  $f_{c,cyl} = 32 \text{ MPa}$
- temperature range I (see service temperature range)
- base material thickness, as specified in the table
- Three typical embedment depths, as specified in the tables
- dry concrete, hammer drilled hole

The following tables give design values for typical embedment depths. The latest version of the Hilti software Profis allows the engineer to optimise their design by varying the embedment depth according to the applied loads to achieve an economical solution every time. This is done by selecting rebar.

The anchor design software program Profis can be download from the Hilti Australia website, [www.hilti.com.au](http://www.hilti.com.au).

## Single anchor - no edge and spacing influences



Tensile zone

### Embedment 1

Design Resistance $f_{c,cyl} - 32\text{Mpa}$									
Rebar size		Ø8	Ø10	Ø12	Ø16	Ø20	Ø24	Ø28	Ø32
Embedment depth		60	60	72	96	120	144	168	192
Base material thickness		100	100	104	136	170	210	238	272
<b>Tensile Single anchor no edge</b>									
Pull-out	$N_{Rd,p}^*$	10.5	13.2	19.0	26.5	37.6	48.0	59.0	67.4
Concrete	$N_{Rd,c}^*$	16.5	16.5	21.7	28.6	40.0	52.5	66.2	80.9
<b>Shear Single anchor no edge</b>									
Shear	$V_{Rd,s}$	9.3	14.7	20.7	36.7	57.3	83.0	112.7	147.3

### Embedment 2

Design Resistance $f_{c,cyl} - 32\text{Mpa}$									
Rebar size		Ø8	Ø10	Ø12	Ø16	Ø20	Ø24	Ø28	Ø32
Embedment depth		80	90	110	125	170	210	270	300
Base material thickness		110	120	142	165	220	274	340	380
<b>Tensile Single anchor no edge</b>									
Pull-out	$N_{Rd,p}^*$	9.4	13.1	18.1	22.0	37.3	57.6	77.0	90.3
Concrete	$N_{Rd,c}^*$	18.1	21.6	29.2	30.3	48.1	66.0	96.2	112.6
<b>Shear Single anchor no edge</b>									
Shear	$V_{Rd,s}$	9.3	14.7	20.7	36.7	57.3	83.0	112.7	147.3

### Embedment 3

Design Resistance $f_{c,cyl} - 32\text{Mpa}$									
Rebar size		Ø8	Ø10	Ø12	Ø16	Ø20	Ø24	Ø28	Ø32
Embedment depth		96	120	144	192	240	288	336	384
Base material thickness		126	150	176	232	290	352	406	464
<b>Tensile Single anchor no edge</b>									
Pull-out	$N_{Rd,p}^*$	11.2	17.5	23.7	33.7	52.7	79.0	95.9	115.6
Concrete	$N_{Rd,c}^*$	23.8	33.2	43.7	57.7	80.6	106.0	133.5	163.2
<b>Shear Single anchor no edge</b>									
Shear	$V_{Rd,s}$	9.3	14.7	20.7	36.7	57.3	83.0	112.7	147.3



## Single anchor - minimum edge distance



Tensile zone

### Embedment 1

Design Resistance $f_{c,cyl} - 32\text{Mpa}$										
Rebar size		Ø8	Ø10	Ø12	Ø16	Ø20	Ø24	Ø28	Ø32	
Embedment depth		60	60	72	96	120	144	168	192	
Base material thickness		100	100	104	136	170	210	238	272	
Edge Dist $c = c_{min}$		40	50	60	80	100	120	140	160	
Tensile Single anchor min edge										
	Pull-out	$N_{Rd,p}^*$	4.2	5.9	8.0	11.4	17.8	27.2	32.5	39.0
	Concrete	$N_{Rd,c}^*$	6.9	7.7	9.0	11.8	16.5	22.6	27.3	33.3
Shear Single anchor min edge										
	Shear (without lever arm)	$V_{Rd,c}^*$	3.1	4.4	6.0	9.7	14.1	20.3	24.8	31.0

### Embedment 2

Design Resistance $f_{c,cyl} - 32\text{Mpa}$										
Rebar size		Ø8	Ø10	Ø12	Ø16	Ø20	Ø24	Ø28	Ø32	
Embedment depth		80	90	110	125	170	210	270	300	
Base material thickness		110	120	142	165	220	270	340	380	
Edge Dist $c = c_{min}$		40	50	60	80	100	125	140	160	
Tensile Single anchor min edge										
	Pull-out	$N_{Rd,p}^*$	5.1	7.3	10.0	13.0	21.2	33.0	43.3	50.7
	Concrete	$N_{Rd,c}^*$	8.6	10.5	14.0	15.3	23.6	32.5	45.5	53.7
Shear Single anchor min edge										
	Shear (without lever arm)	$V_{Rd,c}^*$	3.3	4.8	6.6	10.3	15.4	22.4	28.3	35.3

### Embedment 3

Design Resistance $f_{c,cyl} - 32\text{Mpa}$										
Rebar size		Ø8	Ø10	Ø12	Ø16	Ø20	Ø24	Ø28	Ø32	
Embedment depth		96	120	144	192	240	288	336	384	
Base material thickness		126	150	176	232	290	348	406	464	
Edge Dist $c = c_{min}$		40	50	60	80	100	125	140	160	
Tensile Single anchor min edge										
	Pull-out	$N_{Rd,p}^*$	6.1	9.6	12.9	18.6	29.1	44.4	53.8	64.9
	Concrete	$N_{Rd,c}^*$	10.7	14.9	19.6	25.8	36.1	47.9	59.7	73.0
Shear Single anchor min edge										
	Shear (without lever arm)	$V_{Rd,c}^*$	3.5	5.1	7.0	11.5	17.0	24.6	30.3	38.2

## 2 anchors - minimum spacing influence



Tensile zone

### Embedment 1

Design Resistance $f_{c,cyl} - 32\text{Mpa}$									
Rebar size		Ø8	Ø10	Ø12	Ø16	Ø20	Ø24	Ø28	Ø32
Embedment depth		60	60	72	96	120	144	168	192
Base material thickness		100	100	104	136	170	210	238	272
Spacing dist $s=s_{min}$		40	50	60	80	100	120	140	160
Tensile $N_{Rd}$									
	Pull-out $N_{Rd,p}^*$	9.6	12.0	16.1	22.6	34.4	50.9	61.3	73.9
	Concrete $N_{Rd,c}^*$	7.8	14.8	18.7	24.5	34.3	46.0	56.8	69.4
Shear $V_{Rd}$									
$V_{Rd,s}$ steel (per anchor)		9.3	14.7	20.7	36.7	57.3	83.0	112.7	147.3
$V_{Rd,c}^*$ pryout		N/A	28.8	38.7	63.3	96.4	135.2	168.9	206.4

### Embedment 2

Design Resistance $f_{c,cyl} - 32\text{Mpa}$									
Rebar size		Ø8	Ø10	Ø12	Ø16	Ø20	Ø24	Ø28	Ø32
Embedment depth		80	90	110	125	170	210	270	300
Base material thickness		110	120	142	165	220	270	340	380
Spacing dist $s=s_{min}$		40	50	60	80	100	125	140	160
Tensile $N_{Rd}$									
	Pull-out $N_{Rd,p}^*$	12.7	17.5	24.1	28.9	47.9	72.0	97.8	114.7
	Concrete $N_{Rd,c}^*$	20.2	24.3	32.7	34.7	54.3	74.7	107.2	126.0
Shear $V_{Rd}$									
$V_{Rd,s}$ steel (per anchor)		9.3	14.7	20.7	36.7	57.3	83.0	112.7	147.3
$V_{Rd,c}^*$ pryout			N/A		81.0	134.2	201.7	273.9	321.0

### Embedment 3

Design Resistance $f_{c,cyl} - 32\text{Mpa}$									
Rebar size		Ø8	Ø10	Ø12	Ø16	Ø20	Ø24	Ø28	Ø32
Embedment depth		96	120	144	192	240	288	336	384
Base material thickness		126	150	176	232	290	348	406	464
Spacing dist $s=s_{min}$		40	50	60	80	100	125	140	160
Tensile $N_{Rd}$									
	Pull-out $N_{Rd,p}^*$	15.4	23.7	31.9	45.1	69.3	101.9	124.8	150.6
	Concrete $N_{Rd,c}^*$	26.0	36.2	47.7	63.0	88.1	116.2	145.9	178.2
Shear $V_{Rd}$									
$V_{Rd,s}$ (per anchor)		9.3	14.7	20.7	36.7	57.3	83.0	112.7	147.3

## Materials

### Mechanical properties of rebar BSt 500S

Anchor size			Ø8	Ø10	Ø12	Ø14	Ø16	Ø20	Ø24	Ø28	Ø32
Nominal tensile strength $f_{uk}$	BSt 500 S	[N/mm <sup>2</sup> ]	550	550	550	550	550	550	550	550	550
Yield strength $f_{yk}$	BSt 500 S	[N/mm <sup>2</sup> ]	500	500	500	500	500	500	500	500	500
Stressed cross-section $A_s$	BSt 500 S	[mm <sup>2</sup> ]	50.3	78.5	113.1	153.9	201.1	314.2	452	615.8	804.2
Moment of resistance	BSt 500 S	[mm <sup>3</sup> ]	50.3	98.2	169.6	269.4	402.1	785.4	1415	2155	3217

## Material quality

Part	Material
rebar BSt 500 S	Geometry and mechanical properties according to DIN 488-2:1986 or E DIN 488-2:2006

## Setting

### installation equipment

Anchor size	Ø8	Ø10	Ø12	Ø14	Ø16	Ø20	Ø24	Ø28	Ø32	
Rotary hammer	TE 2 - TE 16					TE 40- TE 70				
Other tools	compressed air gun or blow out pump, set of cleaning brushes, dispenser									

## Setting instructions

### Bore hole drilling

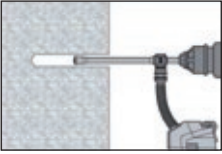

Drill hole to the required embedment depth with an appropriately sized Hilti TE-CD or TE-YD hollow drill bit with Hilti vacuum attachment. This drilling method properly cleans the borehole and removes dust while drilling. After drilling is complete, proceed to the "injection preparation" step in the instructions for use

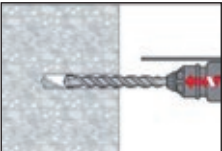

Drill Hole to the required embedment depth with a hammer drill set in rotation-hammer mode using an appropriately sized carbide drill bit.

### Bore hole cleaning **Just before setting an anchor, the bore hole must be free of dust and debris.**

#### a) Manual Cleaning (MC) non-cracked concrete only for bore hole diameters $d_0 \leq 20\text{mm}$ and bore hole depth $h_0 \leq 10d$

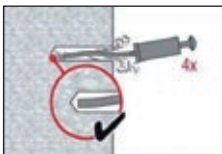

The Hilti manual pump may be used for blowing out bore holes up to diameters  $d_0 \leq 20\text{ mm}$  and embedment depths up to  $h_{ef} \leq 10d$ . Blow out at least 4 times from the back of the bore hole until return air stream is free of noticeable dust

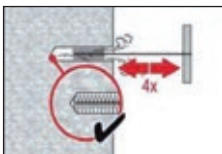

Brush 4 times with the specified brush size by inserting the steel brush Hilti HIT-RB to the back of the hole (if needed with extension) in a twisting motion and removing it. The brush must produce natural resistance as it enters the bore hole -- if not the brush is too small and must be replaced with the proper brush diameter.

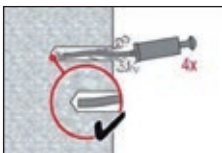

Blow out again with manual pump at least 4 times until return air stream is free of noticeable dust.

#### b) Compressed air cleaning (CAC) for all bore hole diameters $d_0$ and all bore hole depth $h_0$



Blow 2 times from the back of the hole (if needed with nozzle extension) over the hole length with oil-free compressed air (min. 6 bar at  $6\text{ m}^3/\text{h}$ ) until return air stream is free of noticeable dust. Bore hole diameter  $\geq 32\text{ mm}$  the compressor must supply a minimum air flow of  $140\text{ m}^3/\text{hour}$ .

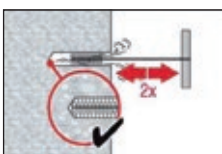

Brush 2 times with the specified brush size (brush  $\varnothing \geq$  bore hole  $\varnothing$ ) by inserting the steel brush Hilti HIT-RB to the back of the hole (if needed with extension) in a twisting motion and removing it. The brush must produce natural resistance as it enters the bore hole -- if not the brush is too small and must be replaced with the proper brush diameter.



Blow again with compressed air 2 times until return air stream is free of noticeable dust.

## Setting instructions

### Injection preparation

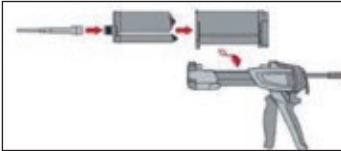

Tightly attach new Hilti mixing nozzle HIT-RE-M to foil pack manifold (snug fit). Do not modify the mixing nozzle. Observe the instruction for use of the dispenser. Check foil pack holder for proper function. Do not use damaged foil packs / holders. Swing foil pack holder with foil pack into HIT dispenser.

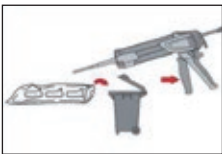

The foil pack opens automatically as dispensing is initiated. Discard initial adhesive. Depending on the size of the foil pack an initial amount of adhesive has to be discarded.

Discard quantities are:  
3 strokes for 330 ml foil pack,  
4 strokes for 500 ml foil pack  
65 ml for 1400 ml foil pack

### Inject adhesive from the back of the borehole without forming air voids



Inject the adhesive starting at the back of the hole, slowly withdrawing the mixer with each trigger pull. Fill holes approximately 2/3 full. It is required that the annular gap between the anchor and the concrete is completely filled with adhesive along the embedment length.



After injection is completed, depressurise the dispenser by pressing the release trigger. This will prevent further adhesive discharge from the mixer.

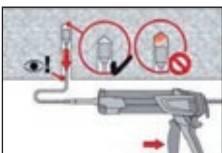

Overhead installation and/or installation with embedment depth  $h_{ef} > 250\text{mm}$ . For overhead installation the injection is only possible with the aid of extensions and piston plugs. Assemble HIT-RE-M mixer, extension(s) and appropriately sized piston plug HIT-SZ. Insert piston plug to back of the hole and inject adhesive. During injection the piston plug will be naturally extruded out of the bore hole by the adhesive pressure.

### Setting the element

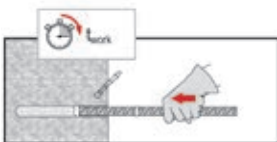

Before use, verify that the element is dry and free of oil and other contaminants.  
Mark and set element to the required embedment depth until working time  $t_{work}$  has elapsed



For overhead installation use piston plugs and fix embedded parts with e.g. wedges HIT-OHW

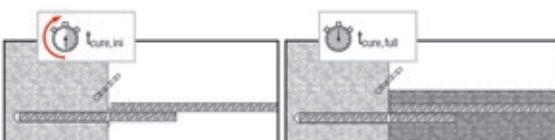

Loading the anchor:  
After required curing time  $t_{cure}$  the anchor can be loaded.

## Curing time for general conditions

Data according ETA-07/0260, issue 2013-06-26		
Temperature of the base material	Working time in which anchor can be inserted and adjusted $t_{\text{gel}}$	Curing time before anchor can be fully loaded $t_{\text{cure}}$
40 °C	12 min	4 h
30 °C to 39 °C	12 min	8 h
20 °C to 29 °C	20 min	12 h
15 °C to 19 °C	30 min	24 h
10 °C to 14 °C	90 min	48 h
5 °C to 9 °C	120 min	72 h

## Setting details

Anchor size		Data according ETA-07/0260, issue 2013-06-26								
		Ø8	Ø10	Ø12	Ø14	Ø16	Ø20	Ø24	Ø28	Ø32
Nominal diameter of drill bit	$d_0$ [mm]	12	14	16	18	20	25	32	35	40
Effective anchorage and drill hole depth range a)	$h_{\text{ef,min}}$ [mm]	60	60	70	75	80	90	100	112	128
	$h_{\text{ef,max}}$ [mm]	160	200	240	280	320	400	500	560	640
Minimum base material thickness	$h_{\text{min}}$ [mm]	$h_{\text{ef}} + 30 \text{ mm}$ $\geq 100 \text{ mm}$			$h_{\text{ef}} + 2 d_0$					
Minimum spacing	$s_{\text{min}}$ [mm]	40	50	60	70	80	100	125	140	160
Minimum edge distance	$c_{\text{min}}$ [mm]	40	50	60	70	80	100	125	140	160

a)  $h_{\text{ef,min}} \leq h_{\text{ef}} \leq h_{\text{ef,max}}$  (hef: embedment depth)

## Hilti HIT-HY 70 injection mortar for masonry

Injection Mortar System	Benefits
 <p>Hilti HIT-HY 70 330 ml foil pack (also available as 500 ml and 1400 ml foil pack)</p>	<ul style="list-style-type: none"> <li>■ chemical injection fastening for all type of base materials:                             <ul style="list-style-type: none"> <li>- hollow and solid</li> <li>- clay bricks, sand-lime bricks, normal and light weight concrete blocks, aerated light weight concrete, natural stones</li> </ul> </li> </ul>
 <p>Mixer</p>	<ul style="list-style-type: none"> <li>■ two-component hybrid mortar</li> <li>■ rapid curing</li> </ul>
 <p>HIT-V (Zinc) HIT-V-F (Gal) HIT-V-R (A4-70)</p>	<ul style="list-style-type: none"> <li>■ versatile and convenient handling</li> <li>■ flexible setting depth and fastening thickness</li> </ul>
 <p>HAS-E (Zinc) HAS-E-F (Gal) HAS-E-R (A4-70)</p>	<ul style="list-style-type: none"> <li>■ small edge distance and anchor spacing</li> <li>■ mortar filling control with HIT-SC sleeves</li> </ul>
 <p>HIT-AC, HIT-ACR rod</p>	<ul style="list-style-type: none"> <li>■ suitable for overhead fastenings</li> <li>■ in-service temperatures: short time: max. 120°C long term: max 72°C</li> </ul>
 <p>HIT-IC internal threaded sleeve</p>	
 <p>HIS-RN sleeve</p>	
 <p>HIT-SC composite sleeve</p>	

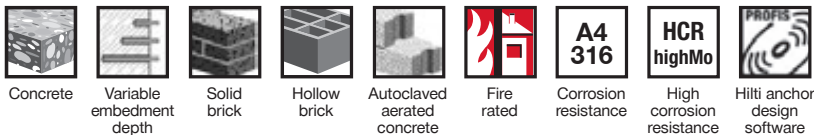

### Approvals / certificates

Description	Authority / Laboratory	No. / date of issue
Allgemeine bauaufsichtliche Zulassung (national German approval)	DIBt, Berlin	Z-21.3-1830 / 2009-01-20
Fiche technique SOCOTEC	SOCOTEC, Paris	YX 0047 08.2006
Fire test report	MFPA, Leipzig	PB III/B-07-157 / 2007-06-04
Assessment report (fire)	warringtonfire	WF 166402 / 2007-10-26



## Basic loading data for single anchor in masonry units

All data in this section applies to

- Load values valid for holes drilled with TE rotary hammers in hammering mode
- Correct anchor setting (see instruction for use, setting details)
- Steel quality of fastening elements: see data below
- Steel quality for screws for HIT-IG, HIT-IC and HIS-N: min. grade 5.8 / HIS-RN: A4-70
- Threaded rods of appropriate size (diameter and length) and a minimum steel quality of 5.8 can be used
- Base material temperature during installation and curing must be between -5°C through +40°C

## Recommended loads <sup>a)</sup> $F_{rec}$ for brick breakout and pull out in [kN]

Hollow masonry: HIT-HY 70 with HIT-SC and HIT-AC / HIT-V, HAS, HAS-E and HIT-IG / HIT-IC

Anchor size			HIT-AC, HIT-V, HAS, HAS-E					HIT-IG / HIT-IC					
			M6	M8	M10	M12		M8	M10		M12		
Base material	Setting depth [mm]		HIT-SC	HIT-SC	HIT-SC	HIT-SC	HIT-SC	HIT-SC	HIT-SC	HIT-SC	HIT-SC		
			12x...	16x...	16x...	18x...	22x...	16x...	18x... <sup>c)</sup>	22x...	22x...		
<b>Fire light brick Scoria Blend</b> $f_{uc}^{b)} \geq 4 \text{ N/mm}^2$ L x H x B [mm] 230 x 110 x 119  (Shell thickness 19 mm) Australia	50	$N_{rec}$ [kN]	0.5	0.5	0.5	0.8	0.8	-	-	-	-		
		$V_{rec}$ [kN]	1.0	1.5	1.5	1.5	2.0	-	-	-	-		
	$V_{rec}$ [kN]	Towards free edge $c_{min} = 200$	$N_{rec}$ [kN]	1.8	1.8	1.8	1.8	1.8	1.8	1.8	1.8	1.8	
			No free edges	Towards free edge $c_{min} = 200$	1.25	2.0	2.0	2.0	2.0	2.0	2.0	2.0	2.0
				No free edges	1.25	2.5	2.8	3.0	3.0	2.5	2.8	2.8	3.0
<b>Hollow Block</b> $f_{uc}^{b)} \geq 10 \text{ N/mm}^2$ L x H x B [mm] 390 x 190 x 190  (Shell thickness 30 mm) Australia	50	$N_{rec}$ [kN]	0.6	0.6	0.6	0.6	0.6	-	-	-	-		
		$V_{rec}$ [kN]	1.0	1.5	1.5	1.5	2.0	-	-	-	-		
	$V_{rec}$ [kN]	Towards free edge $c_{min} = 200$	$N_{rec}$ [kN]	0.6	0.9	0.9	1.7	1.7	0.9	1.7	1.7	1.7	
			No free edges	Towards free edge $c_{min} = 200$	1.25	2.0	2.0	2.0	2.0	2.0	2.0	2.0	2.0
				No free edges	1.25	2.5	2.8	3.0	3.0	2.5	2.8	2.8	3.0
<b>Clay common (Standard)</b> $f_{uc}^{b)} \geq 20 \text{ N/mm}^2$ L x H x B [mm] 230 x 110 x 76  (Shell thickness 20 mm) Australia	50	$N_{rec}$ [kN]	1.5	1.5	1.5	1.5	1.5	-	-	-	-		
		$V_{rec}$ [kN]	2.0	2.0	2.0	2.0	2.0	-	-	-	-		
	$V_{rec}$ [kN]	Towards free edge $c_{min} = 200$	$N_{rec}$ [kN]	2.0	3.0	3.0	3.0	4.0	3.0	4.0	4.0	4.0	
			No free edges	Towards free edge $c_{min} = 200$	2.0	2.0	2.0	2.0	2.0	2.0	2.0	2.0	2.0
				No free edges	2.0	3.5	5.5	7.5	7.5	3.5	5.5	5.5	7.5

a) Recommended load values with consideration of a global safety factor  $\gamma_{global} = 3.0$ :  $F_{rec} = F_{Rk} / \gamma_{global}$

b)  $f_{uc}$  = unconfined compressive strength

c) HIT-SC 18x ... with HIT-IC M10 only! HIT-IG M10 elements do not fit.



## Recommended loads <sup>a)</sup> $F_{rec}$ for brick breakout and pull out in [kN]

Solid masonry: HIT-HY 70 with HIT-AC / HIT-V, HAS, HAS-E and HIT-IG / HIT-IC

Anchor size			HIT-AC, HIT-V, HAS, HAS-E				HIT-IG / HIT-IC		
Base material	Setting depth [mm]		M6	M8	M10	M12	M8	M10	M12
<b>Clay common (Dry pressed)</b> $f_{uc}^{b)} \geq 14 \text{ N/mm}^2$ L x H x B [mm] 230 x 110 x 76  Australia	80	$N_{rec}$ [kN]	-	2.5	3.0	4.0	2.5	3.0	4.0
	$V_{rec}$ [kN]	Towards free edge $c_{min} = 200$	-	2.0	2.0	2.0	2.0	2.0	2.0
		No free edges	-	3.5	5.5	7.5	3.5	5.5	7.5

a) Recommended load values with consideration of a global safety factor  $\gamma_{global} = 3.0$ :  $F_{rec} = F_{Rk} / \gamma_{global}$

b)  $f_{uc}$  = unconfined compressive strength

## Design

### Influence of joints:

If the joints of the masonry are not visible the recommended load  $N_{rec}$  has to be reduced with the factor  $\alpha_j = 0.75$ .

If the joints of the masonry are visible (e.g. unplastered wall) following has to be taken into account:

- The recommended load  $N_{rec}$  may be used only, if the wall is designed such that the joints are to be filled with mortar.
- If the wall is designed such that the joints are not to be filled with mortar then the recommended load  $N_{rec}$  may be used only, if the minimum edge distance  $c_{min}$  to the vertical joints is observed. If this minimum edge distance  $c_{min}$  can not be observed then the recommended load  $N_{rec}$  has to be reduced with the factor  $\alpha_j = 0.75$ .

**The decisive resistance to tension loads is the lower value of  $N_{rec}$  (brick breakout, pull out) and  $N_{max,pb}$  (pull out of one brick).**

### Pull out of one brick:

The allowable load of an anchor or a group of anchors in case of pull out of one brick,  $N_{max,pb}$  [kN], is given in the following tables:

### Clay bricks:

$N_{max,pb}$ [kN]		brick breadth $b_{brick}$ [mm]					
		80	120	200	240	300	360
brick length $l_{brick}$ [mm]	240	1.1	1.6	2.7	3.3	4.1	4.9
	300	1.4	2.1	3.4	4.1	5.1	6.2
	500	2.3	3.4	5.7	6.9	8.6	10.3

### All other brick types:

$N_{max,pb}$ [kN]		brick breadth $b_{brick}$ [mm]					
		80	120	200	240	300	360
brick length $l_{brick}$ [mm]	240	0.8	1.2	2.1	2.5	3.1	3.7
	300	1.0	1.5	2.6	3.1	3.9	4.6
	500	1.7	2.6	4.3	5.1	6.4	7.7

$N_{max,pb}$  = resistance for pull out of one brick

$l_{brick}$  = length of the brick

$b_{brick}$  = breadth of the brick

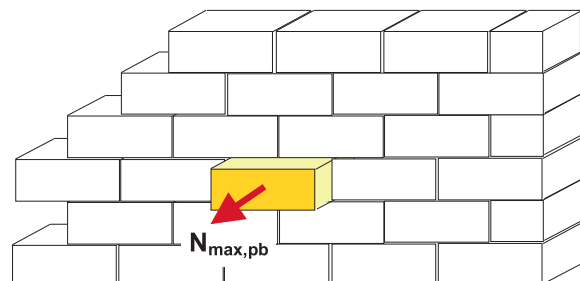
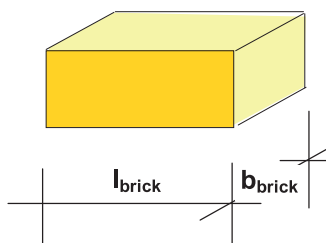

**For all applications outside of the above mentioned base materials and / or setting conditions site tests have to be made for the determination of load values.**

## Materials

### Material quality HAS

Part	Material
Threaded rod HAS-(E), HAS-(E)-(F)	Strength class 5.8, EN ISO 898-1, A5 > 8% ductile steel galvanized $\geq 5 \mu\text{m}$ , EN ISO 4042 (F) hot dipped galvanized $\geq 45 \mu\text{m}$ , EN ISO 10684
Threaded rod HAS-(E)R	Stainless steel grade A4, A5 > 8% ductile strength class 70, EN ISO 3506-1, EN 10088: 1.4401
Washer ISO 7089	Steel galvanized, EN ISO 4042;
	Stainless steel, EN 10088: 1.4401
Nut EN ISO 4032	Strength class 8, ISO 898-2 steel galvanized $\geq 5 \mu\text{m}$ , EN ISO 4042
	Strength class 70, EN ISO 3506-2, stainless steel grade A4, EN 10088: 1.4401
	Strength class 70, EN ISO 3506-2, high corrosion resistant steel, EN 10088: 1.4529; 1.4565

### Material quality HIT-A

Part	Material
HIT-AC rod	Carbon steel grade 5.8; galvanized to min. $5 \mu\text{m}$
HIT-ACR rod	Stainless steel, grade A4-70; 1.4401
HIT-AN rod	Carbon steel grade 3.6; galvanized to min. $5 \mu\text{m}$

### Material quality sleeves

Part	Material
HIT-IG sleeve	Carbon steel 1.0718; galvanized to min. $5 \mu\text{m}$
HIT-IC sleeve	Carbon steel; galvanized to min. $5 \mu\text{m}$
HIT-SC sleeve	PA/PP

## Setting

### Installation equipment

Anchor size	M6	M8	M10	M12
Rotary hammer	TE2 – TE16			
Other tools	blow out pump, set of cleaning brushes, dispenser			

## Setting instructions in solid base materials



15	°F	°C	t <sub>gel</sub>
	23	-5	10 min
	32	0	10 min
	41	5	10 min
	50	10	7 min
	68	20	4 min
	86	30	2 min
104	40	1 min	

16	°F	°C	t <sub>cure</sub>
	23	-5	6 h
	32	0	4 h
	41	5	2.5 h
	50	10	1.5 h
	68	20	45 min
	86	30	30 min
104	40	20 min	

Setting details: hole depth  $h_0$  and effective anchorage depth in solid base materials

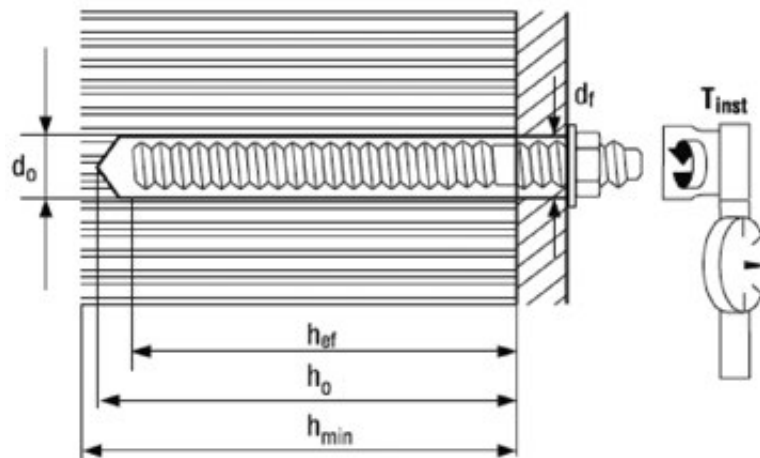

Setting details HIT-AC, HIT-V, HIT-V, HAS-E, HAS-E-F, HAS-E-R

Anchor size		HIT-AC, HIT-V			HIT-V, HAS-E, HAS-E-F, HAS-E-R <sup>c)</sup>			
		M8	M10	M12	M8	M10	M12	M16
Nominal diameter of drill bit	$d_0$ [mm]	10	12	14	10	12	14	18
Effective anchorage depth	$h_{ef}$ [mm]	80	80	80	80	90	110	125
Hole depth	$h_0$ [mm]	85	85	85	85	95	115	130
Minimum base material thickness	$h_{min}$ [mm]	110	110	110	110	120	140	170
Diameter of clearance hole in the fixture	$d_f$ [mm]	9	12	14	9	12	14	18
Minimum spacing <sup>a), b)</sup>	$s_{min}$ [mm]	100	100	100	100	100	100	100
Minimum edge distance <sup>a)</sup>	$c_{min}$ [mm]	100	100	100	100	100	100	100
Torque moment	$T_{inst}$ [Nm]	5	8	10	5	8	10	10
Filling volume	[ml]	4	5	7	4	6	10	15

a) In case of **shear loads towards a free edge:  $c_{min} = 200$  mm**

A distance from the edge of a broken brick of  $c_{min} = 200$  mm is recommended, e.g. around window or door frames.

b) Recommend to place one anchor per brick, in the middle of the brick face.

c) Refer the Recommended loads table for the required setting depth.



HIT-IG, HIT-IC

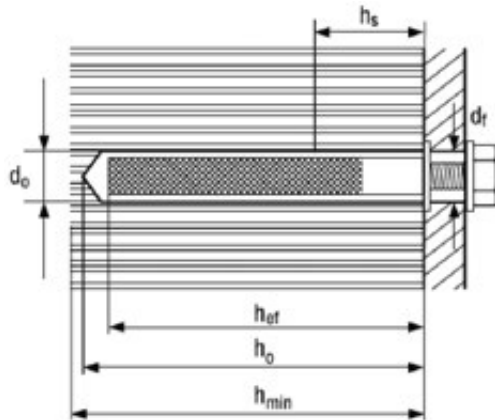

HIS-N/RN

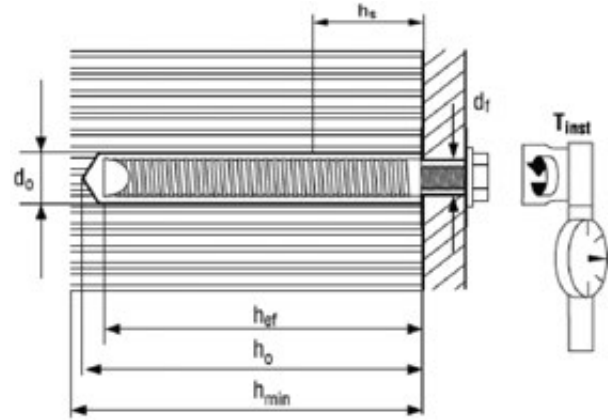

## Setting details HIT-IG, HIT-IC

Anchor size		HIT-IG			HIT-IC			HIS-N/RN <sup>c)</sup>		
		M8	M10	M12	M8	M10	M12	M8	M10	M12
Nominal diameter of drill bit	$d_o$ [mm]	14	18	18	14	16	18	14	18	22
Effective anchorage depth	$h_{ef}$ [mm]	80	80	80	80	80	80	90	110	125
Hole depth	$h_o$ [mm]	85	85	85	85	85	85	95	115	130
Minimum base material thickness	$h_{min}$ [mm]	110	110	110	110	110	110	120	150	170
Diameter of clearance hole in the fixture	$d_f$ [mm]	9	12	14	9	12	14	9	12	14
Length of bolt engagement	$h_s$ [mm]	min. 10 – max. 75			min. 10 – max. 75			min. 8 max.20	min. 10 max.25	min. 12 max.30
Minimum spacing <sup>a), b)</sup>	$s_{min}$ [mm]	100	100	100	100	100	100	100	100	100
Minimum edge distance <sup>a)</sup>	$c_{min}$ [mm]	100	100	100	100	100	100	100	100	100
Torque moment	$T_{inst}$ [Nm]	5	8	10	5	8	10	5	8	10
Filling volume	[ml]	6	6	6	6	6	6	6	10	16

a) In case of **shear loads towards a free edge:  $c_{min} = 200$  mm**

A distance from the edge of a broken brick of  $c_{min} = 200$  mm is recommended, e.g. around window or door frames.

b) Recommend to place one anchor per brick, in the middle of the brick face.

c) Refer the Recommended loads table for the required setting depth.

Setting instruction in hollow base material – using 330 ml foil pack



**11** 2x 330ml  
3x 500ml

**12** HIT-SC

**13** HIT-SC

**14** HIT-S

**15**  $t_{gel}$

**16**  $t_{cure}$

**17**  $T_{inst}$

15		°F	°C	$t_{gel}$
		23	-5	10 min
		32	0	10 min
		41	5	10 min
		50	10	7 min
		68	20	4 min
		86	30	2 min
		104	40	1 min

16		°F	°C	$t_{cure}$
		23	-5	6 h
		32	0	4 h
		41	5	2.5 h
		50	10	1.5 h
		68	20	45 min
		86	30	30 min
		104	40	20 min

## Setting details: hole depth $h_0$ and effective anchorage depth in hollow base materials HAS-E / HIT-AC with HIT-SC



### HIT-AC, HIT-V, HAS-E

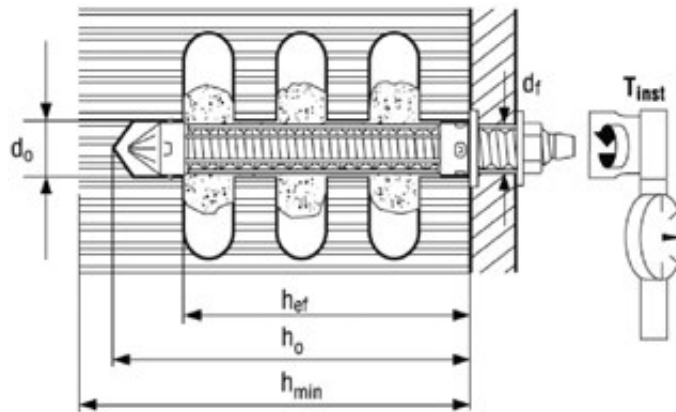

## Setting details HIT-V / HAS-E / HIT-A...with sieve sleeve

Anchor size		M6		M8		M10		M12			
Sieve sleeve HIT SC		12x50	12x85	16x50	16x85	16x50	16x85	18x50	18x85	22x50	22x85
Nominal diameter of drill bit	$d_0$ [mm]	12	12	16	16	16	16	18	18	22	22
Effective anchorage depth	$h_{ef}$ [mm]	50	80	50	80	50	80	50	80	50	80
Hole depth	$h_0$ [mm]	60	95	60	95	60	95	60	95	60	95
Minimum base material thickness	$h_{min}$ [mm]	80	110	80	110	80	110	80	110	80	110
Diameter of clearance hole in the fixture	$d_f$ [mm]	7	7	9	9	12	12	14	14	14	14
Minimum spacing <sup>a), b)</sup>	$s_{min}$ [mm]	100	100	100	100	100	100	100	100	100	100
Minimum edge distance <sup>a)</sup>	$c_{min}$ [mm]	100	100	100	100	100	100	100	100	100	100
Torque moment	$T_{inst}$ [Nm]	3	3	3	3	4	4	6	6	6	6
Filling volume	[ml]	12	24	18	30	18	30	18	36	30	55

a) In case of **shear loads towards a free edge:  $c_{min} = 200$  mm**

A distance from the edge of a broken brick of  $c_{min} = 200$  mm is recommended, e.g. around window or door frames.

b) Recommended one anchor per brick in the middle of the brick face. In the case of hollow concrete blocks one anchor per cavity in the middle of each cavity face.



## Setting details: hole depth $h_0$ and effective anchorage depth in hollow base materials

HIT-IG / HIT-IC with HIT-SC



### HIT-IG / HIT-IC

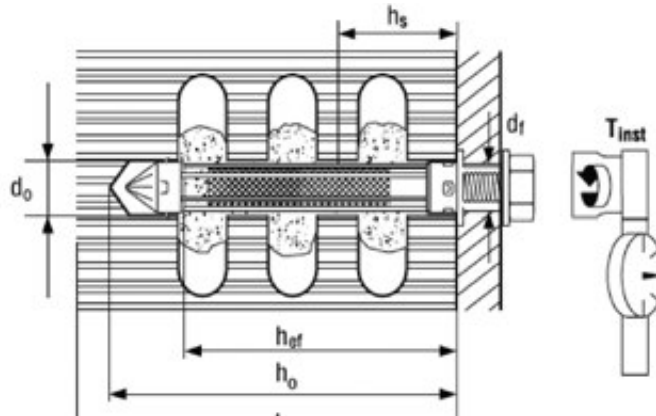

### Setting details HIT-IG / HIT-IC with sieve sleeve

Anchor size		HIT-IG			HIT-IC		
		M8	M10	M12	M8	M10	M12
Sieve sleeve HIT SC		16x85	22x85	22x85	16x85	18x85	22x85
Nominal diameter of drill bit	$d_0$ [mm]	16	22	22	16	18	22
Effective anchorage depth	$h_{ef}$ [mm]	80	80	80	80	80	80
Hole depth	$h_0$ [mm]	95	95	95	95	95	95
Minimum base material thickness	$h_{min}$ [mm]	110	110	110	110	110	110
Diameter of clearance hole in the fixture	$d_f$ [mm]	9	12	14	9	12	14
Length of bolt engagement	$h_s$ [mm]	min. 10 – max. 75			min. 10 – max. 75		
Minimum spacing <sup>a), b)</sup>	$s_{min}$ [mm]	100	100	100	100	100	100
Minimum edge distance <sup>a)</sup>	$c_{min}$ [mm]	100	100	100	100	100	100
Torque moment	$T_{inst}$ [Nm]	3	4	6	3	4	6
Filling volume	[ml]	30	45	45	30	36	45

a) In case of **shear loads towards a free edge**:  $c_{min} = 200$  mm

A distance from the edge of a broken brick of  $c_{min} = 200$  mm is recommended, e.g. around window or door frames.

b) Recommended one anchor per brick in the middle of the brick face. In the case of hollow concrete blocks one anchor per cavity in the middle of each cavity face.

## Chemical anchor components & accessories

### 1. Dispensing Systems

#### Manual Dispenser: HDM 330 / 500



HDM 330 / 500  
dispenser

#### Benefits

- Hard plastic, light weight
- 330ml or 500ml tubes
- Can achieve embedment up to 1.0m deep dependant on hole diameter

#### Battery Dispenser: HDE-500-A2



HDE-500-A2  
dispenser

#### Benefits

- Hard plastic, light weight.
- Lithium Ion batteries
- Dosing knob for accurate borehole filling
- Can achieve embedments up to 1.8m deep dependant on hole diameter

#### Pneumatic Dispenser: HIT P-8000D



HIT P-8000D  
pneumatic dispenser

#### Benefits

- Ideal for repetitive / deep embedment holes.
- 1400ml tubes, large volume capacity
- Dosage control
- Can achieve embedments up to 3.2m deep dependant on hole diameter
- Requires air compressor

## 2. Piston Plug & Cleaning Accessories

Piston Plug

Extension Hose



Piston Plug + Extension Hose + Cleaning + Dispenser + HIT Injection Mortar = SOLUTION

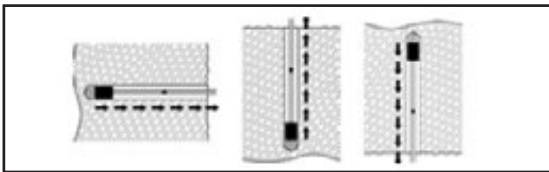

Inject mortar carefully from the bottom of the hole  
without air bubbles

Hole dia. (mm)	HAS-E or HIT-V (mm)	HIS-N (mm)	Rebar (mm)	HIT-SZ Piston Plug		HIT-RB Cleaning Brush	
					Item No.		Item No.
10	8			-	-	10	380917
12	10		8	8/12	335022	8/12	336548
14	12	8	10	10/14	335023	10/14	336549
16			12	12/16	335024	12/16	336550
18	16	10		14/18	335025	14/18	336551
20			16	16/20	335026	16/20	336552
22		12		-	-	18/22	370774
24	20			-	-	24	380918
25			20	20/25	335027	20/25	336553
28	24	16		-	-	28	380919
30				30	380925	30	380920
32		20	24	25/32	335028	25/32	336554
35	30		28	35	380926	35	380921
37			30	-	-	37	382259
40	36			40	380927	40	382260
42			32	42	380928	42	382261
45	39		36	45	380929	45	382262
47				47	380930	-	-
52			40	-	-	-	-

## 3. Overhead accessories for HIT chemical injection

Wedge HIT-OHW

Drip Guard HIT-OHC



387550	Wedge HIT-OHW
387551	Drip Guard HIT-OHC1
387552	Drip Guard HIT OHC2

#### 4. Threaded Anchor Rods and Internally Threaded Sleeves

### HIT-V threaded anchor rod

A universal anchor rod for use with all HIT injectable mortars, enabling flexible embedment depth.



HIT-HY 150 MAX ETA-08/0352  
HIT-RE 500 ETA-04/0027  
HIT-RE 500-SD ETA-07/0260

CE  
conformity

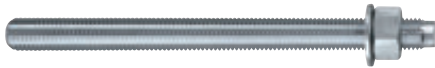

#### HIT-V threaded anchor rod

A universal anchor rod for use with all HIT injectable mortars, enabling flexible embedment depth. Zinc plated version (complete with nut and washer), 5.8 grade steel.

#### HIT-VR threaded anchor rod

A universal anchor rod for use with all HIT injectable mortars, enabling flexible embedment depth. Stainless steel version (complete with nut and washer), A4-70 grade steel.

Max. fastenable height + anchorage depth	Typical embedment depth (mm)	Rod length (mm)	Drill bit dia. (mm)	Package contents (pcs)	Ordering designation	Item no.
65	80	80	10	20	HIT-V M8 × 80	<b>387054</b>
95	80	110	10	20	HIT-V M8 × 110	<b>387055</b>
135	80	150	10	20	HIT-V M8 × 150**	<b>387056</b>
78	90	95	12	10	HIT-V M10 × 95	<b>387057</b>
98	90	115	12	10	HIT-V M10 × 115	<b>387146</b>
113	90	130	12	10	HIT-V M10 × 130	<b>387058</b>
173	90	190	12	10	HIT-V M10 × 190**	<b>387059</b>
91	110	110	14	10	HIT-V M12 × 110	<b>387060</b>
101	110	120	14	10	HIT-V M12 × 120	<b>387147</b>
131	110	150	14	10	HIT-V M12 × 150	<b>387061</b>
201	110	220	14	10	HIT-V M12 × 220**	<b>387062</b>
261	110	280	14	10	HIT-V M12 × 280**	<b>387063</b>
127	125	150	18	5	HIT-V M16 × 150	<b>387064</b>
177	125	200	18	5	HIT-V M16 × 200	<b>387065</b>
277	125	300	18	5	HIT-V M16 × 300	<b>387066</b>
357	125	380	18	5	HIT-V M16 × 380**	<b>387067</b>
153	170	180	24	10	HIT-V M20 × 180	<b>387068</b>
233	170	260	24	10	HIT-V M20 × 260	<b>387069</b>
353	170	380	24	10	HIT-V M20 × 380	<b>387070</b>
453	170	480	24	10	HIT-V M20 × 480	<b>387071</b>
268	210	300	28	5	HIT-V M24 × 300	<b>387072</b>
418	210	450	28	5	HIT-V M24 × 450	<b>387073</b>

\* Depending on the type of HIT injectable mortar used

\*\* 8.8 grade steel

Max. fastenable height + anchorage depth	Typical embedment depth (mm)	Rod length (mm)	Drill bit dia. (mm)	Package contents (pcs)	Ordering designation	Item no.
65	80	80	10	20	HIT-V-R M8 × 80	<b>387074</b>
95	80	110	10	20	HIT-V-R M8 × 110	<b>387075</b>
135	80	150	10	20	HIT-V-R M8 × 150	<b>387076</b>
78	90	95	12	10	HIT-V-R M10 × 95	<b>387077</b>
98	90	115	12	10	HIT-V-R M10 × 115	<b>387148</b>
113	90	130	12	10	HIT-V-R M10 × 130	<b>387078</b>
173	90	190	12	10	HIT-V-R M10 × 190	<b>387079</b>
91	110	110	14	10	HIT-V-R M12 × 110	<b>387080</b>
101	110	120	14	10	HIT-V-R M12 × 120	<b>387149</b>
131	110	150	14	10	HIT-V-R M12 × 150	<b>387081</b>
201	110	220	14	10	HIT-V-R M12 × 220	<b>387082</b>
261	110	280	14	10	HIT-V-R M12 × 280	<b>387083</b>
127	125	150	18	5	HIT-V-R M16 × 150	<b>387084</b>
177	125	200	18	5	HIT-V-R M16 × 200	<b>387085</b>
277	125	300	18	5	HIT-V-R M16 × 300	<b>387086</b>
357	125	380	18	5	HIT-V-R M16 × 380	<b>387087</b>
153	170	180	24	10	HIT-V-R M20 × 180	<b>387150</b>
233	170	260	24	10	HIT-V-R M20 × 260	<b>387088</b>
353	170	380	24	10	HIT-V-R M20 × 380	<b>387089</b>
453	170	480	24	10	HIT-V-R M20 × 480	<b>387151</b>
268	210	300	28	5	HIT-V-R M24 × 300	<b>387152</b>
418	210	450	28	5	HIT-V-R M24 × 450	<b>387153</b>

#### HIT-V-F threaded anchor rod

Universal anchor rod for use with all HIT injectable mortars, enabling flexible embedment depth.

Hot dip-galvanized version (complete with nut and washer), 5.8 grade steel.

Available in same sizes and steel strength grade as HIT-V (zinc plated).

### HAS-E anchor rod, complete with hexagon nut & washer

External end drive for quicker installation.



With external end drive

Item no.	Ordering designation	Anchor length	Hole dia.	Hole depth	Max Fasten. Thickness	Tighten Torque (Nm)	Package contents
<b>Steel (Grade 5.8, <math>f_{uk} = 500</math> MPa) zinc plated to min. 5 microns</b>							
332219	HAS-E M8 x 80/14	106mm	10mm	80mm	14mm	15	20
332220	HAS-E M10 x 90/21	125mm	12mm	90mm	21mm	30	20
332221	HAS-E M12 x 110/28	153mm	14mm	110mm	28mm	50	20
332222	HAS-E M16 x 125/38	182mm	18mm	125mm	38mm	100	20
332223	HAS-E M20 x 170/48	240mm	24mm	170mm	48mm	160	10
332224	HAS-E M24 x 210/54	290mm	28mm	210mm	54mm	240	10
<b>Steel (Grade 5.8, <math>f_{uk} = 500</math> MPa) hot dipped galvanised to min. 40 microns</b>							
333143	HAS-E-F M8 x 80/14	106mm	10mm	80mm	14mm	15	20
333145	HAS-E-F M10 x 90/21	125mm	12mm	90mm	21mm	30	20
333148	HAS-E-F M12 x 110/28	153mm	14mm	110mm	28mm	50	20
333153	HAS-E-F M16 x 125/38	182mm	18mm	125mm	38mm	100	20
333158	HAS-E-F M20 x 170/48	240mm	24mm	170mm	48mm	160	10
333163	HAS-E-F M24 x 210/54	290mm	28mm	210mm	54mm	240	10
333165▲	HAS-E-F M30 x 270/70 (grade 8.8)	380mm	35mm	270mm	70mm	300	4
333167▲	HAS-E-F M36 x 330/90 (grade 8.8)	460mm	40mm	330mm	90mm	360	2
<b>Stainless steel (316 grade, <math>f_{uk} = 700</math> MPa)</b>							
333119	HAS-E-R M8 x 80/14	106mm	10mm	80mm	14mm	15	20
333122	HAS-E-R M10 x 90/21	125mm	12mm	90mm	21mm	30	20
333126	HAS-E-R M12 x 110/28	153mm	14mm	110mm	28mm	50	20
333131	HAS-E-R M16 x 125/38	182mm	18mm	125mm	38mm	100	20
333135	HAS-E-R M20 x 170/48	240mm	24mm	170mm	48mm	160	10
333137	HAS-E-R M24 x 210/54	290mm	28mm	210mm	54mm	240	10

▲ Other sizes available on request and subject to lead time

### HIS-N internally threaded sleeve with cover cap



Item no.	Ordering designation	Hole dia.	Hole depth	Max Fasten. Thickness	Tighten Torque (Nm)	Package contents
<b>Steel (<math>f_{uk} = 460 - 490</math> MPa) zinc plated to min. 5 microns</b>						
258015	HIS-N M8 x 90 (for HVU M10)	14mm	95mm	20mm	15	10
258016	HIS-N M10 x 110 (For HVU M12)	18mm	115mm	25mm	28	10
258017	HIS-N M12 x 125 (For HVU M16)	22mm	130mm	30mm	50	5
258018	HIS-N M16 x 170 (For HVU M20)	28mm	175mm	40mm	85	5
258019	HIS-N M20 x 205 (For HVU M24)	32mm	210mm	50mm	170	5
<b>Stainless steel (316 grade, <math>f_{uk} = 700</math> MPa)</b>						
258024	HIS-RN M8 x 90 (HVU M10)	14mm	95mm	20mm	12	10
258025	HIS-RN M10 x 110 (HVU M12)	18mm	115mm	25mm	23	10
258026	HIS-RN M12 x 125 (HVU M16)	22mm	130mm	30mm	40	5
258027	HIS-RN M16 x 170 (HVU M20)	28mm	175mm	40mm	70	5
258028	HIS-RN M20 x 205 (HVU M24)	32mm	210mm	50mm	130	5