

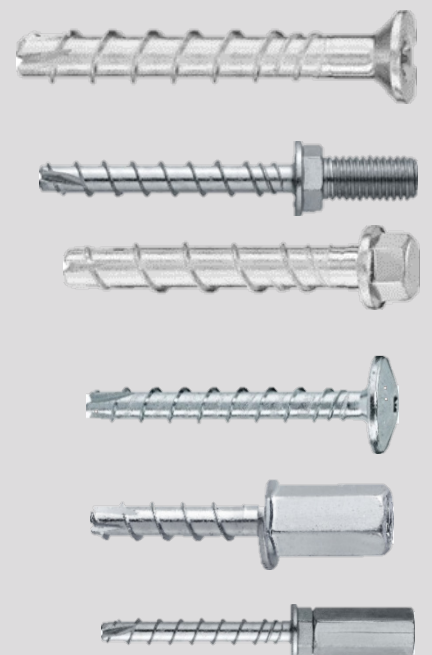

PRODUCT TECHNICAL DATASHEET

HUS3, HUS4 Screw anchor

Redundant fastening
Update: Mar-26



Steel-to-concrete Page no: 04

Hollow core slab Page no: 14

HUS4, HUS3, Screw anchor

Anchor version



HUS3-H (6)



HUS4-HR (6)



HUS3-C (6)



HUS4-CR (6)



HUS3-A (6)



HUS3-PL (6)



HUS3-P (6)



HUS3-PS (6)

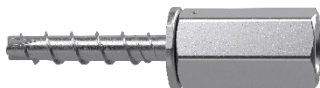

HUS3-IQ (6)



HUS3-I (6)



HUS3-I Flex (6)



HUS3-IF Flex (6)



Linked to Instruction for use (IFU) and Hilti webpage

Anchor size	6				
HUS3	H	I	IQ	I(F) Flex	A
	IFU HUS3-H	IFU HUS3-I	IFU HUS3-IQ	IFU HUS3-I (F) Flex	IFU HUS3-A
HUS3	C	P	PL	PS	
	IFU HUS3-C	IFU HUS3-P	IFU HUS3-PL	IFU HUS3-PS	
HUS4	HR	CR			
	IFU HUS4-HR	IFU HUS4-CR	-		

The instructions for use can be viewed using the link in the instructions for use table or the QR code/link in the Hilti webpage table.

Link to Hilti Webpage

HUS3-H	HUS3-I	HUS3-IQ	HUS3-I Flex	HUS3-IF Flex	HUS3-A	HUS3-C
						
HUS3-P	HUS3-PL	HUS3-PS	HUS4-HR	HUS4-CR		
						



PRODUCT TECHNICAL DATASHEET

HUS3, HUS4 Screw anchor



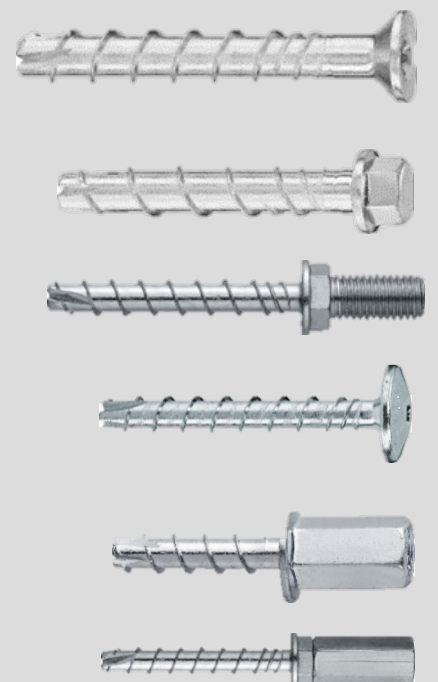









Steel-to-concrete
Redundant fastening





HUS4, HUS3, Screw anchor for use in concrete

High performance screw anchor for redundant fastening applications

Anchor version		Benefits
	HUS3-H (6)	<ul style="list-style-type: none">- Quick and easy setting- Low expansion forces in base materials- Removable- Forged-on washer and hexagon head with no protruding thread- ETA approval for cracked and uncracked concrete- High productivity – less drilling and fewer operations than with conventional anchors- Through-fastening and pre-setting (based on the head configuration)- HUS3-IF Flex with multilayer coatings for additional corrosion protection
	HUS4-HR (6)	
	HUS3-C (6)	
	HUS4-CR (6)	
	HUS3-A (6)	
	HUS3-PL (6)	
	HUS3-P (6)	
	HUS3-PS (6)	
	HUS3-IQ (6)	
	HUS3-I (6)	
	HUS3-I Flex (6)	
	HUS3-IF Flex (6)	
	HUS3-IF Flex (6)	



Base material

Concrete (uncracked)

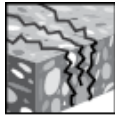

Concrete (cracked)

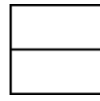
Load conditions

Static / quasi-static



Fire Resistance

Drilling, cleaning, setting

Hammer drilled holes

Other information

[Steel to concrete connection Handbook](#)
Linked Approvals/Certificates
Approvals/certificates

Approval no	Application / loading condition	Authority / Laboratory	Date of issue
ETA-10/0005	Static and quasi-static / Fire	DIBt, Berlin	15-09-2025

Redundant fastening
Requirements for redundant fastening

The definition of redundant fastening is given in EN 1992-4 and CEN/TR 17079. In Absence of a definition by a Member State the following parameters must be considered.

Minimum number of fixing points	Minimum number of anchors per fixing point	Maximum design load of action F_{Sd} per fixing point
3	1	2 kN
4	1	3 kN

The value for maximum design load of actions per fastening point F_{Sd} is valid in general that means all fastening points are considered in the design of the redundant structural system. F_{Sd} can be a tension, shear or inclined load.

Fastener special dimensions

Anchor dimensions

Type		HUS4	HUS3								
		HR, CR	H	C	A	PL	P	PS	I	I(F) Flex	IQ
Diameter			6								
Nominal length	L [mm]	35-70	40-120	40-70	35-55	60	40-80	40-60	35-55	35-55	35
Threaded outer diameter	d_t [mm]	7,6	7,85								
Shaft diameter	d_s [mm]	5,8	6,15								
Diameter of integrated washer	d_i [mm]	-	16,5	-	-	-	-	-	-	-	-

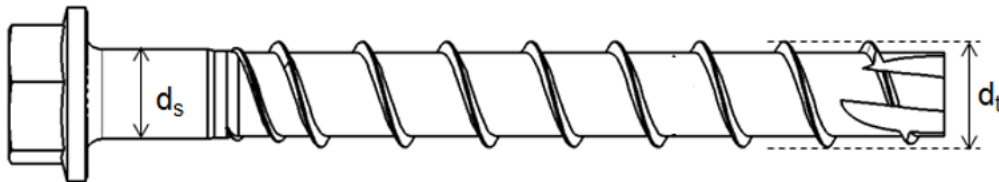

HUS3-H

Type		HUS3	HUS4	HUS3		
		C	CR	PL	P	PS
Diameter		6				
Countersunk height	h_c [mm]	4,0	4,3	-	-	-
Diameter of the countersunk	d_c [mm]	11,5	11,5	-	-	-
Pan head diameter	d_p [mm]	-	-	21,8	17,6	13,3

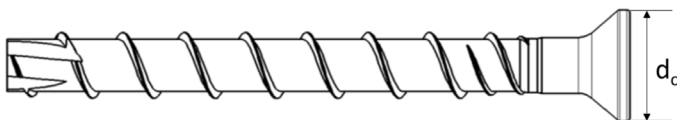

HUS3-C

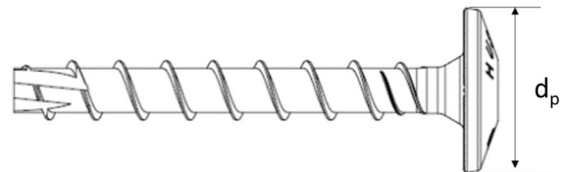

HUS3-PL, HUS3-P, HUS3-PS

Head configuration

Type	Head		
HUS3-H 6	Hexagonal head		
HUS4-HR 6	Hexagonal head		
HUS3-C 6	Countersunk head		
HUS4-CR 6	Countersunk head		
HUS3-A 6	External thread		
HUS3-PL 6	Pan head (large)		
HUS3-P 6	Pan head		
HUS3-PS 6	Pan head (small)		
HUS3-I 6	Internal thread		
HUS3-I(F) Flex 6	Internal thread		
HUS3-IQ 6	Coupler with spring		



Screw length and maximum thickness of fixture

Type		HUS4,		HUS3								
		HR	CR	H	C	A	P	PS	PL	I	I(F) Flex	IQ
Fastener size		6										
Nominal embedment depth [mm]		h_{nom} 35										
		Maximum thickness of fixture [mm] t_{fix}										
Length of Screw [mm]	35	0	-	-	-	0	-	-	-	0	0	0
	40	-	5	5	5	-	5	5	-	-	-	-
	45	10	-	-	-	-	-	-	-	-	-	-
	55	-	-	-	-	20	-	-	-	20	20	-
	60	25	25	25	25	-	25	25	25	-	-	-
	70	35	35	-	35	-	-	-	-	-	-	-
	80	-	-	45	-	-	45	-	-	-	-	-
	100	-	-	65	-	-	-	-	-	-	-	-
	120	-	-	85	-	-	-	-	-	-	-	-
	135	-	-	-	-	-	-	-	-	-	100	-
	155	-	-	-	-	-	-	-	-	-	120	-
	175	-	-	-	-	-	-	-	-	-	140	-
195	-	-	-	-	-	-	-	-	-	160	-	

Static and quasi-static loading based on ETA-10/0005. Design according to EN 1992-4 (method B)

All data in this section applies to:

- Correct setting (see Instructions for use (IFU))
- For a single anchor
- No edge distance and spacing influence (see table with characteristic distances)
- Characteristic spacing and edge distance for splitting failure apply only for uncracked concrete
- For cracked concrete only the characteristic spacing and edge distance for concrete cone failure are decisive
- Minimum base material thickness (see setting detail tables)
- Embedment depth, as specified in the table of this section
- Anchor material, as specified in the tables of this section
- Concrete C20/25
- Hammer drilled holes
- Design resistance is valid for all load directions and valid for both cracked and uncracked concrete
- Recommended loads: With overall partial safety factor for action $\gamma = 1,4$

Design resistance

Type		HUS4		HUS3	
		HR, CR		H, PL, P, PS, I, I(F) Flex, IQ, A, C	
Fastener size		6x40, 6x45, 6x60, 6x70		6 all lengths	
Nominal embedment depth	h_{nom} [mm]	35		35	
$35 \text{ mm} \leq c < 80 \text{ mm}$	F^0_{Rd} [kN]	1,4		1,3	
$c > 80 \text{ mm}$	F^0_{Rd} [kN]	1,7		2,0	

Recommended load

Type		HUS4		HUS3	
		HR, CR		H, PL, P, PS, I, I(F) Flex, IQ, A, C	
Fastener size		6x40, 6x45, 6x60, 6x70		6 all lengths	
Nominal embedment depth	h_{nom} [mm]	35		35	
$35 \text{ mm} \leq c < 80 \text{ mm}$	F^0_{rec} [kN]	1,0		0,9	
$c > 80 \text{ mm}$	F^0_{rec} [kN]	1,2		1,4	

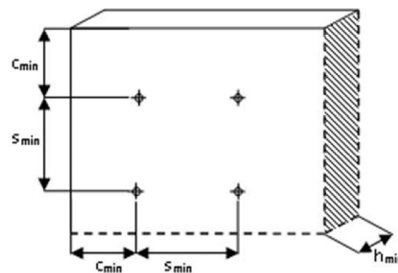

Fire resistance based on ETA-10/0005. Design according to EN 1992-4, method B

All data in this section applies to:

- Correct setting (See setting instruction)
- For a single anchor
- No edge distance and spacing influence (see table with characteristic distances)
- Characteristic spacing and edge distance for splitting failure apply only for uncracked concrete.
- For cracked concrete only the characteristic spacing and edge distance for concrete cone failure are decisive
- Minimum base material thickness (see table)
- Embedment depth, as specified in the table of this section
- Anchor material, as specified in the tables of this section
- Concrete C20/25
- Hammer drilled holes
- Design resistance is valid for all load directions and valid for both cracked and uncracked concrete
- Partial safety factor for resistance under fire exposure $\gamma_{M,fi} = 1,0$ (in absence of other national recommendations)

Design resistance

Type	HUS4		HUS3	
	HR	CR	H, P, PS, PL, I, I(F) Flex, A, C, IQ	
Fastener size	6 all lengths			
Nominal embedment depth h_{nom} [mm]	35			
Fire exposure R30, R60, R90				
All load directions $F_{Rd,fi}$ [kN]	0,7	0,2	0,5	
Fire exposure R120				
All load directions $F_{Rd,fi}$ [kN]	0,5	0,1	0,4	

Setting information

Setting details

Type	HUS4		HUS3										
	HR	CR	H	C	A	P	PL	PS	I	I(F) Flex	IQ		
Fastener size			6 all lengths										
Nominal diameter of drill bit	d_0	[mm]	6										
Maximum diameter of clearance hole in the fixture	d_f	[mm]	9										
Wrench size	SW	[mm]	13	-	13	-	13	-	-	-	13	13	17
Countersunk diameter	d_h	[mm]	-	11,0	-	11,5	-	-	-	-	-	-	-
Torx size	TX	[-]	-	T30	T30	T30	-	T30	T30	T30	-	-	-
Installation torque	T_{inst}	[mm]	machine setting only		18								
Depth of drill hole in floor/wall position	h_1	[mm]	45										
Depth of drill hole in ceiling position	h_1	[mm]	38										
Minimum base material thickness	h	[mm]	80										
Minimum distances ^{a)}													
Spacing	s_{min}	[mm]	35										
Edge distance	c_{min}	[mm]	35										
Characteristic distances													
Spacing	s_{cr}	[mm]	$3 \cdot h_{ef}$										
Edge distance	c_{cr}	[mm]	$1,5 \cdot h_{ef}$										

^{a)} For spacing (edge distance) smaller than characteristic spacing (characteristic edge distance) the design loads have to be reduced (see system design resistance).

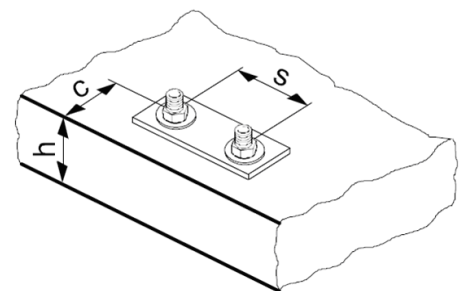



Drilling and Installation equipment

For detailed setting information on installation ,see instructions for use given with the product.

Rotary Hammers (Corded and Cordless)		TE 2 - TE 30
Other tools		Impact wrench- SIW (use recommended socket/driver bit)
		Hammer drill bit TE-CX, TE-C
		Blow out pump



PRODUCT TECHNICAL DATASHEET

HUS3, HUS4 Screw anchor



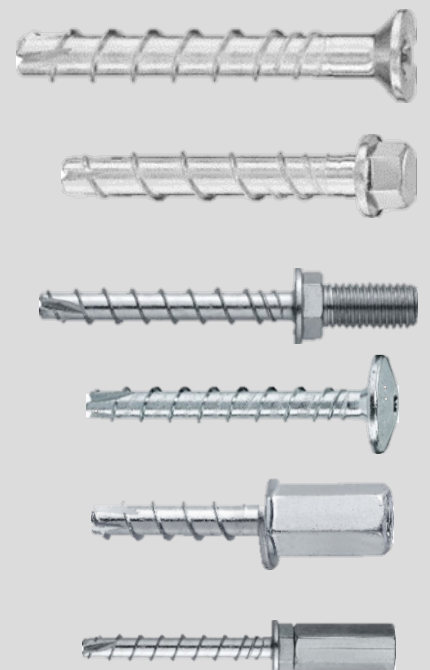









Hollow core slabs
Redundant fastening





HUS4, HUS3 Screw anchor for use in Hollow core slabs

High performance screw anchor for redundant fastening applications

Anchor version		Benefits
	HUS3-H(6)	<ul style="list-style-type: none">- Quick and easy setting- Low expansion forces in base materials- Removable- Forged-on washer and hexagon head with no protruding thread- ETA approval for hollow core slabs- High productivity – less drilling and fewer operations than with conventional anchors- Through-fastening and pre-setting (based on the head configuration),
	HUS4-HR (6)	
	HUS3-C (6)	
	HUS4-CR (6)	
	HUS3-A (6)	
	HUS3-PL (6)	
	HUS3-P (6)	
	HUS3-PS (6)	
	HUS3-IQ (6)	
	HUS3-I (6)	
	HUS3-I Flex (6)	
	HUS3-IF Flex (6)	

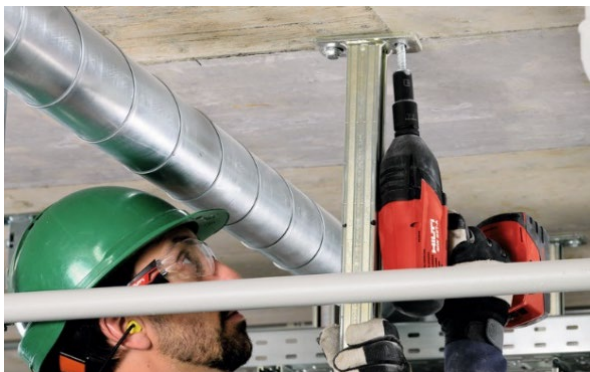

Base material
Load conditions

Prestressed hollow core slabs

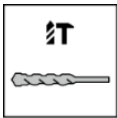

Static / quasi-static

Drilling, cleaning, setting

Hammer drilled holes

Linked Approvals/Certificates and Instructions for use
Approvals/certificates

Approval no	Application / loading condition	Authority / Laboratory	Date of issue
ETA-10/0005	Static and quasi-static / Fire	DIBt, Berlin	15-09-2025

Redundant fastening
Requirements for redundant fastening

The definition of redundant fastening is given in EN 1992-4 and CEN/TR 17079. In Absence of a definition by a Member State the following parameters must be considered.

Minimum number of fixing points	Minimum number of anchors per fixing point	Maximum design load of action F_{sd} per fixing point
3	1	2 kN
4	1	3 kN

The value for maximum design load of actions per fastening point F_{sd} is valid in general that means all fastening points are considered in the design of the redundant structural system. F_{sd} can be a tension, shear or inclined load.



Screw length and thickness of fixture used

Screw length and thickness of fixture used in precast pre-stressed hollow core slabs for size 6

Type		HUS4,		HUS3								
		HR	CR	H	C	A	P	PS	PL	I	I(F) Flex	IQ
Fastener size		6										
		Thickness of fixture [mm] t_{fix}										
Length of screw [mm]	35	0	-	-	-	0	-	-	-	0	0	0
	40	-	10	5	5	-	5	5	-	-	-	-
	45	15	-	-	-	-	-	-	-	-	-	-
	55	-	-	-	-	20	-	-	-	20	20	-
	60	5-25	5-25	5-25	5-25	-	5-25	5-25	5-25	-	-	-
	70	15-35	15-35	-	15-35	-	-	-	-	-	-	-
	80	-	-	25-45	-	-	25-45	-	-	-	-	-
	100	-	-	45-65	-	-	-	-	-	-	-	-
	120	-	-	65-85	-	-	-	-	-	-	-	-
	135	-	-	-	-	-	-	-	-	-	80-100	-
	155	-	-	-	-	-	-	-	-	-	100-120	-
	175	-	-	-	-	-	-	-	-	-	120-140	-
	195	-	-	-	-	-	-	-	-	-	140-160	-

Basic loading data for redundant fastening in prestressed hollow core slabs based on ETA-10/0005 and Design according to EN 1992-4 (method B)

All data in this section applies to:

- Correct setting (See setting instruction)
- For a single anchor
- No edge distance and spacing influence (provided $c \geq c_{min}$ and $s \geq s_{min}$)
- Embedment depth, as specified in the table of this section
- Anchor material, as specified in the tables of this section
- Concrete C 30/37 to C50/56
- Hammer drilled holes
- Design resistance is valid for all load directions and valid for both cracked and uncracked concrete
- Recommended loads: With overall partial safety factor for action $\gamma = 1,4$.

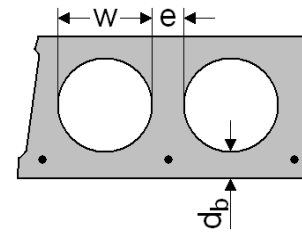

Design resistance

Type	HUS4 HR, CR						HUS3 H, PL, P, PS, I, I(F) Flex, IQ, A, C			
	6x40, 6x45		6x60, 6x70				6 all lengths			
	Minimum Bottom flange thickness	d_b	[mm]	25	30	25	30	35	25	30
All load directions	F_{Rd}	[kN]	0,7	1,3	0,7	1,3	2,0	0,7	1,3	2,0

Recommended load

Type	HUS4 HR, CR						HUS3 H, PL, P, PS, I, I(F) Flex, IQ, A, C			
	6x40, 6x45		6x60, 6x70				6 all lengths			
	Minimum Bottom flange thickness	d_b	[mm]	25	30	25	30	35	25	30
All load directions	F_{rec}	[kN]	0,5	1,0	0,5	1,0	1,4	0,5	1,0	1,4

Setting information

Setting details

Type	HUS4		HUS3	
	HR	CR	H, PL, P, PS, I, I(F) Flex, IQ, A, C	
Anchor size	6			
Effective anchorage depth	h_{ef}	[mm]	25	
Bottom flange thickness	$d_{b,min}$	[mm]	25	
Nominal diameter of drill bit	d_0	[mm]	6	
Nominal depth of drill hole	h_{1min}	[mm]	38	
Clearance hole diameter	d_f	[mm]	9	
Distance between anchor and prestressing steel	$a_{p,min}$	[mm]	50	
Core distance	$l_{c,min}$	[mm]	100	
Pre-stressing steel distance	l_{pmin}	[mm]	100	
Installation torque	T_{inst}	[mm]	(machine setting only)	18

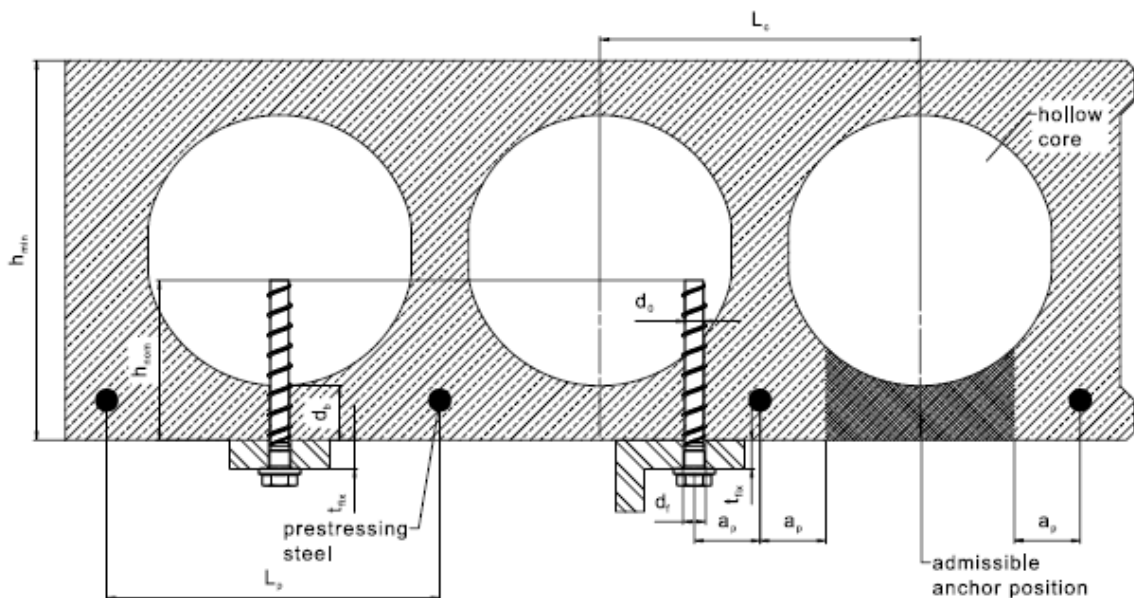

Anchor spacing and edge distance

Type			HUS4-HR, CR HUS3-H, PL,P, PS, I, I(F) Flex, IQ, A, C
Minimum edge distance	c_{min}	[mm]	100
Minimum anchor spacing	s_{min}	[mm]	100
Minimum distance between anchor groups	a_{min}	[mm]	100

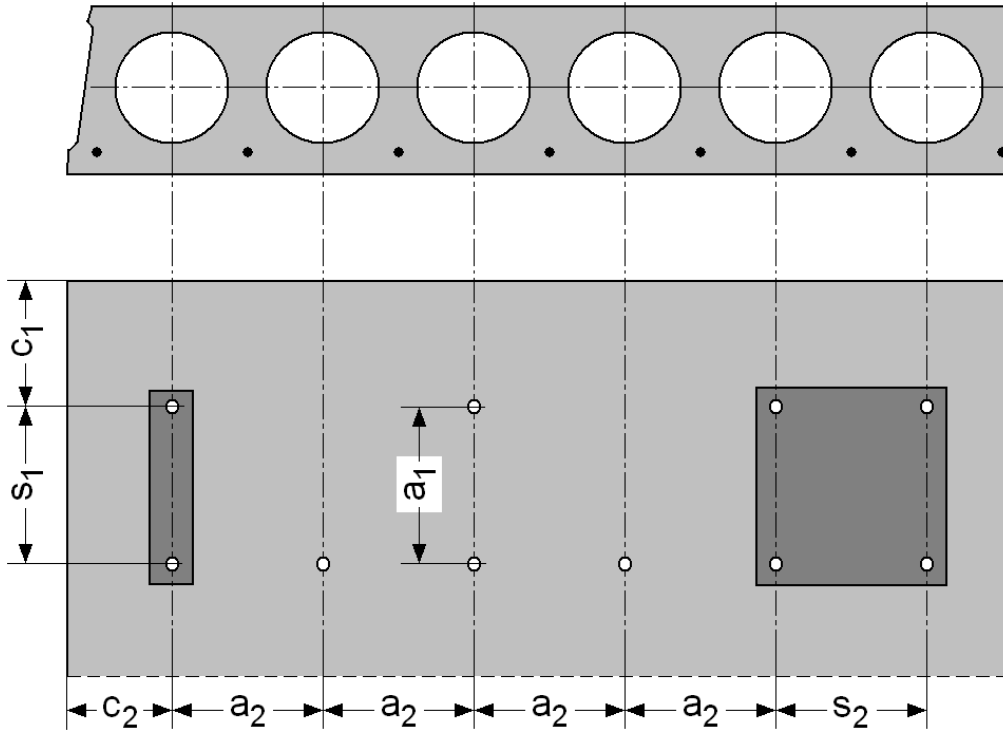

c_1, c_2 edge distance
 s_1, s_2 Anchor spacing
 a_1, a_2 Distances between anchor groups



Drilling and Installation equipment

For detailed setting information on installation ,see instructions for use given with the product.

Rotary Hammers (Corded and Cordless)		TE 2 - TE 30
Other tools		Impact wrench- SIW (use recommended socket/driver bit)
		Hammer drill bit TE-CX, TE-C
		Blow out pump